

## Features

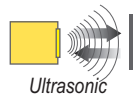

- Fast, easy-to-use TEACH-Mode programming; no potentiometer adjustments
- Ultra-compact housing
- One discrete output: NPN or PNP, depending on model
- Two bi-colored status LEDs
- Rugged encapsulated version for harsh environments
- Choose 2 meter or 9 meter unterminated cable, 4-pin Euro-style or 4-pin Pico-style QD connectors (either integral or with 150 mm pigtail)
- Wide operating range of -20° to +60° C (-13° to +140° F)
- Temperature compensation
- Configurable for normally open or normally closed operation
- Fast response time (15 milliseconds)



## Models

Model	Sensing Range	TEACH Options	Cable*	Supply Voltage	Output
QS18UNA	50 mm to 500 mm (2" to 20")	Integral push button or remote TEACH (IP67, NEMA 6P)	4-wire, 2 m (6.5') cable with shield	12-30V dc	NPN
QS18UPA					PNP
QS18UNAE		Remote TEACH (epoxy-encapsulated, IP68, NEMA 6P)			NPN
QS18UPAE					PNP

\*Only standard 2 m (6.5') cable models are listed. For 9 m (30') shielded cable, add suffix "W/30" to the model number (e.g., **QS18UNA W/30**).

### QD models:

- For 4-pin integral Euro-style QD, add suffix "Q8" (e.g., **QS18UNAQ8**).
  - For 4-pin Euro-style 150 mm (6") pigtail QD, add suffix "Q5" (e.g., **QS18UNAQ5**).
  - For 4-pin integral Pico-style QD, add suffix "Q7" (e.g., **QS18UNAQ7**).
  - For 4-pin Pico-style 150 mm (6") pigtail QD, add suffix "Q" (e.g., **QS18UNAQ**).
- A model with a QD connector requires a mating cordset (see page 10).

### **⚠ WARNING . . . Not To Be Used for Personnel Protection**

**Never use these products as sensing devices for personnel protection. Doing so could lead to serious injury or death.**

These sensors do NOT include the self-checking redundant circuitry necessary to allow their use in personnel safety applications. A sensor failure or malfunction can cause either an energized or de-energized sensor output condition. Consult your current Banner Safety Products catalog for safety products which meet OSHA, ANSI and IEC standards for personnel protection.

## Principles of Operation

Ultrasonic sensors emit one or multiple pulses of ultrasonic energy, which travel through the air at the speed of sound. A portion of this energy reflects off the target and travels back to the sensor. The sensor measures the total time required for the energy to reach the target and return to the sensor. The distance to the object is then calculated using the following formula:

$$D = \frac{ct}{2}$$

**D** = distance from the sensor to the target  
**c** = speed of sound in air  
**t** = transit time for the ultrasonic pulse

To improve accuracy, an ultrasonic sensor may average the results of several pulses before outputting a new value.

### Temperature Effects

The speed of sound is dependent upon the composition, pressure and temperature of the gas in which it is traveling. For most ultrasonic applications, the composition and pressure of the gas are relatively fixed, while the temperature may fluctuate.

In air, the speed of sound varies with temperature according to the following approximation:

$$C_{m/s} = 20 \sqrt{273 + T_c}$$

**C<sub>m/s</sub>** = speed of sound in meters per second  
**T<sub>c</sub>** = temperature in °C

Or, in English units:

$$C_{ft/s} = 49 \sqrt{460 + T_f}$$

**C<sub>ft/s</sub>** = speed of sound in feet per second  
**T<sub>f</sub>** = temperature in °F

### Temperature Compensation

Changes in air temperature affect the speed of sound, which in turn affects the distance reading measured by the sensor. An increase in air temperature shifts both sensing window limits closer to the sensor. Conversely, a decrease in air temperature shifts both limits farther away from the sensor. This shift is approximately 3.5% of the limit distance for a 20° C change in temperature.

The QS18U series ultrasonic sensors are temperature compensated. This reduces the error due to temperature by about 90%. The sensor will maintain its window limits to within 1.8% over the -20° to +60° C range.

#### NOTES:

- Exposure to direct sunlight can affect the sensor's ability to accurately compensate for changes in temperature.
- If the sensor is measuring across a temperature gradient, the compensation will be less effective.
- The temperature warmup drift upon power-up is less than 7% of the sensing distance. After 5 minutes, the apparent switchpoint will be within 0.6% of the actual position. After 25 minutes, the sensing position will be stable.

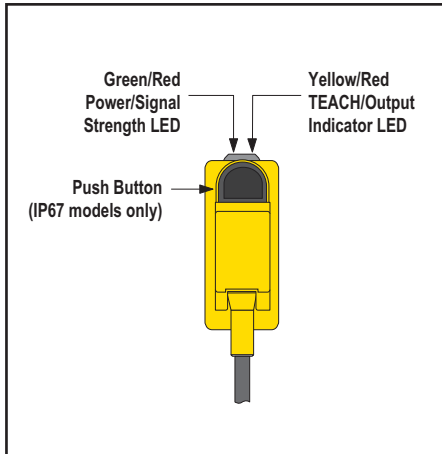

Figure 1. Sensor features

## Sensor Programming

Two TEACH methods may be used to program the sensor:

- Teach individual minimum and maximum limits, or
- Use Auto-Window feature to center a sensing window around the taught position.

The sensor may be programmed either via its push button, or via a remote switch. Remote programming also may be used to disable the push button, preventing unauthorized personnel from adjusting the programming settings. To access this feature, connect the white wire of the sensor to 0V dc, with a remote programming switch between the sensor and the voltage.

Programming is accomplished by following the sequence of input pulses (see programming procedures starting on page 4). The duration of each pulse (corresponding to a push button “click”), and the period between multiple pulses, are defined as “T”:

$$0.04 \text{ seconds} < T < 0.8 \text{ seconds}$$

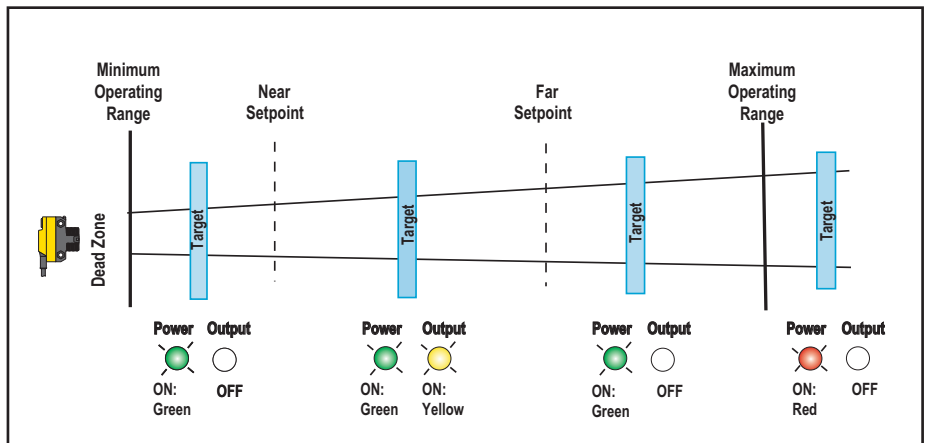

Figure 2. TEACH Interface

## Status Indicators

Power ON/OFF LED	Indicates
OFF	Power is OFF.
ON Red	Target is weak or outside sensing range.
ON Green	Sensor is operating normally, good target.

Output/Teach LED	Indicates
OFF	Target is outside window limits (normally open operation).
Yellow	Target is within window limits (normally open operation).
ON Red (solid)	In Teach Mode, waiting for first limit
ON Red (flashing)	In Teach Mode, waiting for second limit

# WORLD BEAM® QS18U Series Ultrasonic Sensors

## Teaching Minimum and Maximum Limits

### General Notes on Programming

- The sensor will return to RUN mode if the first TEACH condition is not registered within 120 seconds.
- After the first limit is taught, the sensor will remain in PROGRAM mode until the TEACH sequence is finished.
- To exit PROGRAM mode without saving any changes, press and hold the programming push button > 2 seconds (before teaching the second limit). The sensor will revert to the last saved limits.

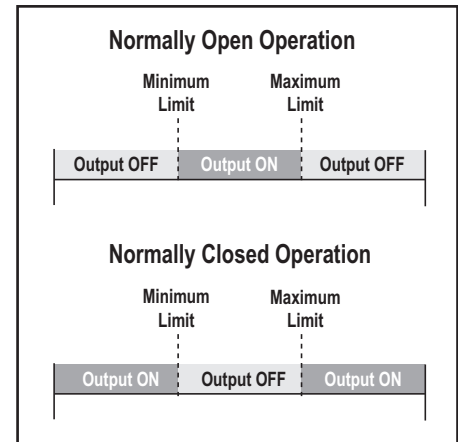







Figure 3. Teaching independent minimum and maximum limits

	Procedure		Result
	Push Button 0.04 sec. < “click” < 0.8 sec.	Remote Line 0.04 sec. < T < 0.8 sec.	
Programming Mode	<ul style="list-style-type: none"> <li>• Push and hold push button</li> </ul> 	<ul style="list-style-type: none"> <li>• No action required; sensor is ready for 1st limit teach</li> </ul>	<b>Output LED:</b> ON Red <b>Power LED:</b> ON Green (good signal) or ON Red (no signal)
Teach First Limit	<ul style="list-style-type: none"> <li>• Position the target for the first limit</li> </ul>	<ul style="list-style-type: none"> <li>• Position the target for the first limit</li> </ul>	<b>Power LED:</b> Must be ON Green
	<ul style="list-style-type: none"> <li>• “Click” the push button</li> </ul> 	<ul style="list-style-type: none"> <li>• Single-pulse the remote line</li> </ul> 	<b>Teach Accepted</b> <b>Output LED:</b> Flashing Red <b>Teach Unacceptable</b> <b>Output LED:</b> ON Red
Teach Second Limit	<ul style="list-style-type: none"> <li>• Position the target for the second limit</li> </ul>	<ul style="list-style-type: none"> <li>• Position the target for the second limit</li> </ul>	<b>Power LED:</b> Must be ON Green
	<ul style="list-style-type: none"> <li>• “Click” the push button</li> </ul> 	<ul style="list-style-type: none"> <li>• Single-pulse the remote line</li> </ul> 	<b>Teach Accepted</b> <b>Output LED:</b> Yellow or OFF <b>Teach Unacceptable</b> <b>Output LED:</b> Flashing Red

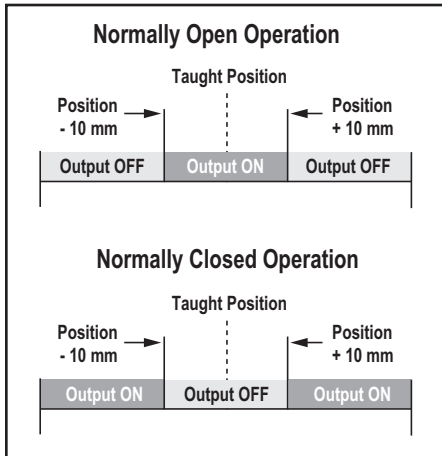







Figure 4. Using the Auto-Window feature for programming each output

## Teaching Limits Using the Auto-Window Feature

Teaching the same limit twice automatically centers a 20 mm window on the taught position.

### General Notes on Programming

- The sensor will return to RUN mode if the first TEACH condition is not registered within 120 seconds.
- After the first limit is taught, the sensor will remain in PROGRAM mode until the TEACH sequence is finished.
- To exit PROGRAM mode without saving any changes, press and hold the programming push button > 2 seconds (before teaching the second limit). The sensor will revert to the last saved program.

	Procedure		Result
	Push Button 0.04 sec. < "click" < 0.8 sec.	Remote Line 0.04 sec. < T < 0.8 sec.	
<b>Programming Mode</b>	<ul style="list-style-type: none"> <li>• Push and hold push button</li> </ul> 	<ul style="list-style-type: none"> <li>• No action required; sensor is ready for 1st limit teach</li> </ul>	<b>Output LED:</b> ON Red <b>Power LED:</b> ON Green (good signal) or ON Red (no signal)
<b>Teach Limit</b>	<ul style="list-style-type: none"> <li>• Position the target for the first limit</li> </ul>	<ul style="list-style-type: none"> <li>• Position the target for the center of window</li> </ul>	<b>Power LED:</b> Must be ON Green
	<ul style="list-style-type: none"> <li>• "Click" the push button</li> </ul> 	<ul style="list-style-type: none"> <li>• Single-pulse the remote line</li> </ul> 	<b>Teach Accepted</b> <b>Output LED:</b> Flashing Red <b>Teach Unacceptable</b> <b>Output LED:</b> ON Red
<b>Re-Teach Limit</b>	<ul style="list-style-type: none"> <li>• Without moving the target, "click" the push button again</li> </ul> 	<ul style="list-style-type: none"> <li>• Without moving the target, single-pulse the remote line again</li> </ul> 	<b>Teach Accepted</b> <b>Output LED:</b> Yellow or OFF <b>Teach Unacceptable</b> <b>Output LED:</b> Flashing Red

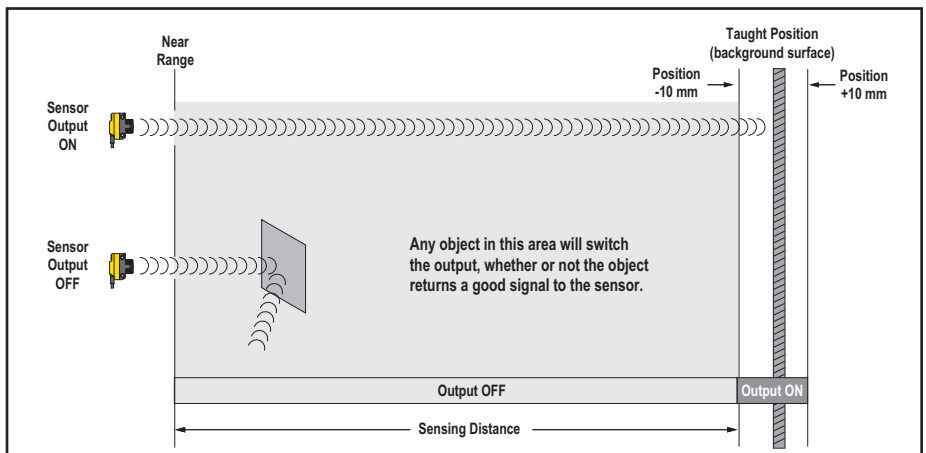



Figure 5. An application for the Auto-Window feature (retroreflective mode)

# WORLD BEAM® QS18U Series Ultrasonic Sensors

## Normally Open/Normally Closed Operation Select

The sensor can be configured for either normally open or normally closed operation via the remote teach wire (white). A series of three pulses on the line will toggle between normally open and normally closed operation. Normally open is defined as the output energizing when the target is present. Normally closed is defined as the output energizing when the target is absent. See Figures 3 and 4.

	Procedure		Result
	Push Button	Remote Line 0.04 sec. < T < 0.8 sec.	
Toggle between N.O. / N.C. Operation	<ul style="list-style-type: none"> <li>Not available via push button</li> </ul>	<ul style="list-style-type: none"> <li>Triple-pulse the remote line</li> </ul> 	<ul style="list-style-type: none"> <li>Either Normally Open or Normally Closed operation is selected, depending on previous condition.</li> </ul>

## Push Button Lockout

Enables or disables the push button to prevent unauthorized personnel from adjusting the program settings.

	Procedure		Result
	Push Button	Remote Line 0.04 sec. < T < 0.8 sec.	
Push Button Lockout	<ul style="list-style-type: none"> <li>Not available via push button</li> </ul>	<ul style="list-style-type: none"> <li>Four-pulse the remote line</li> </ul> 	<ul style="list-style-type: none"> <li>Push buttons are either enabled or disabled, depending on condition.</li> </ul>

# WORLD BEAM® QS18U Series Ultrasonic Sensors

## Specifications

<b>Sensing Range</b>	50 to 500 mm (2" to 20")	
<b>Supply Voltage</b>	12 to 30V dc (10% maximum ripple); 25 mA max. (exclusive of load)	
<b>Ultrasonic Frequency</b>	300 kHz, rep. rate 7.5 ms	
<b>Supply Protection Circuitry</b>	Protected against reverse polarity and transient voltages	
<b>Output Configuration</b>	SPST solid-state switch conducts when target is sensed within sensing window; one NPN (current sinking) or one PNP (current sourcing), depending on model.	
<b>Output Protection</b>	Protected against short circuit conditions	
<b>Output Ratings</b>	100 mA maximum load; see Application Note 1 <b>OFF-state leakage current:</b> < 10 microamps (sourcing); < 200 microamp (sinking); see Application Note 2 <b>NPN saturation:</b> < 1.6V @ 100 mA <b>PNP saturation:</b> < 3.0V @ 100 mA	
<b>Output Response Time</b>	15 milliseconds	
<b>Delay at Power-Up</b>	300 milliseconds	
<b>Temperature Effect</b>	<b>Non-encapsulated models:</b> ± 0.05% per °C from -20° to +50° C, ± 0.1% per °C from +50° to +60° C <b>Encapsulated models:</b> ± 0.05% per °C from 0° to +60° C, ± 0.1% per °C from -20° to 0° C	
<b>Repeatability</b>	0.7 mm	
<b>Minimum Window Size</b>	5 mm	
<b>Hysteresis</b>	1.4 mm	
<b>Adjustments</b>	<b>Sensing window limits:</b> TEACH-mode programming of near and far window limits may be set using the push button or remotely via TEACH input (see page 3).	
<b>Indicators</b>	<b>Range Indicator (Red/Green)</b> <b>Green</b> — Target is within sensing range <b>Red</b> — Target is outside sensing range <b>OFF</b> — Sensing power is OFF	<b>Teach/Output Indicator (Yellow/Red)</b> <b>Yellow</b> — Target is within taught limits <b>OFF</b> — Target is outside taught window limits <b>Red</b> — Sensor is in TEACH mode
<b>Construction</b>	<b>Housing:</b> ABS <b>Push Button:</b> TPE	<b>Push Button Housing:</b> ABS <b>Lightpipes:</b> Polycarbonate
<b>Environmental Rating</b>	Leakproof design, rated NEMA 6P; IEC IP67 or IP68, depending on model (see page 1); UL type 1	
<b>Connections</b>	2 m (6.5') or 9 m (30') 4-conductor PVC jacketed attached cable or 4-pin Euro-style integral QD ( <b>Q8</b> ), or 4-pin Pico-style integral QD ( <b>Q7</b> ), or 4-pin Euro-style 150 mm (6") pigtail QD ( <b>Q5</b> ), or 4-pin Pico-style 150 mm (6") pigtail QD ( <b>Q</b> )	
<b>Operating Conditions</b>	<b>Temperature:</b> -20° to +60°C (-4° to +140°F) <b>Maximum relative humidity:</b> 100%, non-condensing	
<b>Vibration and Mechanical Shock</b>	All models meet Mil. Std. 202F requirements method 201A (vibration: 10 to 60 Hz max., double amplitude 0.06", maximum acceleration 10G). Also meets IEC 947-5-2 requirements: 30G 11 ms duration, half sine wave.	
<b>Temperature Warmup Drift</b>	See Temperature Compensation, page 2	
<b>Application Note</b>	1. If supply voltage is > 24V dc, derate maximum output current 5 mA/°C above 50°C. 2. NPN OFF-state leakage current is < 200 µA for load resistances > 3 kΩ or optically isolated loads. For load current of 100 mA, leakage is < 1% of load current. 3. Objects passing inside the specified near limit may produce a false response.	
<b>Certifications</b>		

# WORLD BEAM® QS18U Series Ultrasonic Sensors

## Sensor Response Curves

QS18U Effective Beam Pattern (Typical)

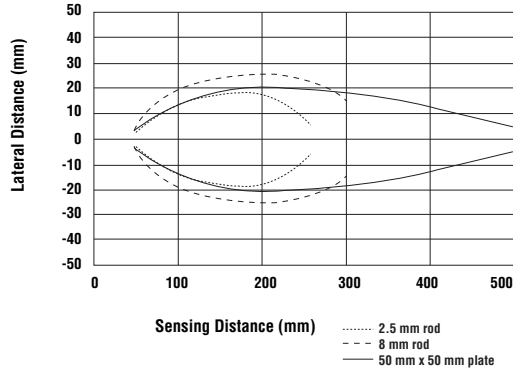

QS18U Maximum Target Rotation Angle

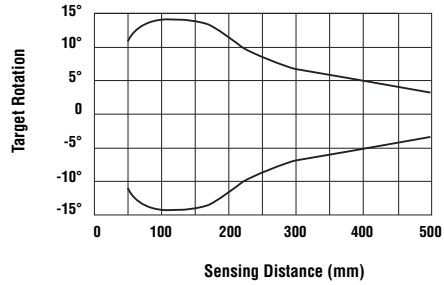

## Hookups

NPN (Sinking) Output Models

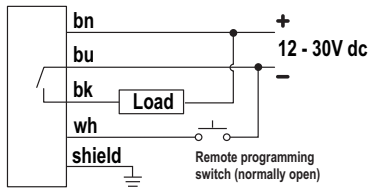

PNP (Sourcing) Output Models

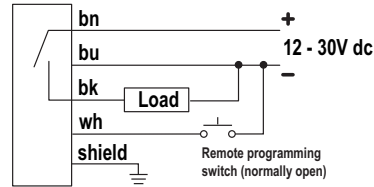

Cable and QD hookups are functionally identical.

It is recommended that the shield wire be connected to earth ground. Shielded cordsets are recommended for all QD models.

## Dimensions

Cabled Models

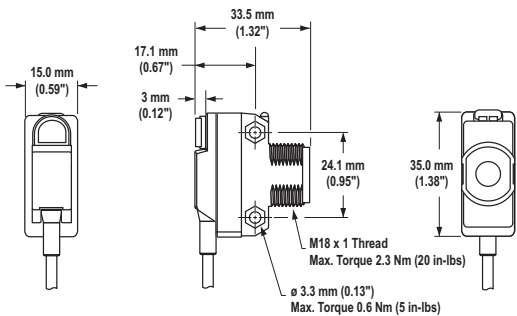

Pico-Style QD Models

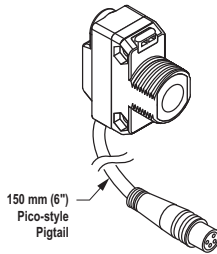

Euro-Style QD Models

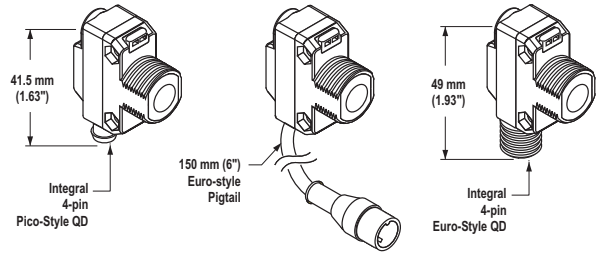

Locknut (Included with All Models)

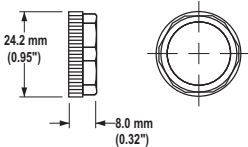

Washer (Included with All Models)

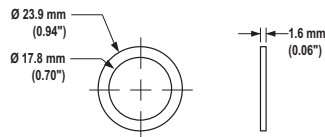

### M3 Hardware Packet Contents:

- 2 – M3 x 0.5 x 20 mm SS Screw
- 2 – M3 x 0.5 SS Hex Nut
- 2 – M3 SS Washer



# WORLD BEAM® QS18U Series Ultrasonic Sensors

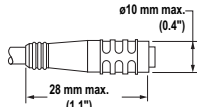
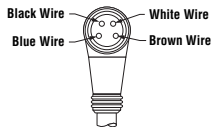
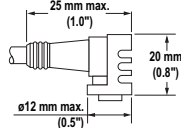
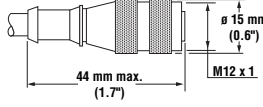
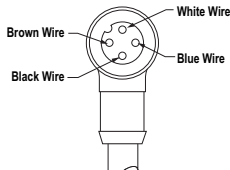
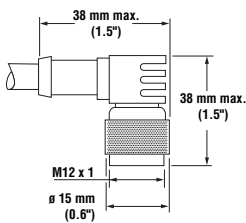

## Accessories

### Quick-Disconnect Cordsets

Style	Model	Length	Dimensions	Pinout
4-pin Pico-style Straight with shield, snap-on connector	<b>PKG4S-2</b>	2 m (6.5')		
4-pin Pico-style Right-angle with shield, snap-on connector	<b>PKW4ZS-2</b>	2 m (6.5')		
4-pin Euro-style Straight with shield	<b>MQDEC2-406</b> <b>MQDEC2-415</b> <b>MQDEC2-430</b>	2 m (6.5') 5 m (15') 9 m (30')		
4-pin Euro-style Right-angle with shield	<b>MQDEC2-406RA</b> <b>MQDEC2-415RA</b> <b>MQDEC2-430RA</b>	2 m (6.5') 5 m (15') 9 m (30')		

# WORLD BEAM® QS18U Series Ultrasonic Sensors

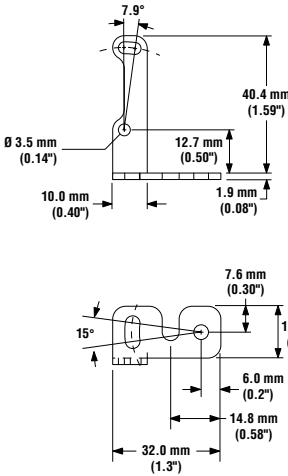
## Mounting Brackets

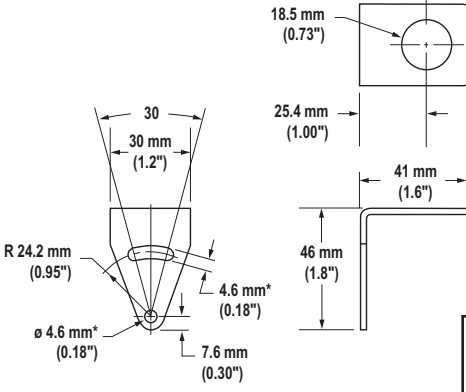
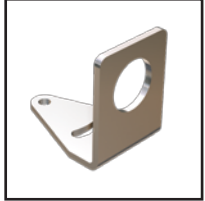
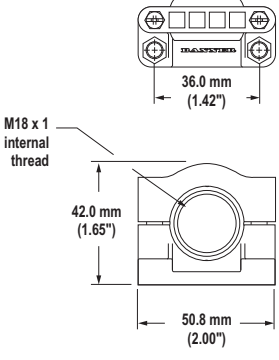
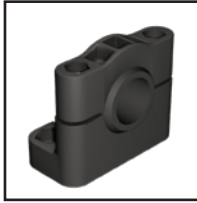
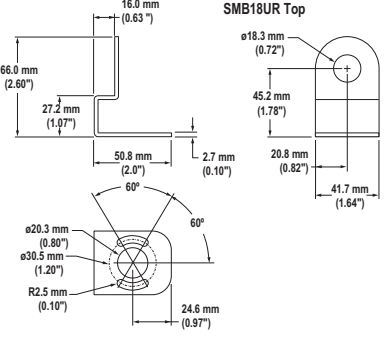
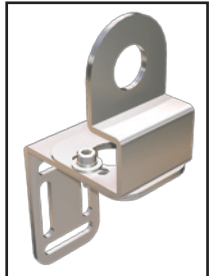
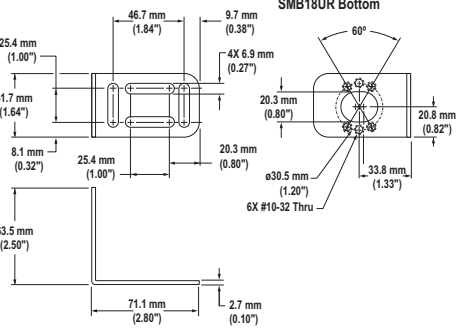
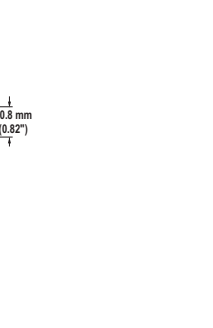
<p><b>SMBQS18RA</b></p>	<ul style="list-style-type: none"> <li>• 304 stainless steel</li> <li>• Right-angle bracket</li> <li>• NOTE: Integral QD models must mount to the "outside" to allow clearance</li> </ul>	<p><b>SMB18A</b></p>	<ul style="list-style-type: none"> <li>• 12-gauge, stainless steel, right-angle mounting bracket with a curved mounting slot for versatility and orientation</li> <li>• Clearance for M4 (#8) hardware</li> </ul>
 		 <p>* Use 4 mm (#8) screws to mount bracket. Drill screw holes 24.2 mm (0.95") apart.</p> 	
<p><b>SMB18SF</b></p>	<ul style="list-style-type: none"> <li>• 18 mm swivel bracket</li> <li>• Black thermoplastic polyester</li> <li>• Includes stainless steel hardware</li> </ul>	<p><b>SMB18UR</b></p>	<ul style="list-style-type: none"> <li>• 2-piece universal 18 mm swivel bracket</li> <li>• 300 series stainless steel</li> <li>• Includes stainless steel swivel locking hardware</li> </ul>
 		 	 



# WORLD BEAM® QS18U Series Ultrasonic Sensors

---



**WARRANTY:** Banner Engineering Corp. warrants its products to be free from defects for one year. Banner Engineering Corp. will repair or replace, free of charge, any product of its manufacture found to be defective at the time it is returned to the factory during the warranty period. This warranty does not cover damage or liability for the improper application of Banner products. This warranty is in lieu of any other warranty either expressed or implied.

P/N 119287 rev. E

Banner Engineering Corp., 9714 Tenth Ave. No., Minneapolis, MN USA 55441 • Phone: 763.544.3164 • [www.bannerengineering.com](http://www.bannerengineering.com) • Email: [sensors@bannerengineering.com](mailto:sensors@bannerengineering.com)