



Industrial Automation Headquarters

Delta Electronics, Inc.
Taoyuan Technology Center
No.18, Xinglong Rd., Taoyuan City,
Taoyuan County 33068, Taiwan
TEL: 886-3-362-6301 / FAX: 886-3-371-6301

Asia

Delta Electronics (Jiangsu) Ltd.
Wujiang Plant 3
1688 Jiangxing East Road,
Wujiang Economic Development Zone
Wujiang City, Jiang Su Province, P.R.C. 215200
TEL: 86-512-6340-3008 / FAX: 86-769-6340-7290

Delta Greentech (China) Co., Ltd.
238 Min-Xia Road, Pudong District,
Shanghai, P.R.C. 201209
TEL: 86-21-58635678 / FAX: 86-21-58630003

Delta Electronics (Japan), Inc.
Tokyo Office
2-1-14 Minato-ku Shibadaimon,
Tokyo 105-0012, Japan
TEL: 81-3-5733-1111 / FAX: 81-3-5733-1211

Delta Electronics (Korea), Inc.
1511, Byucksan Digital Valley 6-cha, Gasan-dong,
Geumcheon-gu, Seoul, Korea, 153-704
TEL: 82-2-515-5303 / FAX: 82-2-515-5302

Delta Electronics Int'l (S) Pte Ltd.
4 Kaki Bukit Ave 1, #05-05, Singapore 417939
TEL: 65-6747-5155 / FAX: 65-6744-9228

Delta Electronics (India) Pvt. Ltd.
Plot No 43 Sector 35, HSIIDC
Gurgaon, PIN 122001, Haryana, India
TEL : 91-124-4874900 / FAX : 91-124-4874945

Americas

Delta Products Corporation (USA)
Raleigh Office
P.O. Box 12173, 5101 Davis Drive,
Research Triangle Park, NC 27709, U.S.A.
TEL: 1-919-767-3800 / FAX: 1-919-767-8080

Delta Greentech (Brasil) S.A.
Sao Paulo Office
Rua Itapeva, 26 - 3° andar Edificio Itapeva One-Bela Vista
01332-000-São Paulo-SP-Brazil
TEL: 55 11 3568-3855 / FAX: 55 11 3568-3865

Europe

Deltronics (The Netherlands) B.V.
Eindhoven Office
De Witbogt 20, 5652 AG Eindhoven, The Netherlands
TEL: 31-40-2592850 / FAX: 31-40-2592851

AH-0109520-02

*We reserve the right to change the information in this manual without prior notice.

2014-05-16

AH500 Hardware Manual



AH500 Hardware Manual

www.deltaww.com



AH500 Hardware Manual

Revision History

Version	Revision	Date
First version	The first version was published.	2012/11/09
Second version	<ol style="list-style-type: none"> 1. The information about AHPS15-5A, AH32AM10N-5A, AH32AM10N-5C, AH16AR10N-5A, AH32AN02T-5A, AH32AN02T-5C, AH32AN02P-5A, AH32AN02P-5C, AH08AD-5C, AH08DA-5C, AH08PTG-5A, AH15PM-5A, AH10PFBM-5A, AH10PFBS-5A, AH10COPM-5A, AHRTU-PFBS-5A, AHAADP01EF-5A/AHAADP02EF-5A, and DVPAETB-IO34C are added to all the chapters. 2. The descriptions of the modules in Chapter 1 are updated. 3. The storage temperature, the program capacity of AHCPU500, the specifications for the input/output relays, the specifications for AH16AR10N-5A, the functional specifications for analog input/output modules, the electrical specifications for the temperature measurement modules, the specifications for AH02HC-5A/AH04HC-5A, and the response characteristics of the input terminals on AH05PM-5A/AH10PM-5A in Chapter 3 are updated. 4. The figures in Chapter 4 are updated. 5. The wiring diagrams in Chapter 5 are updated. 6. The arrangement of the terminals in section 5.10.2 is updated. 7. The error code 16#005D is added to section 9.1.2, and the error codes 16#6500~16#6502 are added to section 9.1.5. The information about AH15PM-5A is added to section 9.2.3. Section 9.2.8~section 9.2.10 are new sections. 	2014/05/16

AH500 Hardware Manual

Table of Contents

Chapter 1 Introduction of Products

1.1	Overview	1-2
1.1.1	Related Manuals.....	1-2
1.1.2	Description of Models.....	1-2
1.2	Characteristics.....	1-8

Chapter 2 Installing Hardware

2.1	AH500 Hardware Framework.....	2-2
2.1.1	Component Parts of AH500 Hardware	2-2
2.1.1.1	Necessary Components	2-2
2.1.1.2	Accessories.....	2-4
2.1.2	Installing Modules on a Main Backplane	2-8
2.1.3	Installing Modules on an Extension Backplane	2-9
2.1.4	Connecting a Main Backplane to an Extension Backplane	2-9
2.2	Warning.....	2-9
2.3	Installation	2-10
2.3.1	Installation of Modules in a Control Box	2-10
2.3.2	Mounting a Backplane.....	2-10
2.3.3	Installing a Module.....	2-13
2.3.4	Installing a Removable Terminal Block.....	2-14
2.3.5	Installing a Wiring Module	2-15
2.3.6	Connecting Backplanes.....	2-16
2.3.7	Connecting a Communication Cable	2-18

Chapter 3 Specifications for Products

3.1	General Specifications	3-2
3.2	Specifications for CPU Modules.....	3-2
3.2.1	General Specifications.....	3-2
3.2.2	Profiles	3-4
3.2.3	Dimensions.....	3-5
3.3	Specifications for Backplanes	3-6
3.3.1	General Specifications.....	3-6
3.3.2	Profiles	3-7
3.3.3	Dimensions.....	3-9

3.4	Specifications for the Power Supply Module	3-11
3.4.1	General Specifications	3-11
3.4.2	Profile	3-12
3.4.3	Dimensions.....	3-13
3.4.4	Arrangement of Terminals.....	3-14
3.5	Specifications for Digital Input/Output Modules	3-15
3.5.1	General Specifications	3-15
3.5.2	Profiles	3-18
3.5.3	Dimensions.....	3-25
3.5.4	Arrangement of Input/Output Terminals	3-30
3.6	Specifications for Analog Input/Output Modules	3-40
3.6.1	General Specifications	3-40
3.6.2	Profiles	3-45
3.6.3	Dimensions.....	3-46
3.6.4	Arrangement of Input/Output Terminals	3-47
3.7	Specifications for Temperature Measurement Modules.....	3-48
3.7.1	General Specifications	3-48
3.7.2	Profiles	3-50
3.7.3	Dimensions.....	3-52
3.7.4	Arrangement of Input/Output Terminals	3-53
3.8	Specifications for Network Modules	3-54
3.8.1	General Specifications	3-54
3.8.2	Profiles	3-57
3.8.3	Dimensions.....	3-64
3.8.4	Arrangement of Input/Output Terminals	3-67
3.9	Specifications for Motion Control Modules.....	3-68
3.9.1	General Specifications	3-68
3.9.2	Profiles	3-80
3.9.3	Dimensions.....	3-87
3.9.4	Arrangement of Input/Output Terminals.....	3-91
3.10	Specifications for the Remote I/O Modules.....	3-96
3.10.1	General Specifications	3-96
3.10.2	Profiles	3-97
3.10.3	Dimensions.....	3-99
3.11	Space Module and Extension Cables	3-100
3.11.1	General Specifications	3-100
3.11.2	Profiles	3-101
3.11.3	Dimensions.....	3-102

Chapter 4 Assigning Addresses

4.1	Assigning I/O Addresses	4-2
4.2	Software-defined Addresses	4-3
4.2.1	Start Addresses for Digital Input/Output Modules	4-3
4.2.2	Start Addresses for Analog Input/Output Modules	4-4
4.2.3	Start Addresses for Temperature Measurement Modules.....	4-4
4.2.4	Start Addresses for Motion Control Modules.....	4-5
4.2.5	Start Addresses for Network Modules	4-6
4.3	User-defined Addresses.....	4-6
4.3.1	Start Addresses for Digital Input/Output Modules	4-6
4.3.2	Start Addresses for Analog Input/Output Modules	4-7
4.3.3	Start Addresses for Temperature Measurement Modules.....	4-8
4.3.4	Start Addresses for Motion Control Modules.....	4-8
4.3.5	Start Addresses for Network Modules	4-9

Chapter 5 Wiring

5.1	Wiring	5-3
5.2	Connecting Power Cables.....	5-4
5.2.1	Precautions	5-4
5.2.2	Ground	5-5
5.2.3	Wiring Power Supply Modules.....	5-6
5.2.4	Power Consumption	5-8
5.3	Wiring CPU Modules.....	5-10
5.4	Wiring Digital Input/Output Modules.....	5-11
5.4.1	Wiring AH16AM10N-5A	5-11
5.4.2	Wiring AH16AM30N-5A	5-12
5.4.3	Wiring AH16AR10N-5A	5-13
5.4.4	Wiring AH16AN01S-5A.....	5-14
5.4.5	Wiring AH16AN01R-5A	5-15
5.4.6	Wiring AH16AN01T-5A	5-16
5.4.7	Wiring AH16AN01P-5A.....	5-17
5.4.8	Wiring AH16AP11R-5A.....	5-18
5.4.9	Wiring AH16AP11T-5A	5-19
5.4.10	Wiring AH16AP11P-5A.....	5-20
5.4.11	Wiring AH32AM10N-5A.....	5-21
5.4.12	Wiring AH32AM10N-5B.....	5-22
5.4.13	Wiring AH32AM10N-5C	5-23

5.4.14	Wiring AH32AN02T-5A.....	5-24
5.4.15	Wiring AH32AN02T-5B.....	5-25
5.4.16	Wiring AH32AN02T-5C	5-26
5.4.17	Wiring AH32AN02P-5A	5-28
5.4.18	Wiring AH32AN02P-5B	5-29
5.4.19	Wiring AH32AN02P-5C	5-30
5.4.20	Wiring AH64AM10N-5C	5-32
5.4.21	Wiring AH64AN02T-5C	5-33
5.4.22	Wiring AH64AN02P-5C	5-34
5.5	Wiring Digital Input/Output Terminals	5-35
5.5.1	Wiring Digital Input Terminals	5-35
5.5.1.1	Sinking and Sourcing	5-35
5.5.1.2	Relay Type	5-36
5.5.1.3	Open-collector Input Type	5-36
5.5.1.4	Two-wire Proximity Switch	5-37
5.5.1.5	Three-wire Switch	5-37
5.5.1.6	Optoelectronic Switch	5-38
5.5.1.7	Voltage Input (120~240 V AC).....	5-38
5.5.2	Wiring Digital Output Terminals	5-39
5.5.2.1	Output Circuits	5-39
5.5.2.2	Relay Output Circuit	5-40
5.5.2.3	Transistor Output Circuit	5-42
5.5.2.4	TRIAC Output Circuit	5-44
5.6	Wiring Analog Input/Output Modules	5-45
5.6.1	Wiring AH04AD-5A.....	5-45
5.6.2	Wiring AH08AD-5B.....	5-46
5.6.3	Wiring AH08AD-5C.....	5-46
5.6.4	Wiring AH04DA-5A.....	5-47
5.6.5	Wiring AH08DA-5B.....	5-48
5.6.6	Wiring AH08DA-5C.....	5-49
5.6.7	Wiring AH06XA-5A	5-50
5.7	Wiring Temperature Measurement Modules.....	5-51
5.7.1	Wiring AH04PT-5A	5-51
5.7.2	Wiring AH08PTG-5A	5-52
5.7.3	Wiring AH04TC-5A	5-53
5.7.4	Wiring AH08TC-5A	5-53
5.8	Wiring Network Modules	5-53
5.8.1	Wiring AH10DNET-5A	5-53

5.8.1.1	DeviceNet Connector	5-53
5.8.1.2	Connecting a Cable to the DeviceNet Connector.....	5-54
5.8.1.3	Installing the DeviceNet Connector	5-54
5.8.2	Wiring AH10EN-5A	5-55
5.8.3	Wiring AH10SCM-5A	5-55
5.8.4	Wiring AH10PFBM-5A/AH10PFBS-5A	5-55
5.8.4.1	Connecting the PROFIBUS-DP Connector	5-55
5.8.4.2	Definitions of the Pins in the PROFIBUS-DP Port.....	5-56
5.8.4.3	Setting a PROFIBUS Node Address by the Knobs	5-56
5.8.5	Wiring AH10COPM-5A	5-57
5.8.5.1	CANopen Communication Connector	5-57
5.8.5.2	Address Knobs	5-57
5.8.5.3	Function Switch	5-58
5.9	Wiring Remote I/O Modules	5-58
5.9.1	Wiring AHRTU-DNET-5A.....	5-58
5.9.1.1	DeviceNet Connector	5-58
5.9.1.2	Connecting a Cable to the DeviceNet Connector.....	5-58
5.9.1.3	Installing the DeviceNet Connector	5-59
5.9.2	Wiring AHRTU-PFBS-5A	5-60
5.9.2.1	Connecting the PROFIBUS-DP Connector	5-60
5.9.2.2	Definitions of the Pins in the PROFIBUS-DP Port.....	5-60
5.9.2.3	Setting a PROFIBUS Node Address by the Knobs	5-60
5.9.3	Wiring AHAADP01EF-5A/AHAADP02EF-5A.....	5-61
5.9.3.1	Connecting 100BASE-FX Fibers.....	5-61
5.9.3.2	Specifications for Cables.....	5-61
5.9.3.3	Installing AHAADP01EF-5A/AHAADP02EF-5A on a Backplane.....	5-61
5.10	Wiring Motion Control Modules	5-62
5.10.1	Specifications for Motion Control Modules	5-62
5.10.2	I/O Extension Cables and External Terminal Modules	5-73
5.10.3	Wiring AH02HC-5A and AH04HC-5A	5-75
5.10.3.1	External Wiring.....	5-77
5.10.3.2	Wiring the Differential Input Terminals.....	5-77
5.10.3.3	Transistor Output Circuit	5-78
5.10.4	Wiring AH05PM-5A, AH10PM-5A, and AH15PM-5A.....	5-79
5.10.4.1	Wiring Input Terminals.....	5-82
5.10.4.2	Wiring the Output Terminals.....	5-84
5.10.4.3	Wiring AH10PM-5A and an Inferior Servo Drive.....	5-86
5.10.5	Wiring AH20MC-5A	5-91

5.10.5.1	Wiring the Differential Input Terminals.....	5-92
5.10.5.2	Transistor Output Circuit	5-92

Chapter 6 Memory Card

6.1	Overview of Memory Cards.....	6-2
6.1.1	Appearances of Memory Cards.....	6-2
6.1.2	Specifications for Memory Cards.....	6-2
6.2	Installing and Removing a Memory Card	6-3
6.2.1	Formatting of a Memory Card and a Write Protect Tab	6-3
6.2.2	SD Slot in a CPU Module	6-3
6.2.3	Installing a Memory Card	6-4
6.2.4	Removing a Memory Card	6-4

Chapter 7 EMC Standards

7.1	EMC Standards for an AH500 System.....	7-2
7.1.1	EMC Standards Applicable to an AH500 System	7-2
7.1.2	Installation Instructions for the EMC Standards.....	7-3
7.1.3	Cables	7-3

Chapter 8 Maintenance and Inspection

8.1	Cautions	8-2
8.2	Daily Maintenance.....	8-2
8.2.1	Tools Required for Inspection.....	8-2
8.2.2	Daily Inspection	8-3
8.3	Periodic Maintenance.....	8-3
8.3.1	Tools Required for Inspection.....	8-4
8.3.2	Periodic Inspection	8-4

Chapter 9 Troubleshooting

9.1	Troubleshooting for CPU Modules	9-2
9.1.1	ERROR LED Indicator's Being ON	9-2
9.1.2	ERROR LED Indicator's Blinking	9-3
9.1.3	BUS FAULT LED Indicator's Being ON	9-10
9.1.4	BUS FAULT LED Indicator's Blinking	9-11
9.1.5	Others.....	9-11
9.2	Troubleshooting for I/O Modules.....	9-21
9.2.1	Troubleshooting for Analog I/O Modules and Temperature Measurement Modules	9-21

9.2.2	Troubleshooting for AH02HC-5A/AH04HC-5A	9-24
9.2.3	Troubleshooting for AH05PM-5A/AH10PM-5A/AH15PM-5A	9-25
9.2.4	Troubleshooting for AH20MC-5A.....	9-27
9.2.5	Troubleshooting for AH10EN-5A	9-28
9.2.6	Troubleshooting for AH10SCM-5A	9-28
9.2.7	Troubleshooting for AH10DNET-5A.....	9-29
9.2.8	Troubleshooting for AH10PFBM-5A	9-30
9.2.9	Troubleshooting for AH10PFBS-5A.....	9-31
9.2.10	Troubleshooting for AH10COPM-5A	9-31



Chapter 1 Introduction of Products

Table of Contents

1.1	Overview	1-2
1.1.1	Related Manuals.....	1-2
1.1.2	Description of Models.....	1-2
1.2	Characteristics.....	1-8



1.1 Overview

This manual introduces the programming of the AH500 series programmable logic controllers, the basic instructions, and the applied instructions. This manual introduces the electrical specifications for the AH500 series programmable logic controllers, the appearances, the dimensions, and etc.

1.1.1 Related Manuals

The related manuals of the AH500 series programmable logic controllers are composed of the following.

- **AH500 Quick Start**
It guides users to use the system before they read the related manuals.
- **AH500 Programming Manual**
It introduces the programming of the AH500 series programmable logic controllers, the basic instructions, and the applied instructions.
- **ISPSOFT User Manual**
It introduces the use of ISPSOFT, the programming language (Ladder, IL, SFC, FBD, and ST), the concept of POU, and the concept of tasks.
- **AH500 Hardware Manual**
It introduces electrical specifications, appearances, dimensions, and etc.
- **AH500 Operation Manual**
It introduces functions of CPUs, devices, module tables, troubleshooting, and etc.
- **AH500 Module Manual**
It introduces the use of special I/O modules. For example, network modules, analog I/O modules, temperature measurement modules, motion control modules, and etc.
- **AH500 Motion Control Module Manual**
It introduces the specifications for the motion control modules, the wiring, the instructions, and the functions.
- **PMSOFT User Manual**
It introduces the use of PMSOFT, including the editing mode, the connection, and the password setting.

1.1.2 Description of Models

Classification	Model Name	Description
Power supply module	AHPS05-5A	100~240 V AC 50/60 Hz
	AHPS15-5A	24 V DC
CPU module	AHCPU500-RS2	It is a basic CPU module with two built-in RS-485 ports, one built-in USB port, and one built-in SD interface. It supports 768 inputs/outputs. The program capacity is 32K steps.
	AHCPU500-EN	It is a basic CPU module with one built-in Ethernet port, one built-in RS-485 port, one built-in USB port, and one built-in SD interface. It supports 768 inputs/outputs. The program capacity is 32K steps.
	AHCPU510-RS2	It is a basic CPU module with two built-in RS-485 ports, one built-in USB port, and one built-in SD interface. It supports 1280 inputs/outputs. The program capacity is 64K steps.
	AHCPU510-EN	It is a basic CPU module with one built-in Ethernet port, one built-in RS-485 port, one built-in USB port, and one built-in SD interface. It supports 1280 inputs/outputs. The program capacity is 64K steps.
	AHCPU520-RS2	It is a basic CPU module with two built-in RS-485 ports, one built-in USB port, and one built-in SD interface. It supports 2304 inputs/outputs. The program capacity is 128K steps.
	AHCPU520-EN	It is a basic CPU module with one built-in Ethernet port, one built-in RS-485 port, one built-in USB port, and one built-in SD interface. It supports 2304 inputs/outputs. The program capacity is 128K steps.

Classification	Model Name	Description
CPU module	AHCPU530-RS2	It is a basic CPU module with two built-in RS-485 ports, one built-in USB port, and one built-in SD interface. It supports 4352 inputs/outputs. The program capacity is 256K steps.
	AHCPU530-EN	It is a basic CPU module with one built-in Ethernet port, one built-in RS-485 port, one built-in USB port, and one built-in SD interface. It supports 4352 inputs/outputs. The program capacity is 256K steps.
Main backplane	AHBP04M1-5A	Four-slot main backplane for a CPU/RTU rack
	AHBP06M1-5A	Six-slot main backplane for a CPU/RTU rack
	AHBP08M1-5A	Eight-slot main backplane for a CPU/RTU rack
	AHBP12M1-5A	Twelve-slot main backplane for a CPU/RTU rack
Extension backplane	AHBP06E1-5A	Six-slot extension backplane for a CPU/RTU extension rack
	AHBP08E1-5A	Eight-slot extension backplane for a CPU/RTU extension rack
Digital input/output module	AH16AM10N-5A	24 V DC 5 mA 16 inputs Terminal block
	AH32AM10N-5A	24 V DC 5 mA 32 inputs Terminal block
	AH32AM10N-5B	24 V DC 5 mA 32 inputs DB37 connector
	AH32AM10N-5C	24 V DC 5 mA 32 inputs Latch connector
	AH64AM10N-5C	24 V DC 3.2 mA 64 inputs Latch connector
	AH16AM30N-5A	100~240 V AC 4.5 mA~9 mA (100 V, 50 Hz) 16 inputs Terminal block
	AH16AR10N-5A	24 V DC 5 mA 16 inputs Terminal block (I/O interrupts are supported.)
	AH16AN01R-5A	240 V AC/24 V DC 2 A 16 outputs Relay Terminal block
	AH16AN01T-5A	12~24 V DC 0.5 A 16 outputs Sinking output Terminal block

1

Classification	Model Name	Description
Digital input/output module	AH16AN01P-5A	12~24 V DC 0.5 A 16 outputs Sourcing output Terminal block
	AH32AN02T-5A	12~24 V DC 0.1 A 32 outputs Sinking output Terminal block
	AH32AN02T-5B	12~24 V DC 0.1 A 32 outputs Sinking output DB37 connector
	AH32AN02T-5C	12~24 V DC 0.1 A 32 outputs Sinking output Latch connector
	AH32AN02P-5A	12~24 V DC 0.1 A 32 outputs Sourcing output Terminal block
	AH32AN02P-5B	12~24 V DC 0.1 A 32 outputs Sourcing output DB37 connector
	AH32AN02P-5C	12~24 V DC 0.1 A 32 outputs Sourcing output Latch connector
	AH64AN02T-5C	12~24 V DC 0.1 A 64 outputs Sinking output Latch connector
	AH64AN02P-5C	12~24 V DC 0.1 A 64 outputs Sourcing output Latch connector
	AH16AN01S-5A	100~240 V AC 0.5 A 16 outputs TRIAC Terminal block

Classification	Model Name	Description
Digital input/output module	AH16AP11R-5A	24 V DC 5 mA 8 inputs 240 V AC/24 V DC 2 A 8 outputs Relay Terminal block
	AH16AP11T-5A	24 V DC 5 mA 8 inputs 12~24 V DC 0.5 A 8 outputs Sinking output Terminal block
	AH16AP11P-5A	24 V DC 5 mA 8 inputs 12~24 V DC 0.5 A 8 outputs Sourcing output Terminal block
Analog input/output module	AH04AD-5A	Four-channel analog input module Hardware resolution: 16 bits 0/1 V~5 V, -5 V~5 V, 0 V~10 V, -10 V~10 V, 0/4 mA~20 mA, and -20 mA~20 mA Conversion time: 150 us/channel
	AH08AD-5B	Eight-channel analog input module Hardware resolution: 16 bits 0/1 V~5 V, -5 V~5 V, 0 V~10 V, and -10 V~10 V Conversion time: 150 us/channel
	AH08AD-5C	Eight-channel analog input module Hardware resolution: 16 bits 0/4 mA~20 mA, and -20 mA~20 mA Conversion time: 150 us/channel
	AH04DA-5A	Four-channel analog output module Hardware resolution: 16 bits 0/1 V~5 V, -5 V~5 V, 0 V~10 V, -10 V~10 V, and 0/4 mA~20 mA Conversion time: 150 us/channel
	AH08DA-5B	Eight-channel analog output module Hardware resolution: 16 bits 0/1 V~5 V, -5 V~5 V, 0 V~10 V, and -10 V~10 V Conversion time: 150 us/channel
	AH08DA-5C	Eight-channel analog output module Hardware resolution: 16 bits 0/4 mA~20 mA Conversion time: 150 us/channel



Classification	Model Name	Description
Analog input/output module	AH06XA-5A	Four-channel analog input module Hardware resolution: 16 bits 0/1 V~5 V, -5 V~5 V, 0 V~10 V, -10 V~10 V, 0/4 mA~20 mA, and -20 mA~20 mA Conversion time: 150 us/channel Two-channel analog output module Hardware resolution: 16 bits 0/1 V~5 V, -5 V~5 V, 0 V~10 V, -10 V~10 V, and 0/4 mA~20 mA Conversion time: 150 us/channel
	AH04PT-5A	Four-channel four-wire/three-wire RTD Sensor type: Pt100/Pt1000/Ni100/Ni1000 sensor, and 0~300 Ω input impedance Resolution: 0.1°C/0.1°F (16 bits) Four-wire conversion time: 150 ms/channel Three-wire conversion time: 300 ms/channel
Temperature measurement module	AH08PTG-5A	Eight-channel four-wire/three-wire/two-wire RTD Sensor type: Pt100/Pt1000/Ni100/Ni1000, and 0~300 Ω input impedance Resolution: 0.1°C/0.1°F (16 bits) Conversion time: 20 ms/4 channels and 200 ms/8 channels
	AH04TC-5A	Four-channel thermocouple Sensor type: J, K, R, S, T, E, N, and -150~+150 mV Resolution: 0.1°C/0.1°F Conversion time: 200 ms/channel
	AH08TC-5A	Eight-channel thermocouple Sensor type: J, K, R, S, T, E, N, and -150~+150 mV Resolution: 0.1°C/0.1°F Conversion time: 200 ms/channel
Motion control module	AH02HC-5A	Two-channel high-speed counter module (200 kHz)
	AH04HC-5A	Four-channel high-speed counter module (200 kHz)
	AH05PM-5A	Two-axis pulse train motion control module (1 MHz)
	AH10PM-5A	Six-axis pulse train motion control module (Four axes: 1 MHz; Two axes: 200 kHz)
	AH15PM-5A	Four-axis pulse train motion control module (1 MHz)
	AH20MC-5A	Twelve-axis DMCNET (Delta Motion Control Network) motion control module (10 Mbps)
Network module	AH10EN-5A	It is an Ethernet communication module. It can function as a master or a slave. It is equipped with two Ethernet ports, and supports a Modbus TCP master.
	AH10SCM-5A	It is a serial communication module with two RS-485/RS-422 ports, and supports Modbus and UD Link protocols. One part of communication is isolated from the other part of the communication, and one part of power is isolated from the other part of the power.
	AH10DNET-5A	It is a DeviceNet communication module. It can function as a master or a slave. The maximum communication speed is 1 Mbps.
	AH10PFBM-5A	PROFIBUS-DP master module
	AH10PFBS-5A	PROFIBUS-DP slave module
	AH10COPM-5A	It is a CANopen communication module. It can function as a master or a slave.
Remote I/O module	AHRTU-DNET-5A	DeviceNet remote I/O module
	AHRTU-PFBS-5A	PROFIBUS-DP remote I/O module
Extension cable	AHACAB06-5A	0.6 meter extension cable for connecting an extension backplane

Classification	Model Name	Description
Extension cable	AHACAB10-5A	1.0 meter extension cable for connecting an extension backplane
	AHACAB15-5A	1.5 meter extension cable for connecting an extension backplane
	AHACAB30-5A	3.0 meter extension cable for connecting an extension backplane
	AHAADP01EF-5A/ AHAADP02EF-5A	Fiber optics modules for extension backplanes
I/O extension cable	DVPACAB7A10	1.0 meter I/O extension cable (latch connector) for AH32AM10N-5C and AH64AM10N-5C
	DVPACAB7B10	1.0 meter I/O extension cable (latch connector) for AH32AN02T-5C, AH32AN02P-5C, AH64AN02T-5C and AH64AN02P-5C
	DVPACAB7C10	1.0 meter I/O extension cable (DB37 connector) for AH32AM10N-5B, AH32AN02T-5B, and AH32AN02P-5B
	DVPACAB7D10	1.0 meter I/O extension cable for AH04HC-5A and AH20MC-5A
	DVPACAB7E10	1.0 meter I/O extension cable for AH10PM-5A and AH15PM-5A
External terminal module	DVPAETB-ID32A	I/O external terminal module for AH32AM10N-5C and AH64AM10N-5C 32 inputs
	DVPAETB-OR16A	I/O external terminal module for AH32AN02T-5C and AH64AN02T-5C 16 relay outputs
	DVPAETB-OR16B	I/O external terminal module for AH32AN02P-5C and AH64AN02P-5C 16 relay outputs
	DVPAETB-ID32B	I/O external terminal module for AH32AM10N-5B 32 inputs
	DVPAETB-OR32A	I/O external terminal module for AH32AN02T-5B 32 relay outputs
	DVPAETB-OR32B	I/O external terminal module for AH32AN02P-5B 32 relay outputs
	DVPAETB-OT32A	I/O external terminal module for AH32AN02T-5C, AH32AN02P-5C, AH64AN02T-5C, and AH64AN02P-5C 32 transistor outputs
	DVPAETB-OT32B	I/O external terminal module for AH32AN02T-5B and AH32AN02P-5B 32 transistor outputs
	DVPAETB-IO16C	I/O external terminal module for AH04HC-5A and AH20MC-5A
	DVPAETB-IO24C	I/O external terminal module for AH10PM-5A
DVPAETB-IO34C	I/O external terminal module for AH15PM-5A	
Space module	AHASP01-5A	Space module used for an empty I/O slot

1



1.2 Characteristics

AH500 system

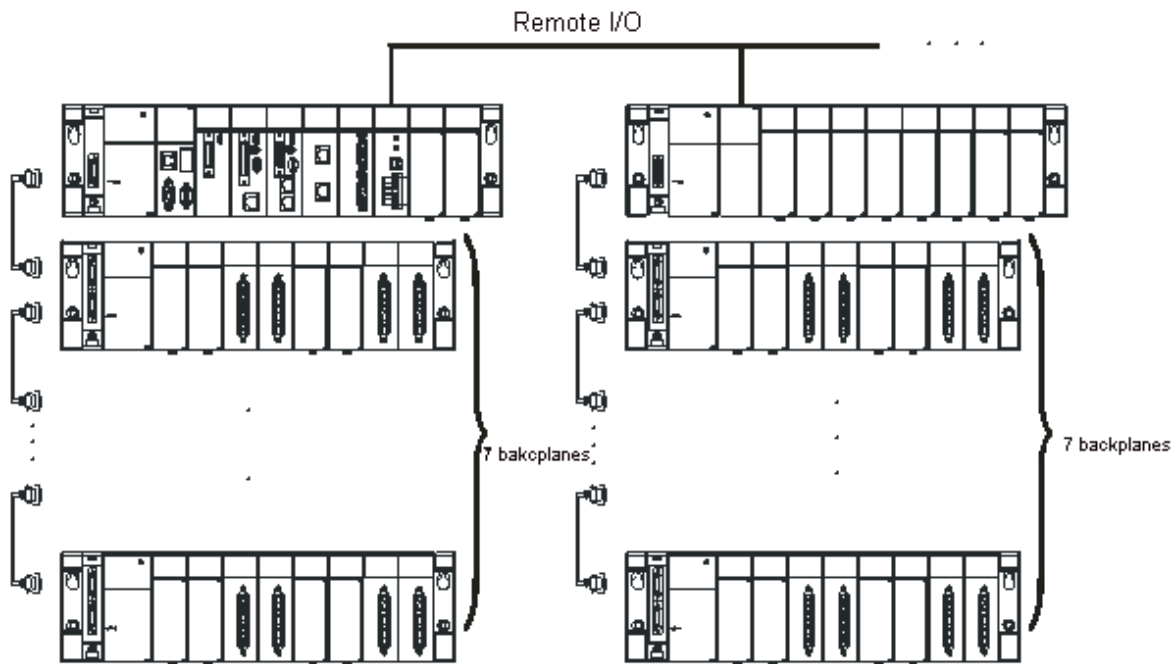

The characteristics of the AH500 series CPU module are as follows.

(1) High efficiency

- The AH500 series CPU module adopts a 32-bit high-speed processor. The instructions are executed at a speed of 0.3 milliseconds per 1K steps. (Fifty percent of the instructions are basic instructions, and fifty percent of the instructions are applied instructions.)

(2) Supporting more inputs and outputs

- The AH500 series CPU module supports up to 4,352 local digital I/O or 512 analog I/O.
- A complete AH500 system consists of eight backplanes at most, including a main backplane. Eight I/O modules at most can be installed on a backplane. Therefore, for the AH500 series CPU, 64 digital input/output modules at most or 64 analog input/output modules at most can be installed.
- Eight remote I/O modules at most can be installed on a main backplane. 128,000 remote digital inputs/outputs, or 4,000 remote analog inputs/outputs at most are supported.

(3) Multiple I/O modules

- The I/O modules supported by the AH500 series CPU module are digital input/output modules, analog input/output modules, temperature measurement modules, network modules, motion control modules, and remote I/O modules.

Module	Description
Digital input/output module	Digital input/output AH16AM10N-5A, AH32AM10N-5A, AH32AM10N-5B, AH32AM10N-5C, AH64AM10N-5C, AH16AM30N-5A, AH16AN01R-5A, AH16AN01T-5A, AH16AN01P-5A, AH32AN02T-5A, AH32AN02T-5B, AH32AN02T-5C, AH32AN02P-5A, AH32AN02P-5B, AH32AN02P-5C, AH64AN02T-5C, AH64AN02P-5C, AH16AN01S-5A, AH16AP11R-5A, AH16AP11T-5A, AH16AP11P-5A. and AH16AR10N-5A
Analog input/output module	Analog input/output AH04AD-5A, AH08AD-5B, AH08AD-5C, AH04DA-5A, AH08DA-5B, AH08DA-5C, and AH06XA-5A

Module	Description
Temperature measurement module	Measuring the temperature AH04PT-5A, AH08PTG-5A, AH04TC-5A, and AH08TC-5A
Motion control module	Controlling the motion AH02HC-5A, AH04HC-5A, AH05PM-5A, AH10PM-5A, AH15PM-5A, and AH20MC-5A
Network module	Extending the communication interface (*There are multiple interfaces. All network modules can be installed on the main backplane except AH10SCM-5A.) AH10EN-5A, AH10SCM-5A, AH10DNET-5A, AH10PFBS-5A, AH10PFBM-5A, and AH10COPM-5A
Remote I/O module	It is installed on the main backplane as a remote terminal unit. (*It supports multiple communication interfaces.) AHRTU-DNET-5A and AHRTU-PFBS-5A

(4) **Larger program capacity and memory**

- The program capacity of the AH500 series CPU modules can be up to 256K steps. Users do not need to use a more advanced CPU if the program capacity becomes large.
- The AH500 series CPU module has 64K words of memory. Besides, users can declare up to 1024 function blocks.

(5) **Supporting IEC 61131-3**

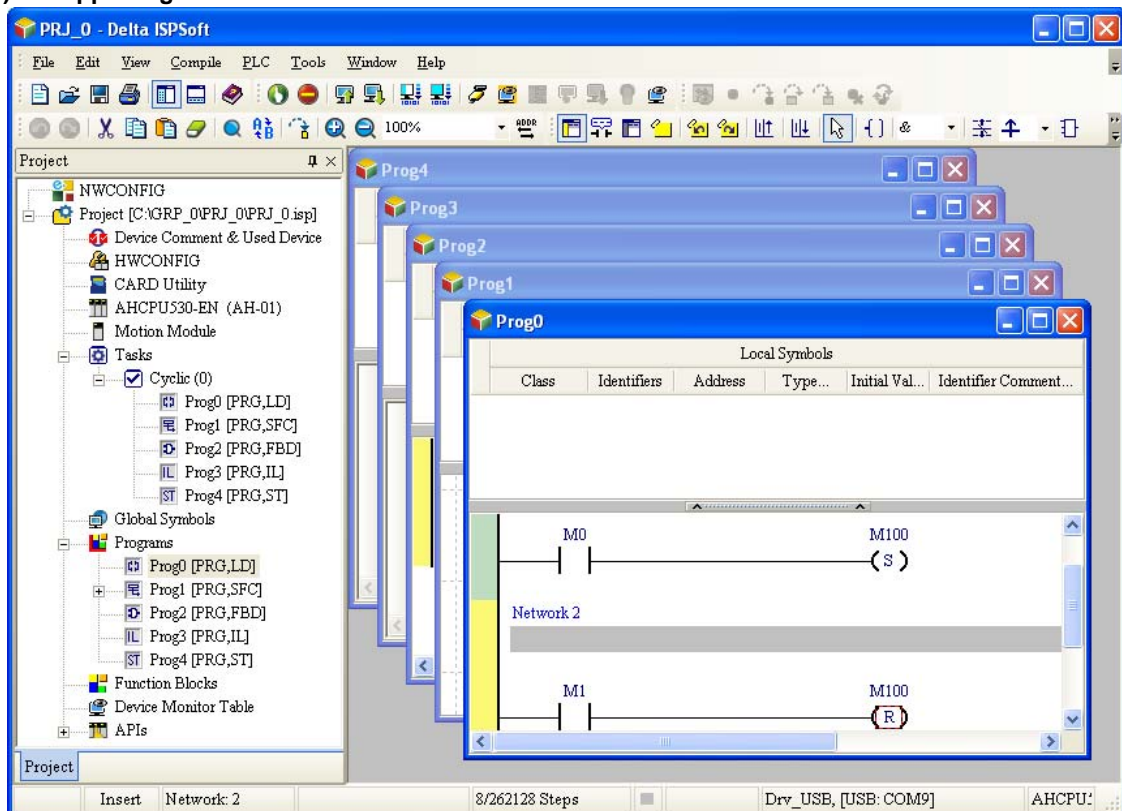

- The AH500 series CPU module supports IEC 61131-3.

1

- The programming languages which are supported are instruction lists (IL), structured texts (ST), ladder diagrams (LD), sequential function charts (SFC), and function block diagrams (FBD).

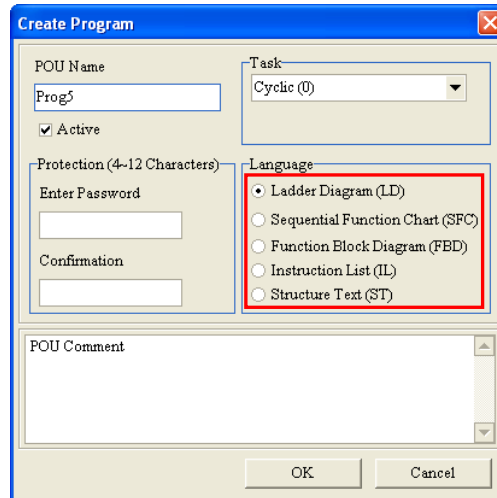

- Users can select a programming language according to their preference and the convenience. The programming languages support one another so that the programs written by different users are related.

(6) Strong function block

- Not only the standard IEC61131-3 function blocks are supported, but also the convenient function blocks provided by Delta Electronics, Inc. are supported. Users can write the program frequently executed in a function block so that the program becomes more structured and can be executed more conveniently.
- The symbol for a function block in a ladder diagram is like an Integrated circuit (IC) in a circuit diagram. Owing to the fact that the ladder diagram is based on the traditional circuit diagram, the operation of a function block is quite similar to the function of an integrated circuit. Users only need to send the signal to the corresponding input of the function block, and they can receive the signal or state which is required. During the whole process, users do not need to consider the processing procedure inside the function block.

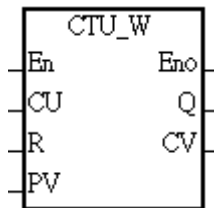

- A function block is a program element equipped with the operation function. It is similar to a subroutine, and is a type of POU (Program Organization Unit). It can not operate by itself, and has to be called through the program POU. After the related parameters are transmitted, the function defined by a function block is executed. Besides, the final operation result can be sent to the device or variable used in the superior POU after the execution of the function block is complete.
- The setting of passwords by means of ISPSOft provides the secrecy of function blocks for special businesses. The program inside a function block can not be learned, and the patent of a business will not be infringed.

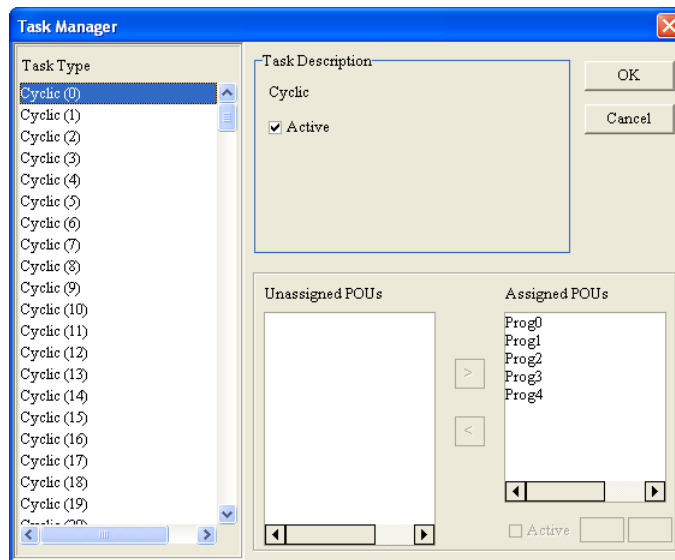
(7) Task

1

- The programs can be assigned to 283 tasks at most. Among the 288 tasks, 32 tasks are cyclic tasks, 32 tasks are I/O interrupts, 4 tasks are timer interrupts, 2 tasks are communication interrupts, 1 task is an external 24 V low-voltage interrupt, and 212 tasks are user-defined tasks.
 - Users can enable and disable a task during the execution of a program by means of TKON and TKOFF.
- (8) Increasing the efficiency of configuring the hardware through an USB cable and ISPSOft**
- The AH500 series CPU module provides a standard USB 2.0 interface. USB 2.0 increases the data transfer rate, and decreases the time it takes to download the program, monitor the program and configure the hardware. Besides, users do not need to buy a communication cable for the CPU module. They can use a general USB cable to connect to the AH500 series CPU module.
- (9) Serial control interface with multiple functions**

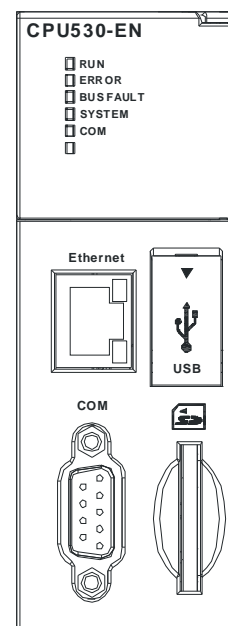
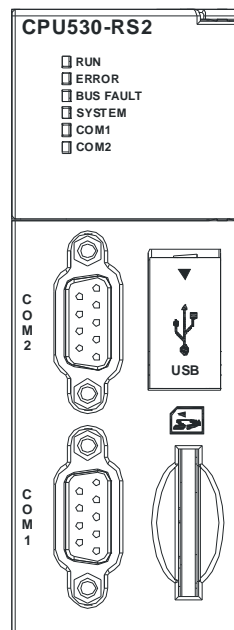

- AHCPU500/510/520/530-RS2 provides two DB9 serial control interfaces, i.e. COM1 and COM2.
- AHCPU500/510/520/530-EN provides one DB9 serial control interface, i.e. COM.
- Users can set the DB9 serial control interface to RS232, RS485, or RS422 according to the application environment. The data transfer rate can be increased from 9600 bps to 1 Mbps.

1

- After users set the PLC Link in ISPSOft, they can exchange the data with a device on the RS-485 network through the RS-485 serial control interface, and do not need to write any program.

(10) High-speed Ethernet communication interface

- AHCPU500/510/520/530-EN is equipped with a 10/100 M Ethernet communication interface, and supports emails, webs, and socket services.
- After users set the Ether Link in ISPSOft, they can exchange the data with a device in the Ethernet network through the Ethernet communication interface, and do not need to write any program.
- The status or the error message related to the system is sent to users' email boxes immediately. Users do not need to be on the spot to understand the problem.

(11) Memory card

- The memory card has the following functions.
 System backup: The user program, the CPU parameters, the module table, the setting value in the device
 System recovery: The user program, the CPU parameters, the module table, and the setting value in the device
 Parameter storage: The value in the device
 Log storage: The system error log and the system status log

(12) Hot swap

- The AH500 series I/O modules support the on-line uninterruptible hot swap. When the system runs, users can replace the module which breaks down without disconnecting the module. After the module is replaced, the new module runs normally. Users do not need to set the module manually or switch the state.

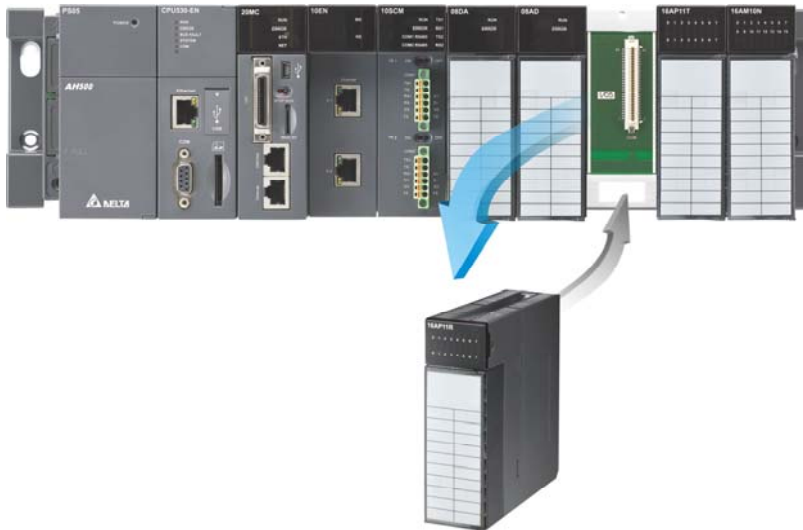

(13) Supporting the on-line debugging mode

- After a single instruction step has been complete, or after a breakpoint is specified, users can easily find the bug in the program by means of the on-line debugging mode supported by the AH500 series CPU module.
- If users want to enter the debugging mode, the CPU module must run. After users enable the on-line monitoring function, they have to click . The debugging screen varies from programming language to programming language, but the same operation applies to these programming languages. For the AH500 series PLC, structured texts do not support the debugging mode, and sequential function charts support the debugging mode during the action and the transition.

Step 1: Setting the PLC to RUN

1

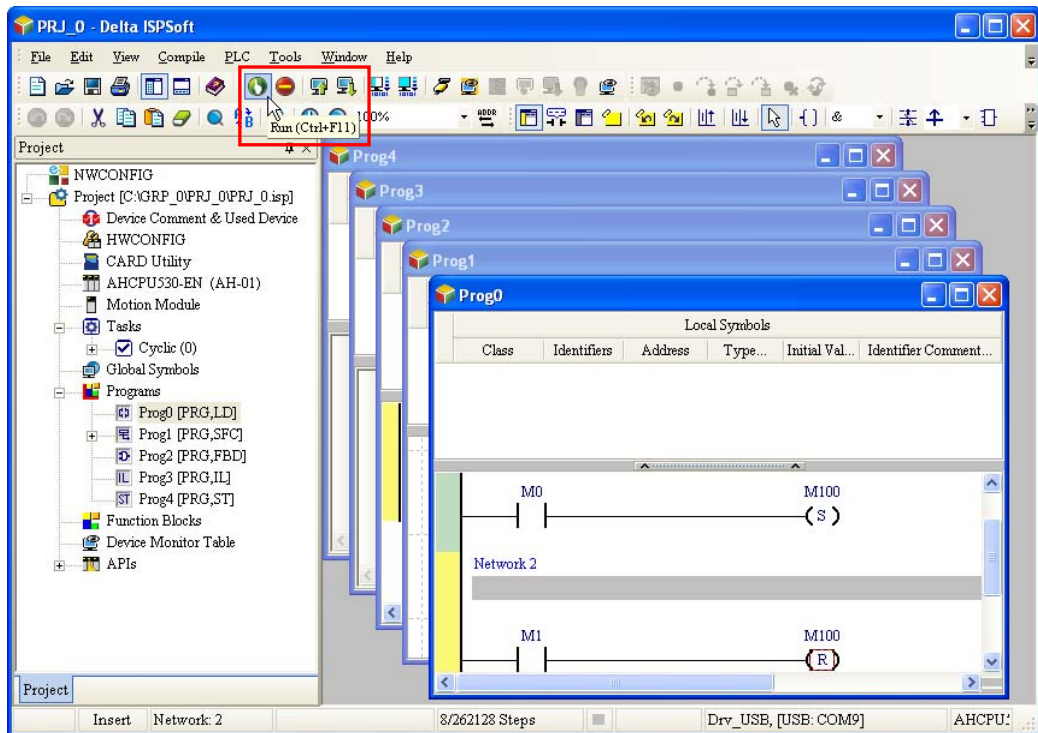

Step 2: Entering the on-line mode

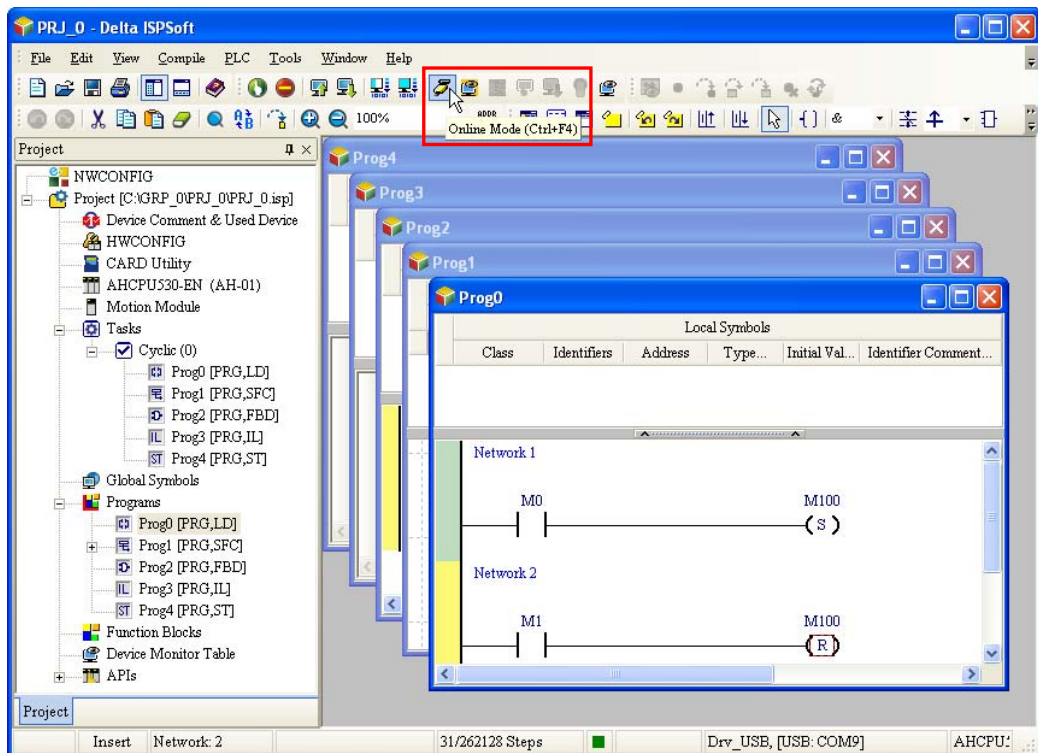

Step 3: Entering the debugging mode

1

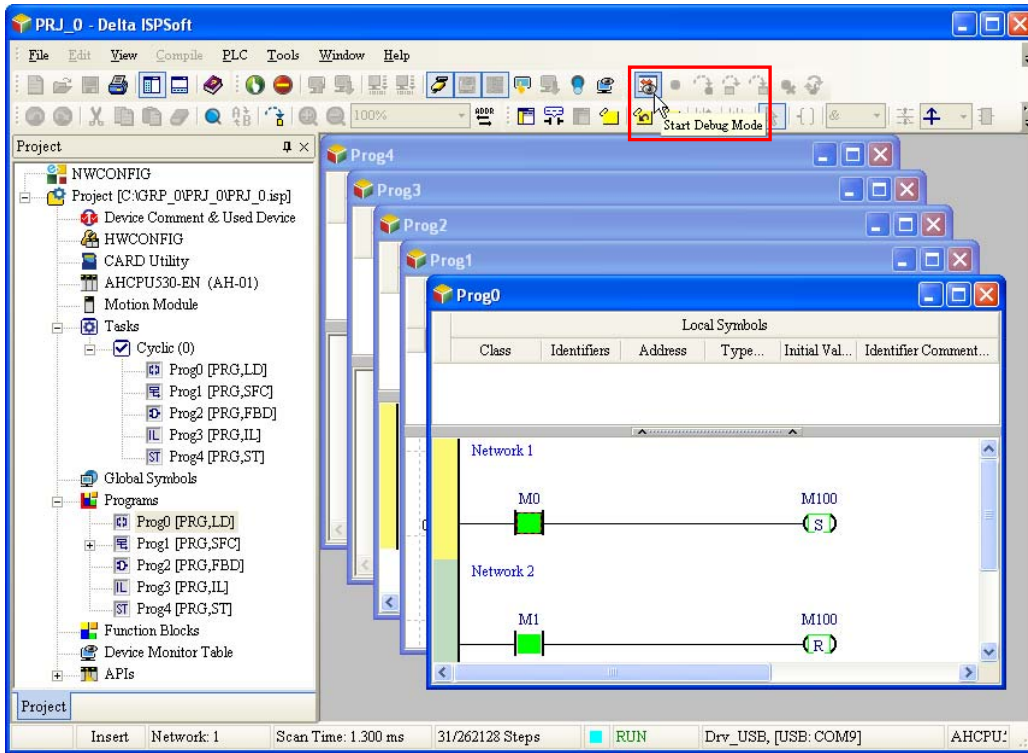

(14) Supporting the on-line editing mode

- When the system runs, users can make use of the on-line editing mode to update the program without affecting the operation of the system.
- When the system is in the on-line monitoring mode, users can enter the on-line editing mode by clicking .

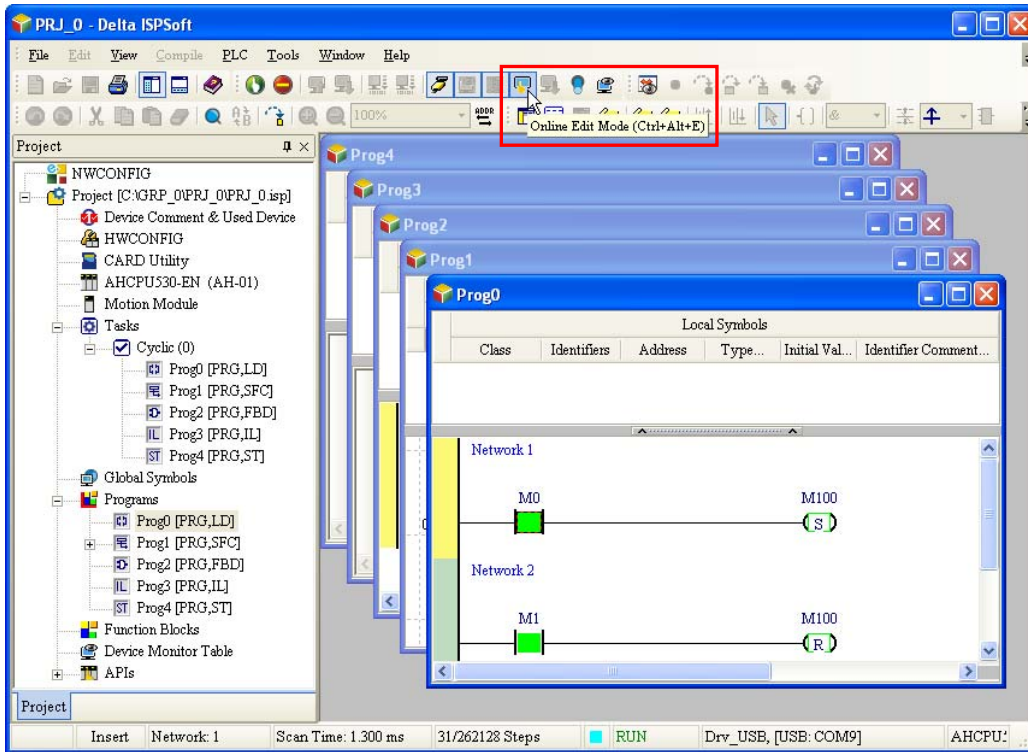

- After the program is modified and compiled, users can update the program in the CPU module by clicking .

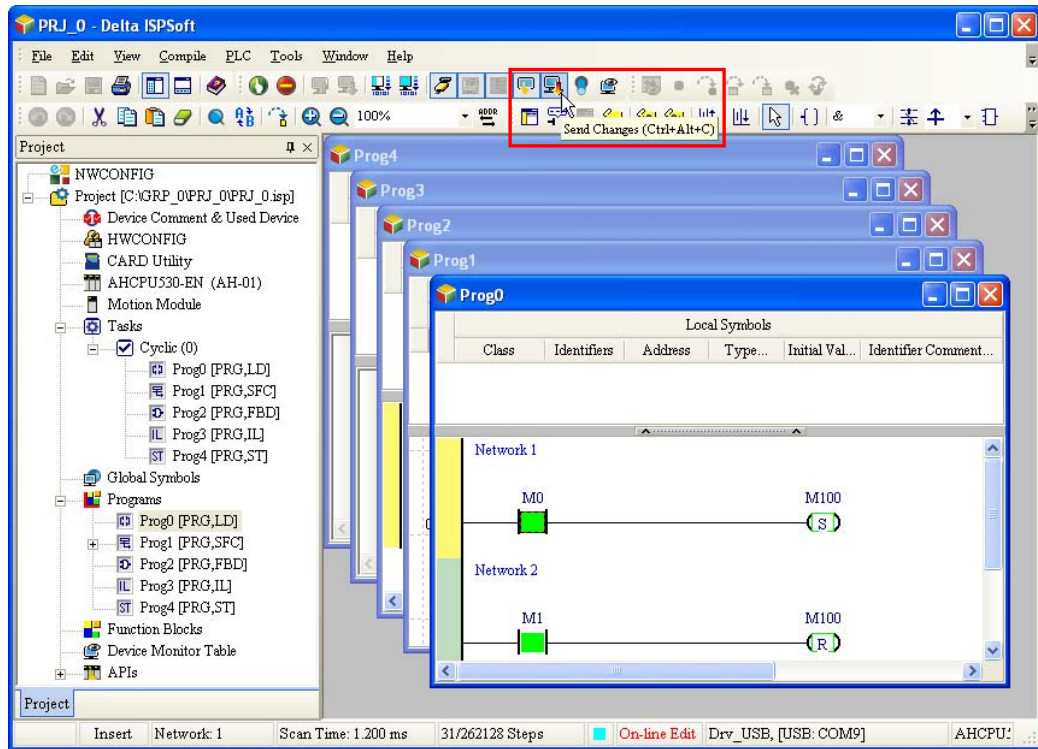

MEMO



2

Chapter 2 Installing Hardware

Table of Contents

2.1	AH500 Hardware Framework.....	2-2
2.1.1	Component Parts of AH500 Hardware.....	2-2
2.1.1.1	Necessary Components	2-2
2.1.1.2	Accessories	2-4
2.1.2	Installing Modules on a Main Backplane	2-8
2.1.3	Installing Modules on an Extension Backplane	2-9
2.1.4	Connecting a Main Backplane to an Extension Backplane	2-9
2.2	Warning	2-9
2.3	Installation	2-10
2.3.1	Installation of Modules in a Control Box	2-10
2.3.2	Mounting a Backplane	2-10
2.3.3	Installing a Module.....	2-13
2.3.4	Installing a Removable Terminal Block.....	2-14
2.3.5	Installing a Wiring Module	2-15
2.3.6	Connecting Backplanes.....	2-16
2.3.7	Connecting a Communication Cable	2-18

2.1 AH500 Hardware Framework

2.1.1 Component Parts of AH500 Hardware

A complete AH500 system consists of a main backplane, extension backplanes, power supply modules, a CPU module, I/O modules, and extension cables. The basic AH500 system is illustrated below.

2

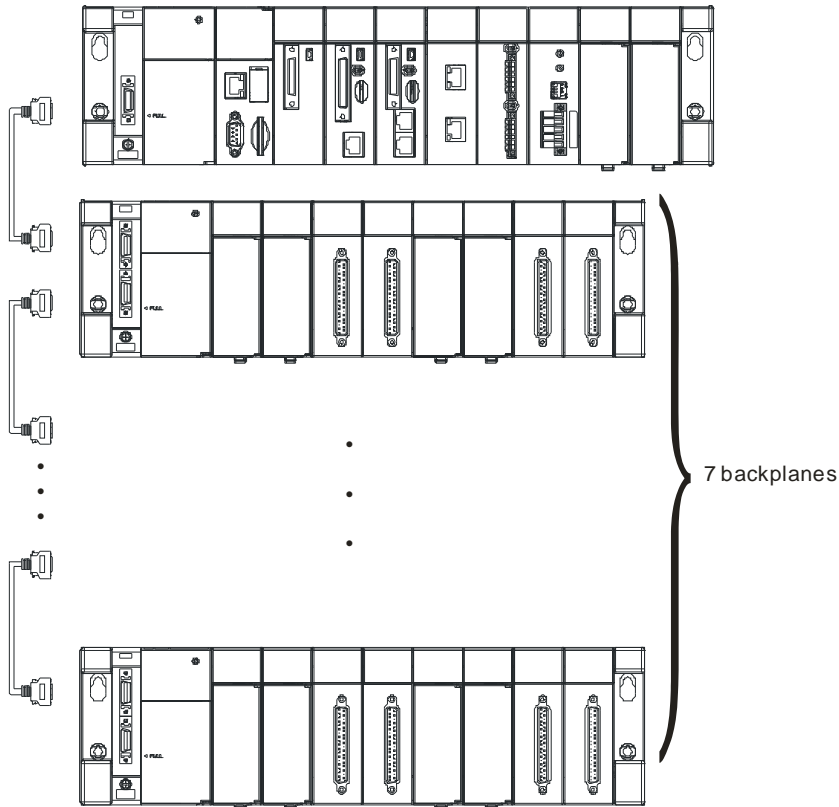

2.1.1.1 Necessary Components

A complete AH500 system consists of the following four necessary components.

- **Main backplane**

A CPU module and other modules are installed on a main backplane which provides the function of connecting buses. The main backplanes are divided into four types according to the number of I/O modules installed on the main backplanes. These four types are four-slot main backplanes, six-slot main backplanes, eight-slot main backplanes, and twelve-slot main backplanes. Besides, a CPU module installed on a main backplane can be replaced by a RTU module on a control network. Please notice that there is at least one CPU module on a control network.

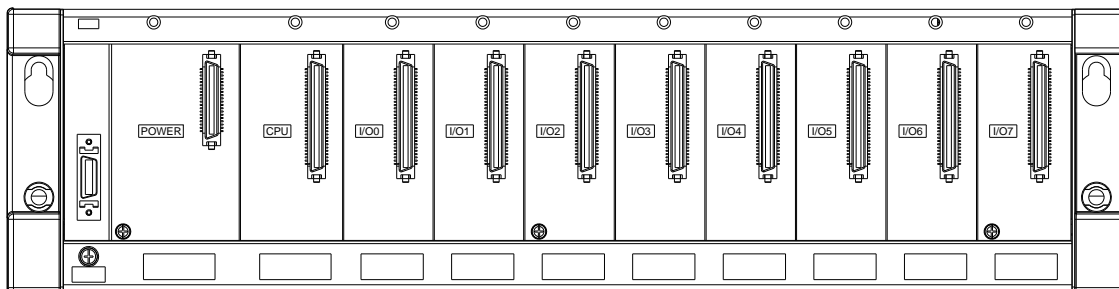

● **Power supply module**

A power supply module functions to convert alternating current to direct current, or directly provides direct current. It provides power for the modules installed on it. A backplane must be assigned a power supply module whether it is a main backplane or an extension backplane. A power supply module has to be installed on the left-most side of a backplane.

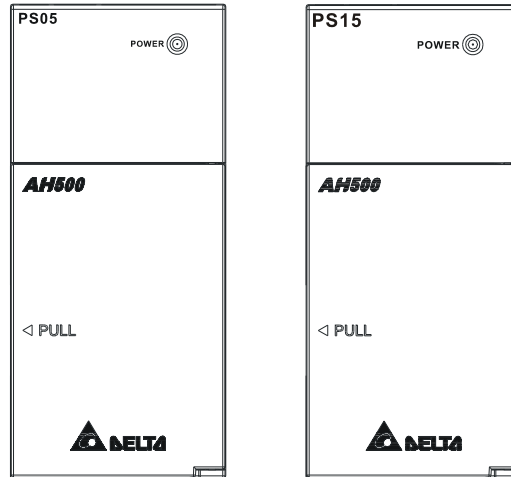

● **CPU module**

A CPU module is the nucleus of a complete AH500 system. It is responsible for controlling and managing the whole system, and is installed in the second slot from the left on the main backplane. Besides, Delta Electronics, Inc. provides businesses with several types of CPU modules. Users can select a CPU module according to their needs.

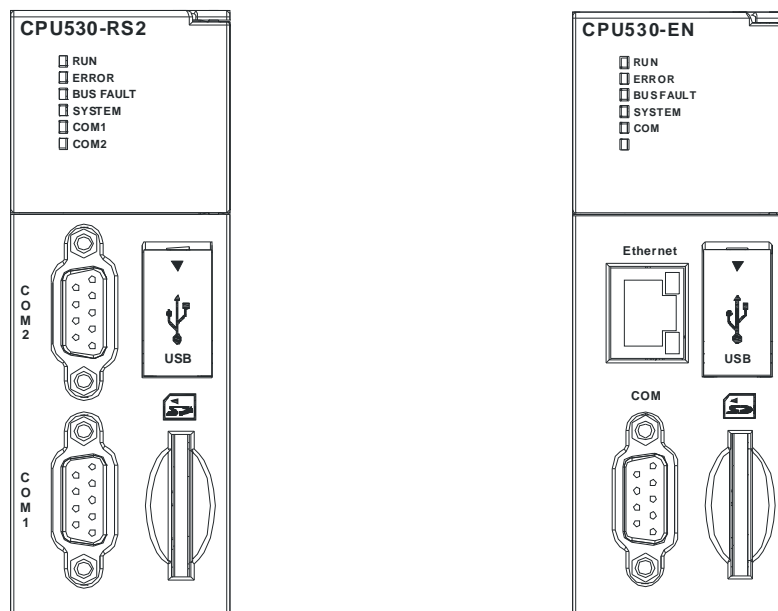

2

● **Communication cable**

Several communication interfaces are built in a CPU module, and users are provided with many types of network modules. Users can select a suitable Communication cable according to the actual situation. Please refer to the following table for information about the communication interfaces and the main applications. The specifications for the interface on an extension backplane are defined by Delta Electronics, Inc. itself. The interface is used to connect the backplanes, and users need to use a Delta extension cable.

Interface	Connector	Application
Communication port	DB9	Computer/HMI communication/Industrial control network (RS-232/422/485)
Ethernet	RJ45	Computer/HMI communication/Remote control/Data exchange/Industrial control network
USB	Mini USB	Computer communication
DeviceNet	DeviceNet	Industrial control network The maximum data transmission rate is 1 Mbps.
Interface on an extension backplane	Delta connector	Extension cable for a complete AH500 system

2.1.1.2 Accessories

The following are the accessories for an AH500 system. Users can select them according to their needs.

● **Extension module**

Apart from the standard communication ports on a CPU module, the CPU module does not equipped with other I/O functions. If users want to use I/O functions, they can select suitable modules according to the actual situation. The modules which can be used with an AH500 system are listed in the table below.

Digital input/output modules:

AH16AM10N-5A	24 V DC 5 mA 16 inputs Terminal block
AH32AM10N-5A	24 V DC 5 mA 32 inputs Terminal block
AH32AM10N-5B	24 V DC 5 mA 32 inputs DB37 connector
AH32AM10N-5C	24 V DC 5 mA 32 inputs Latch connector
AH64AM10N-5C	24 V DC 3.2 mA 64 inputs Latch connector
AH16AM30N-5A	100~240 V AC 4.5 mA/9 mA (100 V, 50 Hz) 16 inputs Terminal block
AH16AR10N-5A	24 V DC 5 mA 16 inputs Terminal block (I/O interrupts are supported.)

AH16AN01R-5A	240 V AC/24 V DC 2 A 16 outputs Relay Terminal block
AH16AN01T-5A	12~24 V DC 0.5 A 16 outputs Sinking output Terminal block
AH16AN01P-5A	12~24 V DC 0.5 A 16 outputs Sourcing output Terminal block
AH16AN01S-5A	110/220 V AC 0.5 A 16 outputs TRIAC Terminal block
AH32AN02T-5A	12~24 V DC 0.1 A 32 outputs Sinking output Terminal block
AH32AN02T-5B	12~24 V DC 0.1 A 32 outputs Sinking output DB37 connector
AH32AN02T-5C	12~24 V DC 0.1 A 32 outputs Sinking output Latch connector
AH32AN02P-5A	12~24 V DC 0.1 A 32 outputs Sourcing output Terminal block
AH32AN02P-5B	12~24 V DC 0.1 A 32 outputs Sourcing output DB37 connector
AH32AN02P-5C	12~24 V DC 0.1 A 32 outputs Sourcing output Latch connector
AH64AN02T-5C	12~24 V DC 0.1 A 64 outputs Sinking output Latch connector

2

AH64AN02P-5C	12~24 V DC 0.1 A 64 outputs Sourcing output Latch connector
AH16AP11R-5A	24 V DC 5 mA 8 inputs 240 V AC/24 V DC 2 A 8 outputs Relay Terminal block
AH16AP11T-5A	24 V DC 5 mA 8 inputs 12~24 V DC 0.5 A 8 outputs Sinking output Terminal block
AH16AP11P-5A	24 V DC 5 mA 8 inputs 12~24 V DC 0.5 A 8 outputs Sourcing output Terminal block

Analog input/output modules:

AH04AD-5A	Four-channel analog input module 16-bit resolution -10~+10 V, 0~10 V, -5~+5 V, 0/1~5 V, 0/4~20 mA, and -20~+20 mA
AH08AD-5B	Eight-channel analog input module 16-bit resolution -10~+10 V, 0~10 V, -5~+5 V, 0/1~5 V
AH08AD-5C	Eight-channel analog input module 16-bit resolution 0/4~20 mA and -20~+20 mA
AH04DA-5A	Four-channel analog output module 16-bit resolution -10~+10 V, 0~10 V, -5~+5 V, 0/1~5 V, and 0/4~20 mA
AH08DA-5B	Eight-channel analog output module 16-bit resolution -10~+10 V, 0~10 V, -5~+5 V, and 0/1~5 V
AH08DA-5C	Eight-channel analog output module 16-bit resolution 0/4~20 mA
AH06XA-5A	Four-channel analog input module 16-bit resolution -10~+10 V, 0~10 V, -5~+5 V, 0/1~5 V, 0/4~20 mA, and -20~+20 mA Two-channel analog output module 16-bit resolution -10~+10 V, 0~10 V, -5~+5 V, 0/1~5 V, and 0/4~20 mA

Temperature measurement modules:

AH04PT-5A	Four-channel four-wire/three-wire RTD Sensor type: Pt100, Pt1000, Ni100, Ni1000, and 0~300 Ω input impedance
AH08PTG-5A	Eight-channel four-wire/three-wire/two-wire RTD Sensor type: Pt100, Pt1000, Ni100, Ni1000, and 0~300 Ω input impedance
AH04TC-5A	Four-channel thermocouple Sensor type: J, K, R, S, T, E, N, and -150~+150 mV
AH08TC-5A	Eight-channel thermocouple Sensor type: J, K, R, S, T, E, N, and -150~+150 mV

Network modules:

AH10EN-5A	It is an Ethernet communication module. It can function as a master or a slave. It is equipped with two Ethernet ports, and supports a Modbus TCP master.
AH10SCM-5A	It is a serial communication module with two RS-485/RS-422 ports, and supports Modbus and UD Link protocols. One part of communication is isolated from the other part of the communication, and one part of power is isolated from the other part of the power.
AH10DNET-5A	It is a DeviceNet communication module. It can function as a master or a slave. The maximum communication speed is 1 Mbps.
AH10PFBM-5A	PROFIBUS-DP master module
AH10PFBS-5A	PROFIBUS-DP slave module
AH10COPM-5A	It is a CANopen communication module. It can function as a master or a slave.

Motion control modules:

AH02HC-5A	Two-channel high-speed counter module (200 kHz)
AH04HC-5A	Four-channel high-speed counter module (200 kHz)
AH05PM-5A	Two-axis pulse train motion control module (1 MHz)
AH10PM-5A	Six-axis pulse train motion control module (Four axes: 1 MHz; Two axes: 200 kHz)
AH15PM-5A	Four-axis pulse train motion control module (1 MHz)
AH20MC-5A	Twelve-axis DMCNET (Delta Motion Control Network) motion control module (10 Mbps)

Remote I/O modules:

AHRTU-DNET-5A	DeviceNet remote I/O module
AHRTU-PFBS-5A	PROFIBUS-DP remote I/O module

Space module:

AHASP01-5A	Space module used for an empty I/O slot
-------------------	---

2

● **Extension backplane**

If the number of slots on the main backplane is not sufficient for the whole system, users can use the extension backplanes to increase the number of extension modules. The extension backplanes are divided into two types according to the number of extension modules installed on the extension backplanes. These two types are six-slot extension backplanes, and eight-slot extension backplanes.

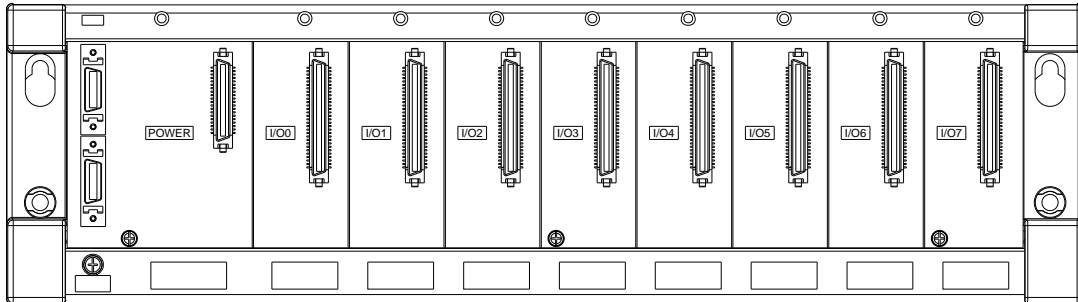

2.1.2 Installing Modules on a Main Backplane

For a main backplane as a master, the first slot from the left is for a power supply module, the second slot is for a CPU module, and the slots following the second slot are for extension modules. All AH500 series extension modules can be installed on a main backplane. Eight AH500 series network modules at most can be installed on a main backplane, but no limits are imposed on the number of other modules which can be installed on a main backplane. No limits are imposed on the installing of modules except that a power supply module and a CPU module have to be installed in the first slot and the second slot respectively. Therefore, users can configure the hardware by themselves. Besides, twelve extension modules at most can be installed on a main backplane.

For a main backplane as a RTU, the second slot is for a RTU module, and only digital input/output modules, analog input/output modules, temperature measurement modules and AH10SCM-5A are supported.

● **Main backplane as a master**

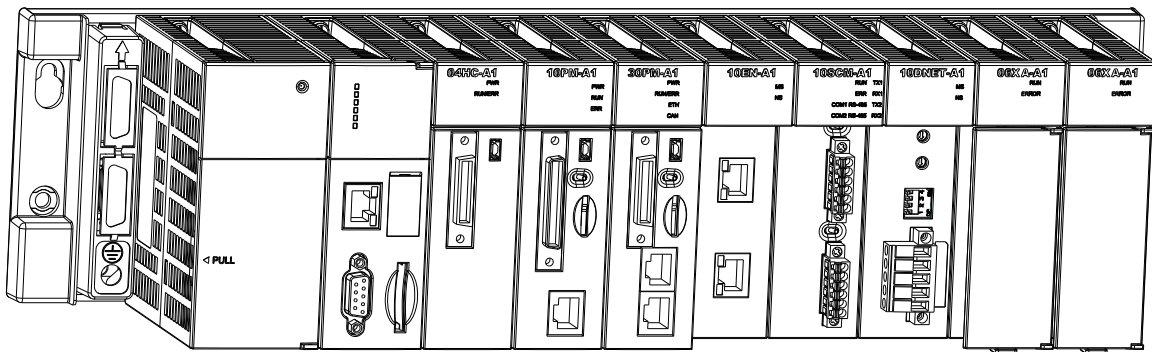

● **Main backplane as a RTU**

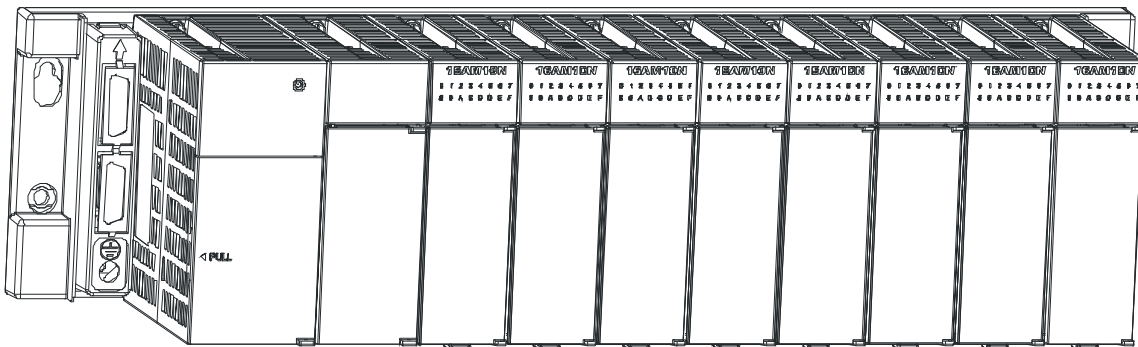

2.1.3 Installing Modules on an Extension Backplane

For an extension backplane, the first slot from the left is for a power supply module, and the slots following the first slot are for extension modules. Only digital input/output modules, analog input/output modules, temperature measurement modules, and AH10SCM-5A can be installed on an extension backplane. Besides, users do not need to arrange the extension modules in a specific order.

- **Extension backplane**

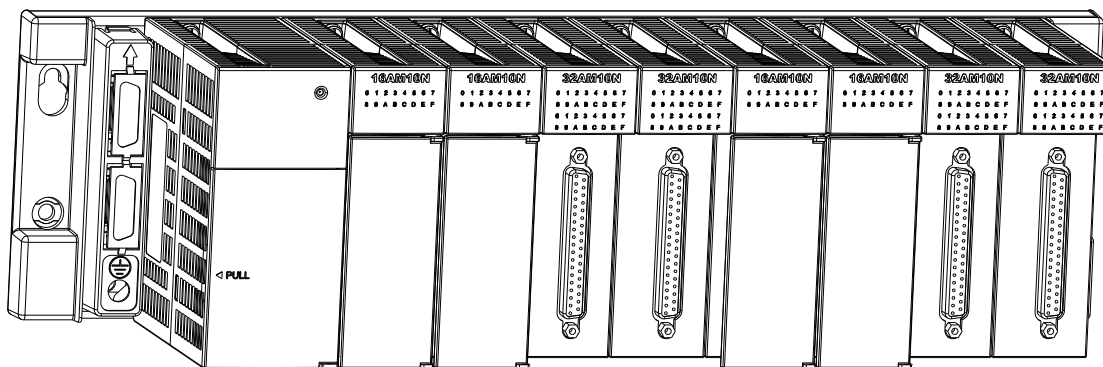

2

2.1.4 Connecting a Main Backplane to an Extension Backplane

A main backplane can be connected to an extension backplane through the interface on the left side of the main backplane, the interface on the left side of the extension backplane, and a Delta extension cable. For a CPU module or a RTU, a main backplane can be connected to seven extension backplanes at most through the interfaces on the backplanes. Therefore, if there is a CPU module and there are several RTUs, not only the CPU module can be connected to seven extension backplanes, but also every RTU can connect to seven extension backplanes.

There are two ports on an extension backplane. The upper port is used to connect to a superior backplane, and the lower port is used to connect to an inferior backplane.

2.2 Warning

- An AH500 system only supports the horizontal installation, and a power supply module has to be installed on the left-most side of a backplane.
- Before a module is installed, please make sure of the size of the module and that of a backplane. To prevent the misestimate from resulting in insufficient installation space, the size of the connector of a communication cable, and the room which needs to be reserved have to be taken into account.
- Please make sure that the work environment conforms to the specifications for the products. It is necessary to take account of the basic temperature/humidity control and the dust/corrosion prevention.
- The electromagnetic interference will result in the wrong action of the whole system. Therefore, users have to do EMC design carefully. Please refer to chapter seven in this manual for more information related to EMC standards.
- If the specifications for the components such as screws and washers are noted specifically in the manual, please use the components conforming to the specifications.
- If a cable is connected to a communication port, please make sure that the connector of the cable is joined to the port on the module properly.
- A backplane has to be mounted on a plane stably instead of being just set on the plane. After it is installed, please make sure that it is fixed on the plane.

2.3 Installation

2.3.1 Installation of Modules in a Control Box

A PLC has to be installed in a closed control box. In order to ensure that the PLC radiates heat normally, the space between the PLC and the control box has to be larger than 50 millimeters.

2

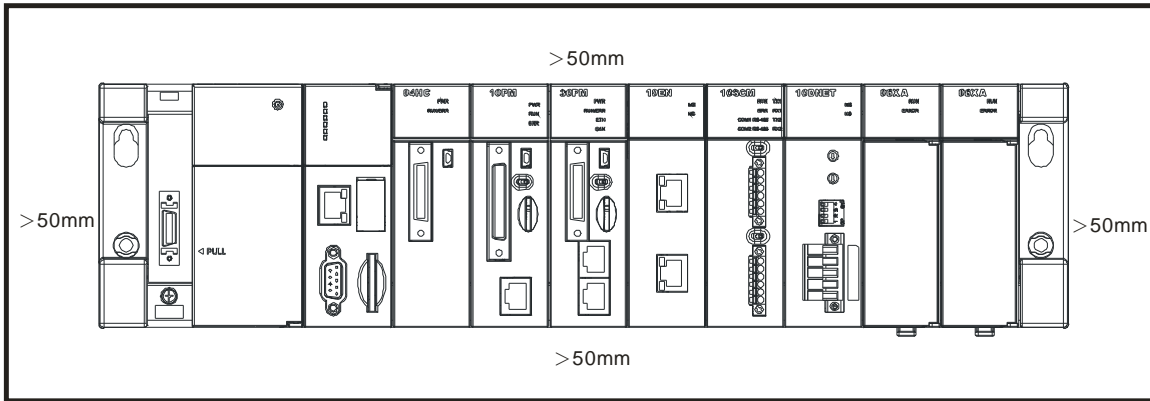

- Please keep the PLC away from high-voltage equipment, high-voltage wires, and high-voltage motors.
- In order to prevent the temperature of a PLC from rising, please do not install the PLC vertically on the bottom/top in the control box.
- Please install a PLC horizontally in the control box, as shown above.
- If users intend to increase the number of modules, they have to leave some space for installing the modules in the control box.

2.3.2 Mounting a Backplane

● Fixing a backplane by screws

Please mount a backplane on a plane by means of M5 screws, as illustrated below. To fix the backplane, users need to judge the length of a screw, the size of a thread, and whether to use a nut according to the actual condition of the plane unless there are specific specifications for a screw which are indicated in the pictures below.

1. Tighten the M5 screws in the holes indicated by a.

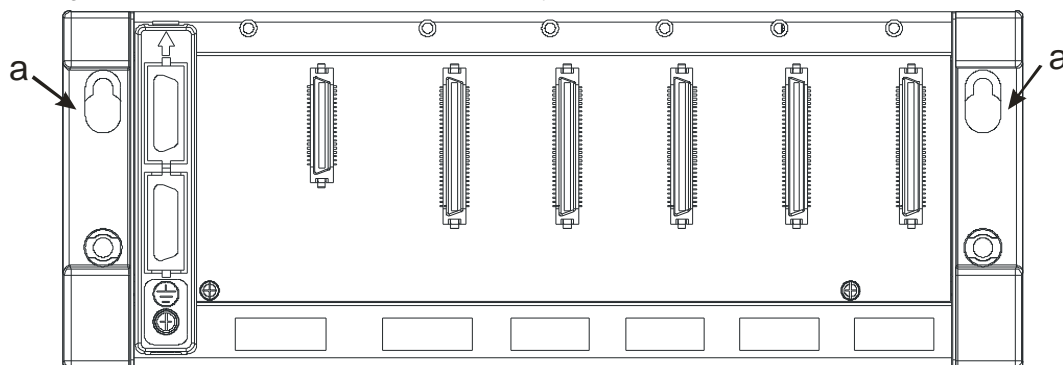

2. Tighten the two screws in the holes indicated by **b**.

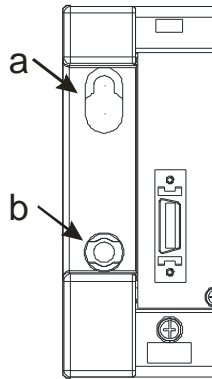

2

- **Installing a DIN rail**

1. The installation is applicable to a 35 millimeter DIN rail.
2. Install the mounting clips on a backplane.

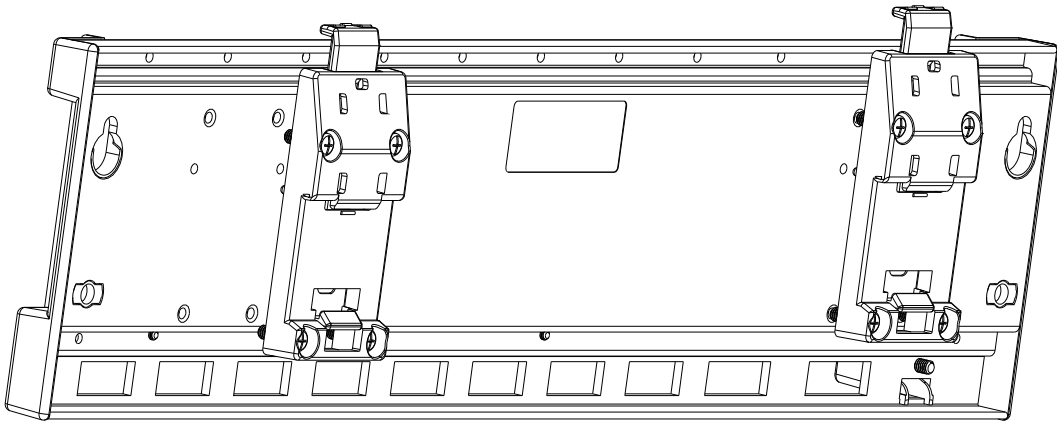

3. Install the backplane on a DIN rail.
Step 1: Pull the clasp in the direction indicated by the arrow.
Step 2: Hang the backplane on a DIN rail.
Step 3: Press the clasp.

2

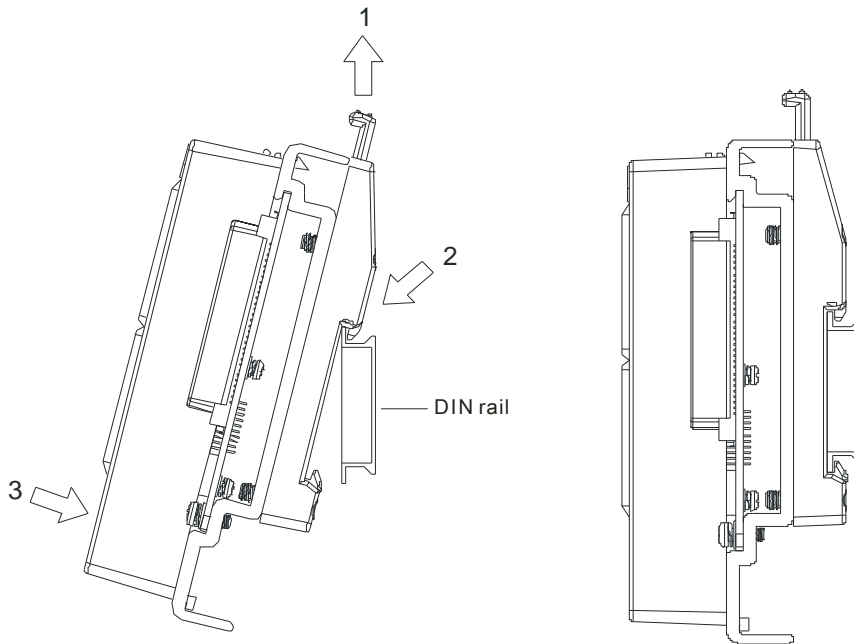

● **Removing a DIN rail**

- Step 1: Press the clasp in the direction indicated by the arrow.
- Step 2: Remove the backplane.

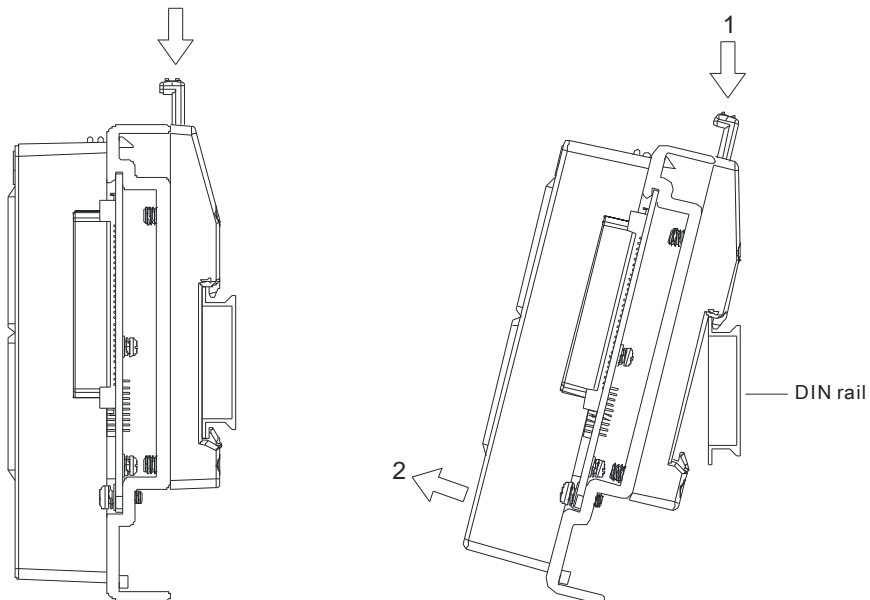

2.3.3 Installing a Module

Insert a module into a slot, make sure that the module is installed on the backplane properly, and tighten the the screw, as illustrated below.

1. Insert the projection under the module into the hole in the backplane.
2. Push the module in the direction indicated by the arrow until it clicks.

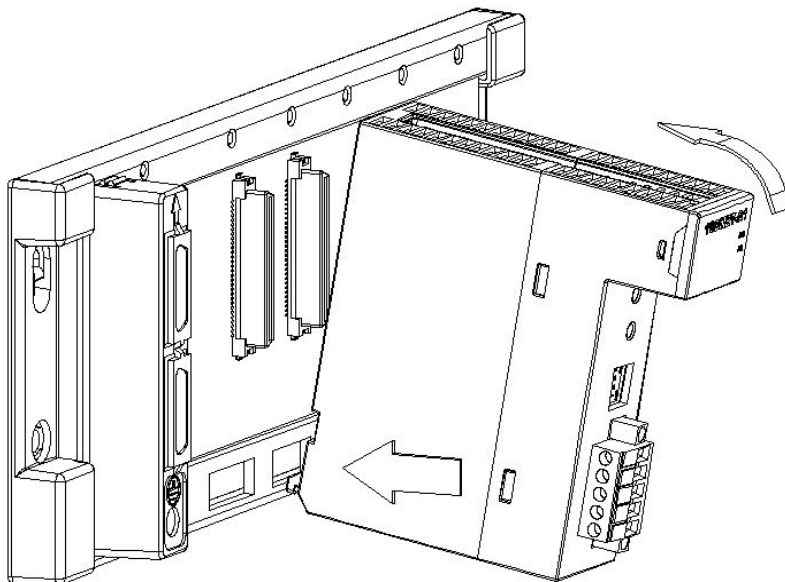

3. Tighten the screw on the module.

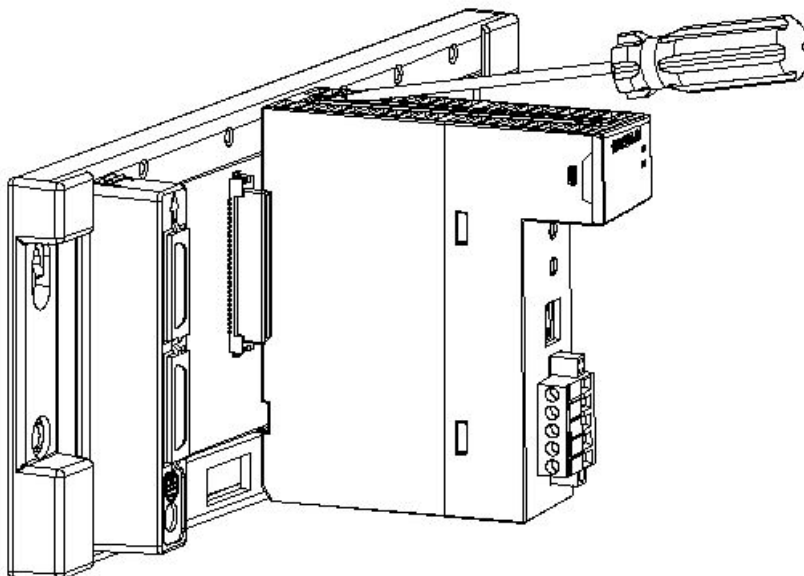

2.3.4 Installing a Removable Terminal Block

- **Installation**

1. Level a terminal block at the printed circuit board, and press it into the module.

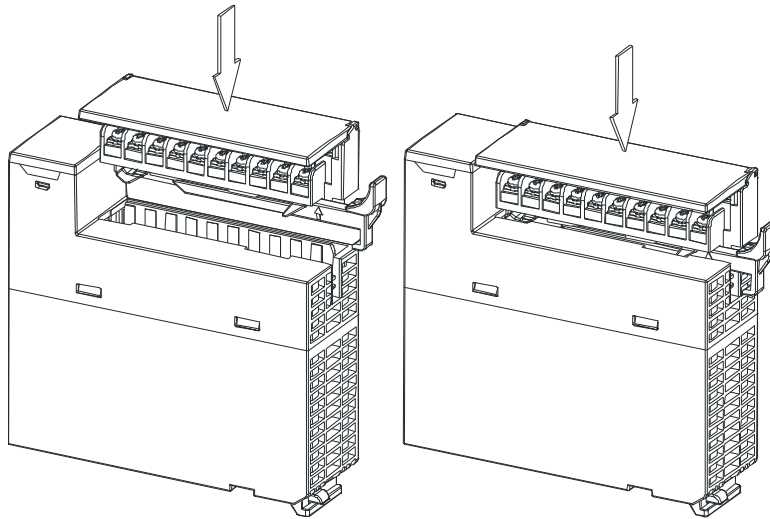

2. Press the clip in the direction indicated by the arrow.

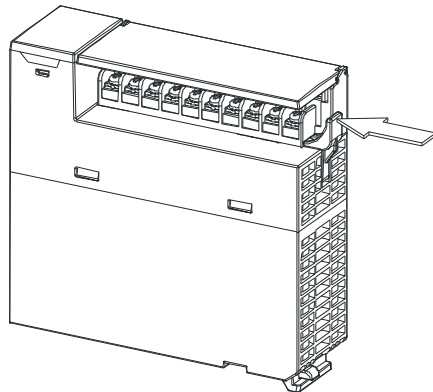

- **Removal**

1. Pull the clip in the direction indicated by the arrow.

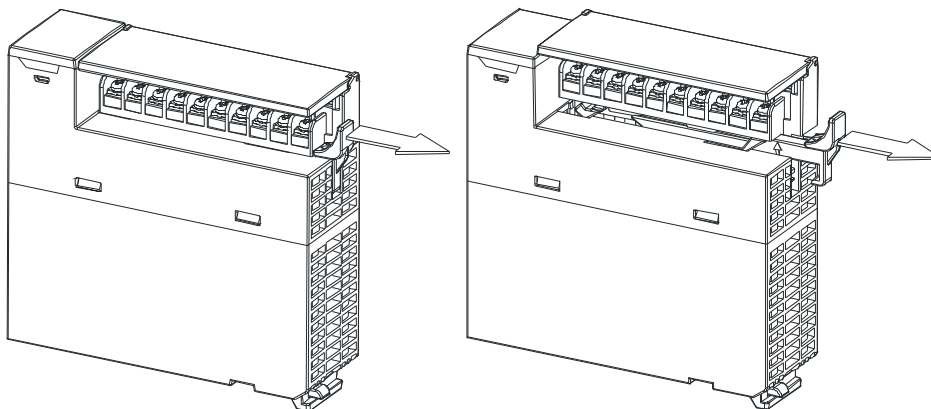

2. Pull up the clip.

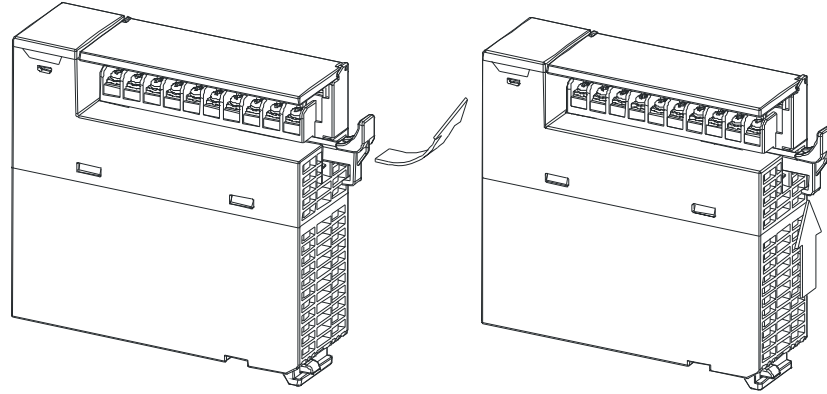

3. The terminal block is removed.

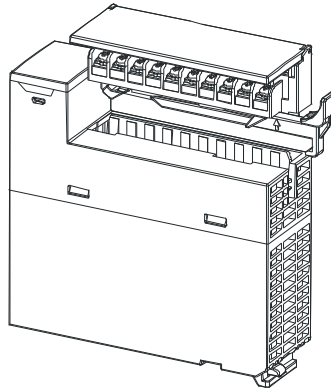

2.3.5 Installing a Wiring Module

- **Installation**

1. One side of a wiring module has to be fixed first.
2. Press the driver board in the direction indicated by arrow 1, and make sure that the groove is combined with the DIN rail.

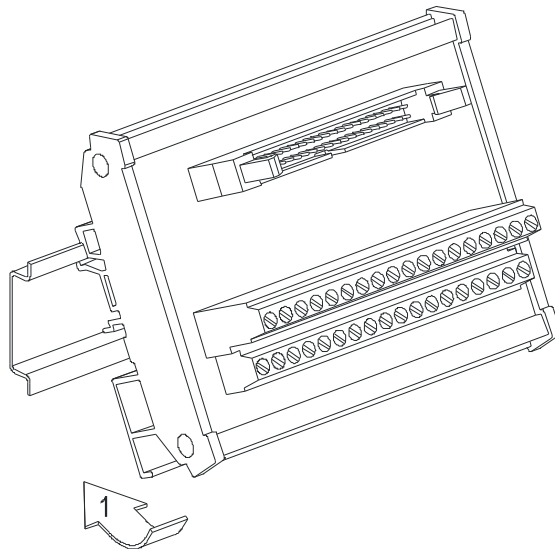

● **Removal**

1. Push the wiring module in the direction indicated by arrow 1.
2. Pull the wiring module in the direction indicated by arrow 2.

2

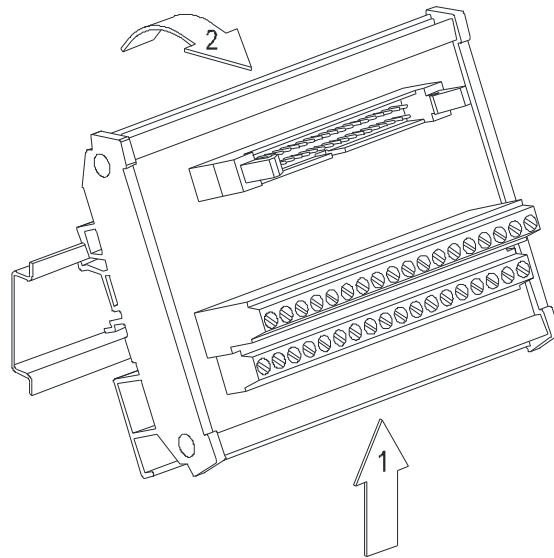

2.3.6 Connecting Backplanes

Connect the backplanes through the extension cables, and make sure that the connectors of the cables are joined to the ports properly, as illustrated below.

● **Extension cable**

1. AHACAB06-5 A (0.6 m)
2. AHACAB10-5 A (1.0 m)
3. AHACAB15-5 A (1.5 m)
4. AHACAB30-5 A (3.0 m)

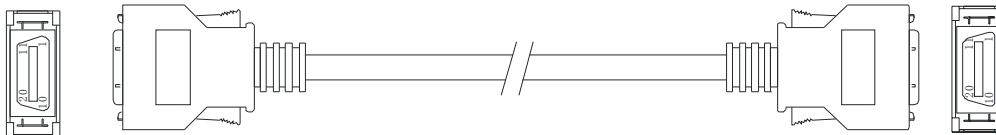

Note: The extension cable longer than 3 meters can be customized.

- Connecting the backplanes

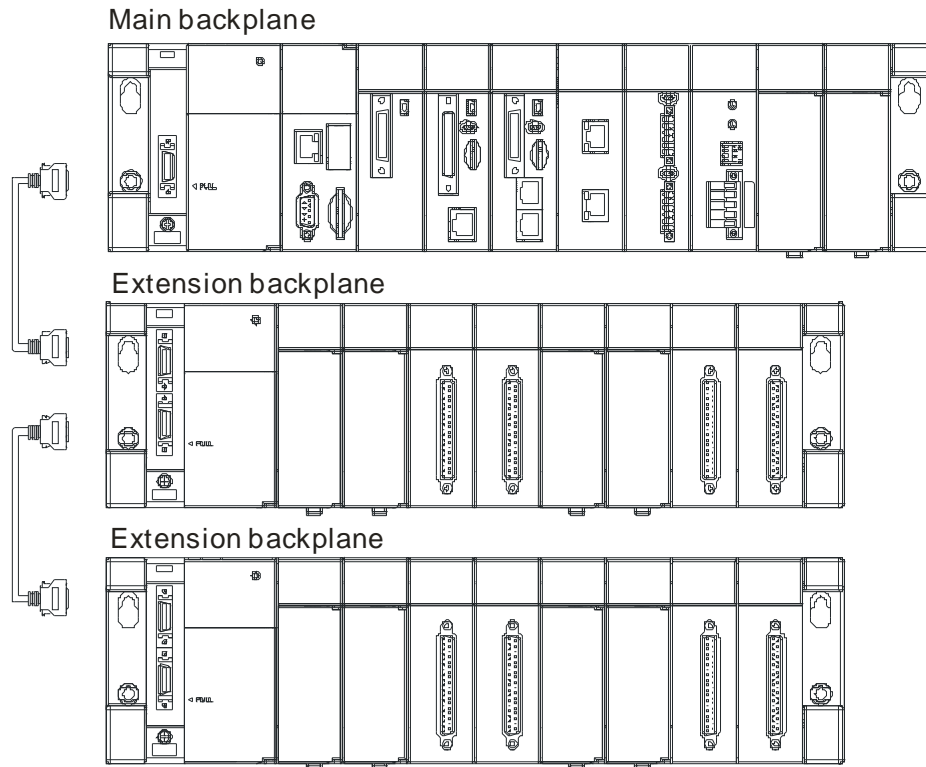

- Fiber optics modules for extension backplanes: AHAADP01EF-5A and AHAADP02EF-5A

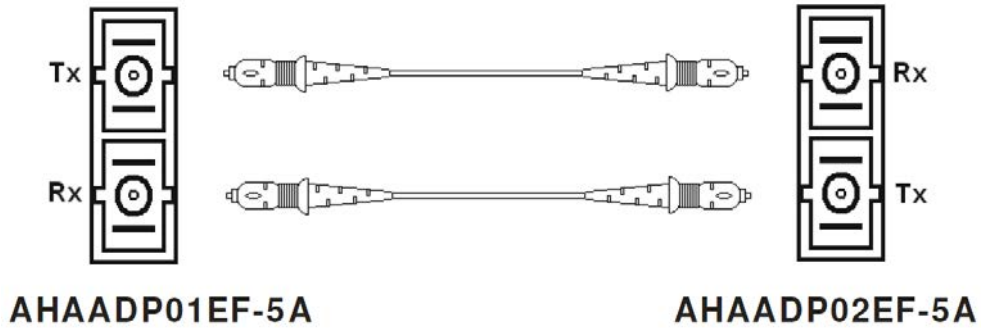

2.3.7 Connecting a Communication Cable

Put a communication cable in the port on a CPU module, and make sure that the connector of the cable is joined to the port properly.

2

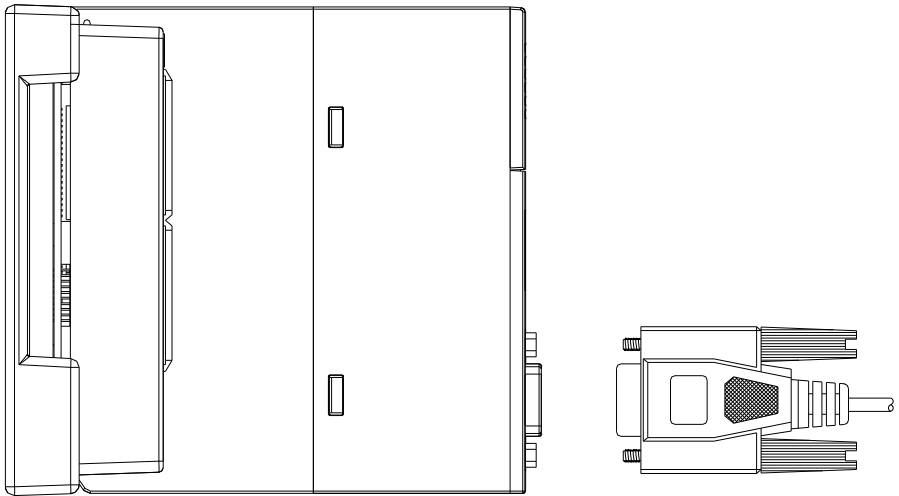

3

Chapter 3 Specifications for Products

Table of Contents

3.1	General Specifications.....	3-2
3.2	Specifications for CPU Modules	3-2
3.2.1	General Specifications.....	3-2
3.2.2	Profiles	3-4
3.2.3	Dimensions.....	3-5
3.3	Specifications for Backplanes.....	3-6
3.3.1	General Specifications.....	3-6
3.3.2	Profiles	3-7
3.3.3	Dimensions.....	3-9
3.4	Specifications for the Power Supply Module	3-11
3.4.1	General Specifications.....	3-11
3.4.2	Profile	3-12
3.4.3	Dimensions.....	3-13
3.4.4	Arrangement of Terminals	3-14
3.5	Specifications for Digital Input/Output Modules.....	3-15
3.5.1	General Specifications.....	3-15
3.5.2	Profiles	3-18
3.5.3	Dimensions.....	3-25
3.5.4	Arrangement of Input/Output Terminals.....	3-30
3.6	Specifications for Analog Input/Output Modules	3-40
3.6.1	General Specifications.....	3-40
3.6.2	Profiles	3-45
3.6.3	Dimensions.....	3-46
3.6.4	Arrangement of Input/Output Terminals.....	3-47
3.7	Specifications for Temperature Measurement Modules	3-48
3.7.1	General Specifications.....	3-48
3.7.2	Profiles	3-50
3.7.3	Dimensions.....	3-52
3.7.4	Arrangement of Input/Output Terminals.....	3-53
3.8	Specifications for Network Modules	3-54
3.8.1	General Specifications.....	3-54
3.8.2	Profiles	3-57
3.8.3	Dimensions.....	3-64
3.8.4	Arrangement of Input/Output Terminals.....	3-67
3.9	Specifications for Motion Control Modules	3-68
3.9.1	General Specifications.....	3-68
3.9.2	Profiles	3-80
3.9.3	Dimensions.....	3-87
3.9.4	Arrangement of Input/Output Terminals.....	3-91
3.10	Specifications for the Remote I/O Modules	3-96
3.10.1	General Specifications.....	3-96
3.10.2	Profiles.....	3-97
3.10.3	Dimensions.....	3-99
3.11	Space Module and Extension Cables.....	3-100
3.11.1	General Specifications.....	3-100
3.11.2	Profiles.....	3-101
3.11.3	Dimensions.....	3-102

3.1 General Specifications

Item	Specifications
Operating temperature	-20~60°C
Storage temperature	-40~70°C
Operating humidity	5~95% No condensation
Storage humidity	5~95% No condensation
Vibration/Shock resistance	International standards IEC 61131-2, IEC 68-2-6 (TEST Fc)/ IEC 61131-2 & IEC 68-2-27 (TEST Ea)
Work environment	No corrosive gas exists.
Installation location	In a control box
Pollution degree	2

3

3.2 Specifications for CPU Modules

3.2.1 General Specifications

Item	AHCPU500/510/520/530 -RS2	AHCPU500/510/520/530 -EN	Remark
Execution	The program is executed cyclically.		
Input/Output control	Regenerated inputs/outputs Direct inputs/outputs		The inputs and outputs can be controlled through the direct inputs and direct outputs.
Programming language	IEC 61131-3 Ladder diagrams, function block diagrams, instruction lists, structured texts, and sequential function charts		
Instruction execution speed	0.3 ms/K steps		
Number of instructions	Approximately 666 instructions		
Constant scan cycle (ms)	1-32000 (The scan cycle can be increased by one millisecond.)		Setting the parameter
Program capacity (step)	32K steps (AHCPU500) 64K steps (AHCPU510) 128K steps (AHCPU520) 256K steps (AHCPU530)		
Installation	DIN rails or screws		
Installation of a module	A module is installed directly on a backplane.		
Connection between two backplanes	An extension cable connects two backplanes.		
Maximum number of modules which can be installed	Twelve input/output modules at most can be installed on a main backplane. Eight input/output modules at most can be installed on an extension backplane. Seven extension backplanes at most can be connected. Sixty-eight input/output modules at most can be installed.		
Maximum number of backplanes which can be connected	AHCPU500: 1 backplane (1 main backplane) AHCPU510: 2 backplanes (1 main backplane+1 extension backplane) AHCPU520: 4 backplanes (1 main backplane+3 extension backplanes) AHCPU530: 8 backplanes (1 main backplane+7 extension backplanes)		

Item	AHCPU500/510/520/530 -RS2	AHCPU500/510/520/530 -EN	Remark
Number of tasks	283 tasks (32 cyclic tasks; 32 I/O interrupts; 4 timed interrupts; 2 communication interrupts; 1 external 24 V low-voltage interrupt; 212 external interrupts)		
Number of input/output devices	8192 (X0.0~X511.15/Y0.0~Y511.15)		Number of devices which can be used in a program
Number of inputs/outputs	AHCPU500: 768 AHCPU510: 1280 AHCPU520: 2304 AHCPU530: 4352		Number of inputs/outputs accessible to an actual input/output module
Input relays [X]	AHCPU500: 1024 (X0.0~X63.15) AHCPU510: 2048 (X0.0~X127.15) AHCPU520: 4096 (X0.0~X255.15) AHCPU530: 8192 (X0.0~X511.15)		
Output relays [Y]	AHCPU500: 1024 (Y0.0~Y63.15) AHCPU510: 2048 (Y0.0~Y127.15) AHCPU520: 4096 (Y0.0~Y255.15) AHCPU530: 8192 (Y0.0~Y511.15)		
Internal relays [M]	8192 (M0~M8191)		
Link registers [L]	AHCPU500: 16384 (L0~L16383) AHCPU510: 32768 (L0~L32767) AHCPU520: 65536 (L0~L65535) AHCPU530: 65536 (L0~L65535)		
Timers [T]	2048 (T0~T2047)		
Counters [C]	2048 (C0~C2047)		
32-bit counter [HC]	64 (HC0~HC63)		
Data register [D]	AHCPU500:16384 (D0~D16383) AHCPU510: 32768 (D0~D32767) AHCPU520: 65536 (D0~D65535) AHCPU530: 65536 (D0~D65535)		
Stepping relay [S]	2048 (S0~S2047)		
Index register [E]	32 (E0~E31)		
Special auxiliary relay [SM]	2048 (SM0~SM2047)		
Special data register [SR]	2048 (SR0~SR2047)		
Serial communication port	Two RS-232/RS-485/RS-422 communication ports	One RS-232/RS-485/RS-422 communication port	
Ethernet port	-	10/100 M	
USB port	Mini USB		
Storage interface	SD Card (SD 1.0)		
Remote RUN/STOP	The setting range is X0.0~X511.15.		
Real-time clock	Years, months, days, hours, minutes, seconds, and weeks		

3.2.2 Profiles

● AHCPU500-RS2/AHCPU510-RS2/AHCPU520-RS2/AHCPU530-RS2

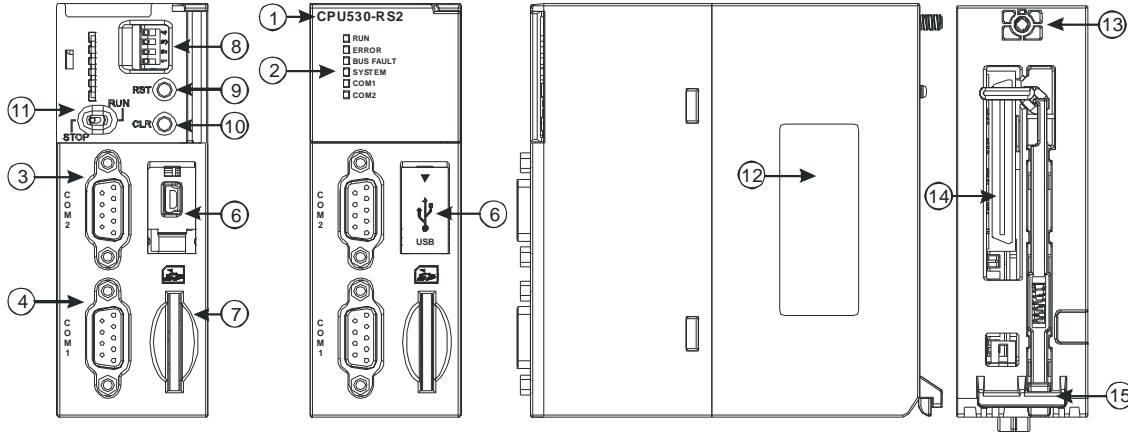

● AHCPU500-EN/AHCPU510-EN/AHCPU520-EN/AHCPU530-EN

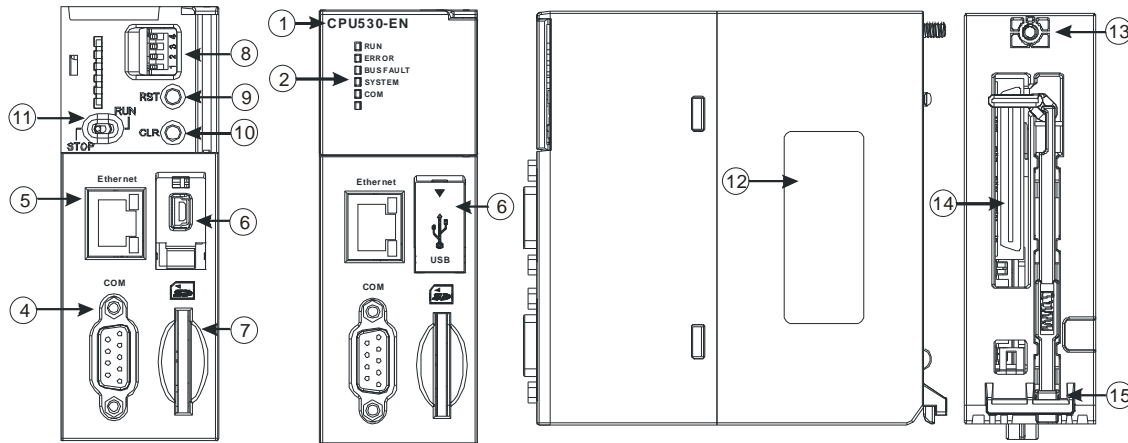

Number	Name	Description
1	Model name	Model name of the CPU module
2	RUN LED indicator	Operating status of the CPU module ON: The user program is being executed. OFF: The execution of the user program stops. Blinking: The user program is in a debugging mode.
	ERROR LED indicator	Error status of the CPU module ON: A serious error occurs in the system. OFF: The system is normal. Blinking: A slight error occurs in the system.
	BUS FAULT LED indicator	Error status of the I/O bus ON: A serious error occurs in the I/O bus. OFF: The I/O bus is normal. Blinking: A slight error occurs in the I/O bus.
2	SYSTEM LED indicator	System status of the CPU module ON: The external input/output is forced ON/OFF. OFF: The system is in a default status. Blinking: The CPU module is being reset./The value in the device is being cleared.
	COM LED indicator COM1 LED indicator COM2 LED indicator	Communication status of the communication port OFF: There is no communication through the communication port. Blinking: There is communication through the communication port.
3	COM2	Providing the RS-232/RS-485/RS-422 communication interface
4	COM1/COM	Providing the RS-232/RS-485/RS-422 communication interface

Number	Name	Description
5	Ethernet port	Providing the Ethernet communication interface
6	USB port	Providing the mini USB communication interface
7	SD slot	Providing the SD interface
8	DIP switch	Function which the system executes
		SW1 OFF: No action (default) ON: Write protection
		SW2 OFF: No action (default) ON: The system is copied when the CPU module is supplied with powered. (The user program, the CPU paramter, the module table, and the setting values in the devices are copied from the memory card to the CPU module.)
		SW3 OFF: No action (default) ON: It is used with the CLR button to backup the system. (The user program, the CPU paramter, the module table, and the setting values in the devices are backed up from the memory card to the CPU module.)
SW4 It is used with SW3. OFF: When the system is backupper, the values in the devices are backupper. ON: When the system is backupper, the values in the devices are not backupper.		
9	RST button	Resetting the CPU module, and restoring it to the default factory value
10	CLR button	Clearing the value in the latched device
11	RUN/STOP switch	RUN: The user program is executed. STOP: The execution of the user program stops.
12	Label	Nameplate
13	Set screw	Fixing the module
14	Connector	Connecting the module and a backplane.
15	Projection	Fixing the module

3

3.2.3 Dimensions

- AHCPU500-RS2/AHCPU510-RS2/AHCPU520-RS2/AHCPU530-RS2

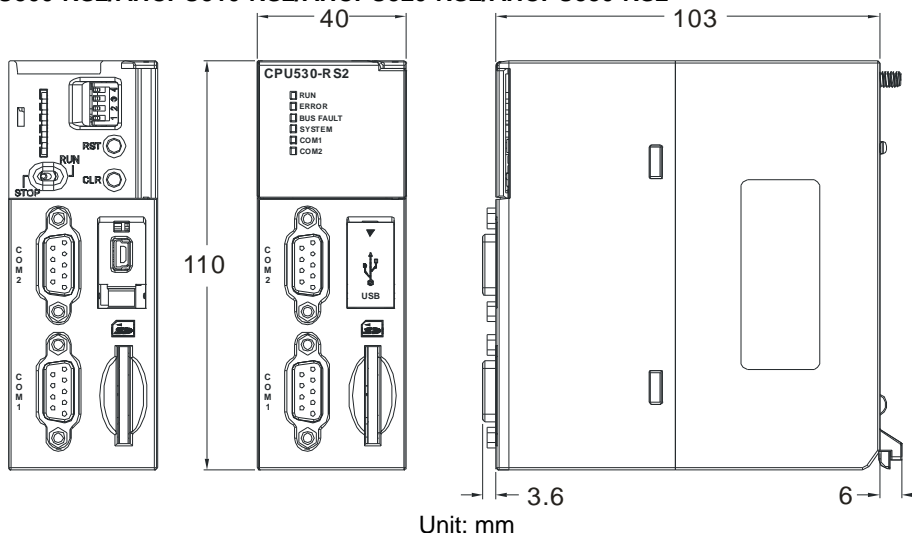

Unit: mm

- AHCPU500-EN/AHCPU510-EN/AHCPU520-EN/AHCPU530-EN

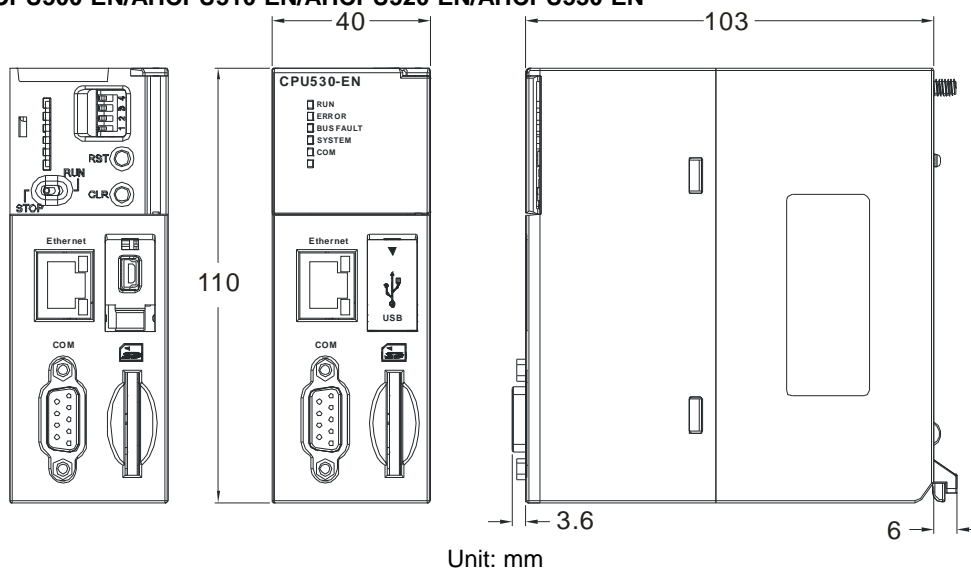

3.3 Specifications for Backplanes

3.3.1 General Specifications

- Specifications for main backplanes

Model	AHBP04M1-5A	AHBP06M1-5A	AHBP08M1-5A	AHBP12M1-5A
Item				
Number of slots	4	6	8	12
Applicable power supply module	AHPS05-5A			
Applicable input/output module	The AH500 series input/output modules can be installed.			

- Specifications for extension backplanes

Model	AHBP06E1-5A	AHBP08E1-5A
Item		
Number of slots	6	8
Applicable power supply module	AHPS05-5A	
Applicable input/output module	Digital input/output modules, analog input/output modules, temperature measurement module, and AH10SCM-5A	

3.3.2 Profiles

- Profile of the main backplane AHBP08M1-5A

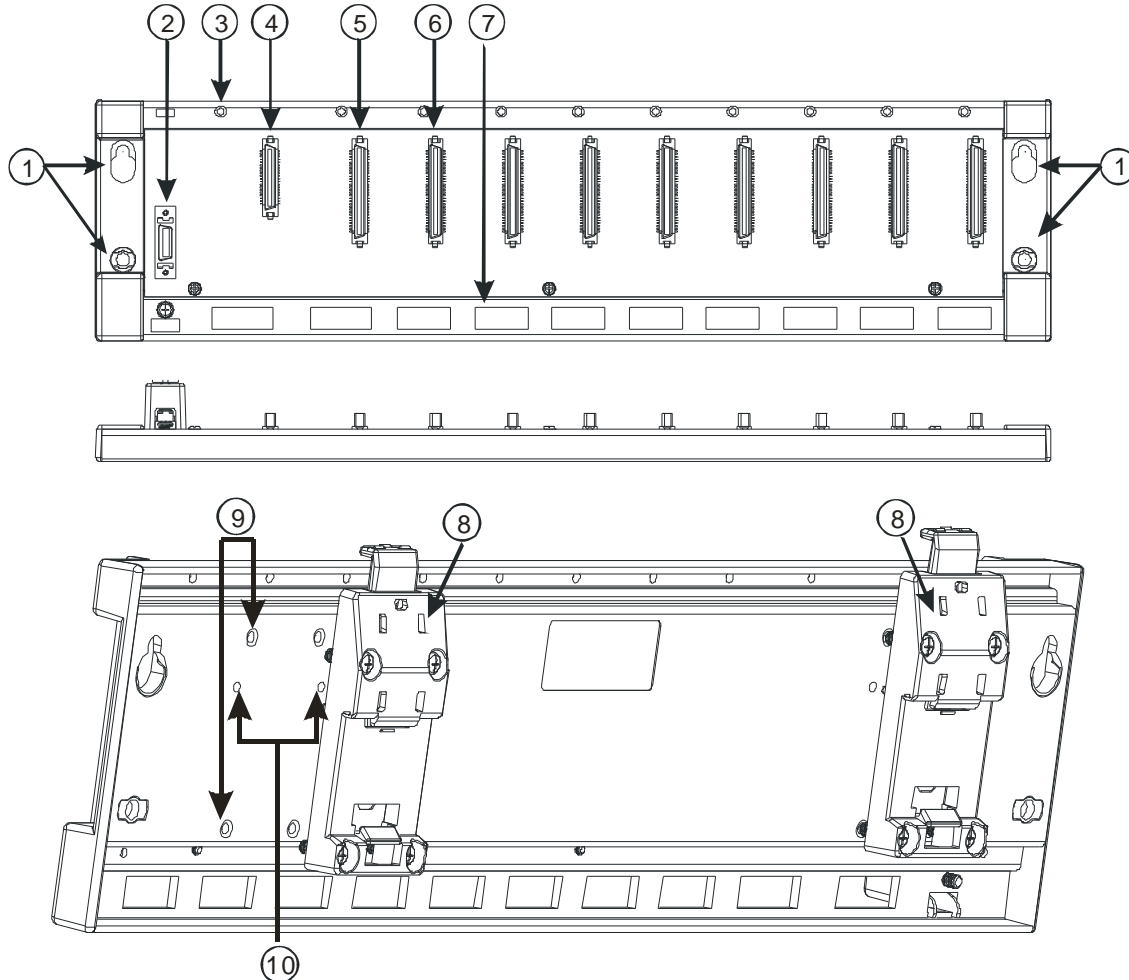

3

Number	Name	Description
1	Mounting hole	Fixing the backplane
2	Extension port	It is connected to an inferior backplane.
3	Mounting hole	After a module is installed, it is fixed by a screw.
4	Connector	Connecting the backplane and a power supply module
5	Connector	Connecting the backplane and a CPU module
6	Connector	Connecting the backplane and an input/output module
7	Hole	The projection under a module is inserted into this hole.
8	Mounting clip	Hanging a backplane on a DIN rail
9	Mounting hole	After a mounting clip is installed, it is fixed by screws.
10	Locating hole	A mounting clip is pressed into these locating holes.

● Profile of the extension backplane AHBP08E1-5A

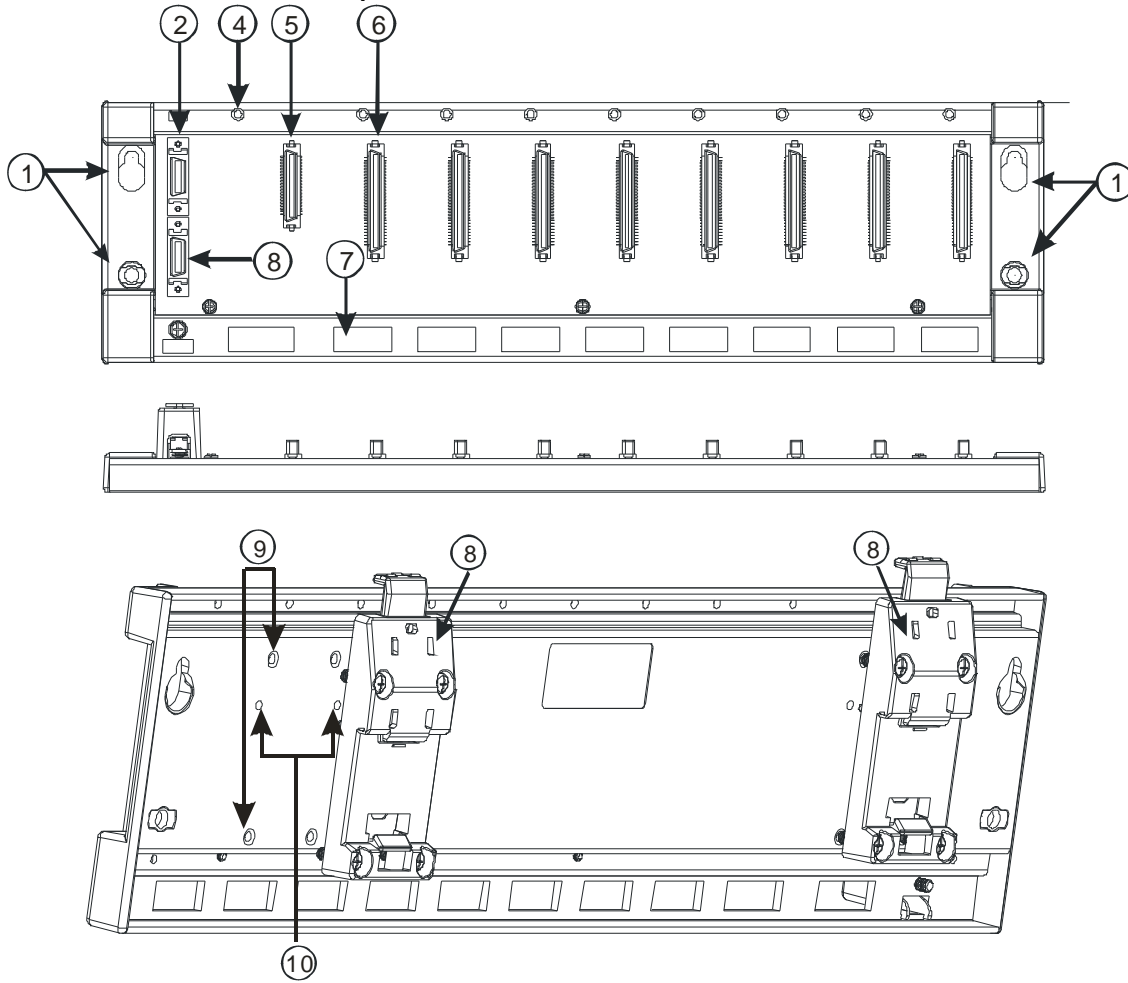

3

Number	Name	Description
1	Mounting hole	Fixing the backplane
2	Extension port 1	It is connected to a superior backplane.
3	Extension port 2	It is connected to an inferior backplane.
4	Connector	Connecting the backplane and a power supply module
5	Connector	Connecting the backplane and an input/output module
6	Mounting hole	After a module is installed, it is fixed by a screw.
7	Hole	The projection under a module is inserted into this hole.
8	Mounting clip	Hanging a backplane on a DIN rail
9	Mounting hole	After a mounting clip is installed, it is fixed by screws.
10	Locating hole	A mounting clip is pressed into these locating holes.

3.3.3 Dimensions

- Main backplane AHBP04M1-5A

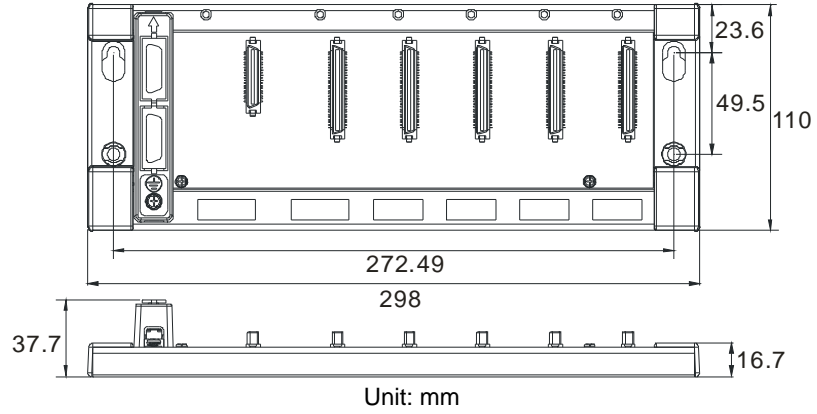

- Main backplane AHBP06M1-5A

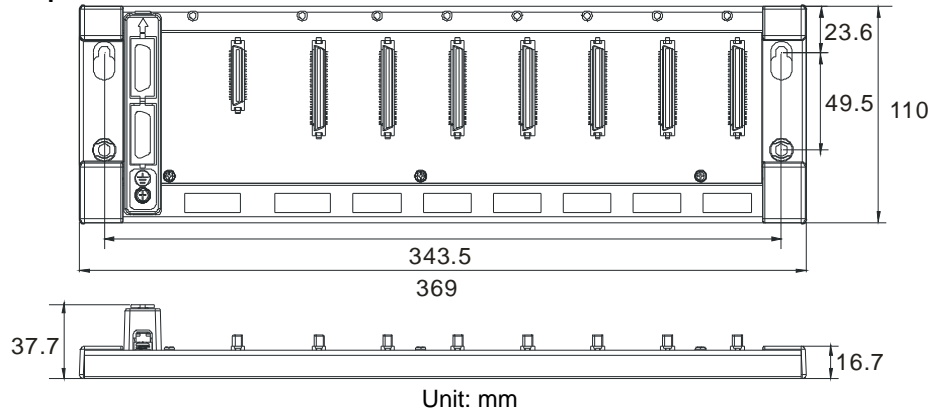

- Main backplane AHBP08M1-5A

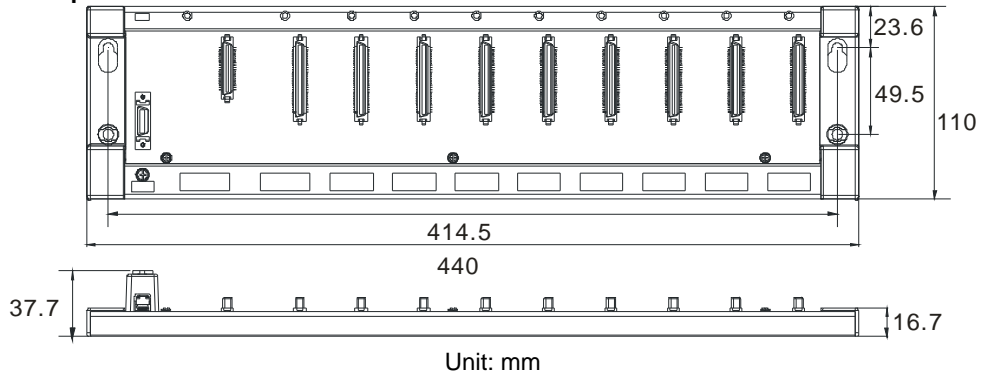

● Main backplane AHBP12M1-5A

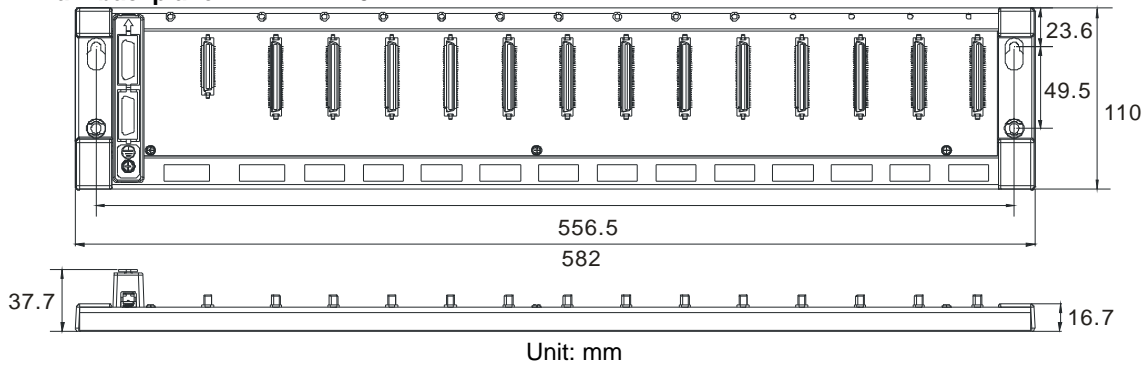

3

● Extension backplane AHBP06E1-5A

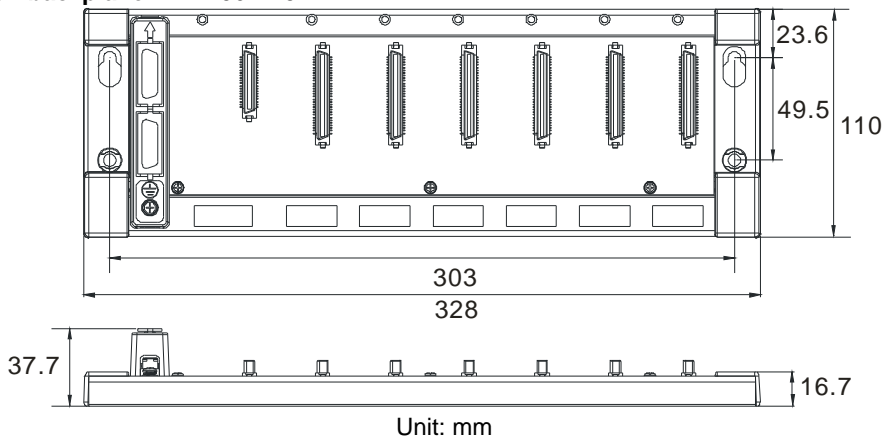

● Extension backplane AHBP08E1-5A

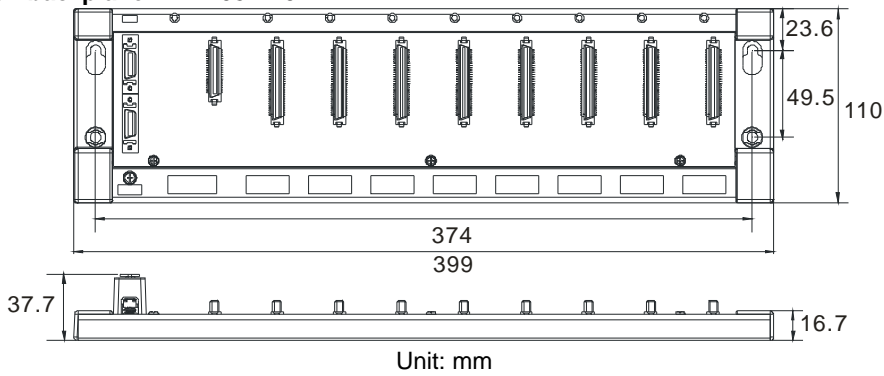

3.4 Specifications for the Power Supply Module

3.4.1 General Specifications

- AHPS05-5A

Item	Specifications
Supply voltage	100~240 V AC (-15%~10%) 50/60 Hz±5%
Action specifications	If the input power supply is larger than 85 V AC, the power supply module can function normally.
Allowable instantaneous power failure time	If the instantaneous power failure time is within ten milliseconds, the power supply module keeps running.
Fuse	4 A/250 V AC
Inrush current	45 A within 1 millisecond at 115 V AC
24 V DC output	The maximum current is 2.5 A. It is only for a backplane.
Power protection	The 24 V DC output is equipped with the short circuit protection and the overcurrent protection.
Surge voltage withstand level	1,500 V AC (Primary-secondary), 1,500 V AC (Primary-PE), 500 V AC (Secondary-PE)
Insulation voltage	Above 5 MΩ (The voltage between all inputs/outputs and the ground is 500 V DC.)
Ground	The diameter of the ground should not be less than the diameters of the cables connected to the terminals L and N.

- AHPS15-5A

Item	Specifications
Supply voltage	24 V DC (-35%, +30%)
Allowable instantaneous power failure time	10 milliseconds
Fuse	6.3 A/250 V AC
Inrush current	30 A within 100 milliseconds
24 V DC output	1.5 A
Maximum output power	36 W
Power protection	The 24 V DC output is equipped with the short circuit protection, the overcurrent protection, and the overvoltage protection.
Surge voltage withstand level	500 V AC
Ground	The diameter of the ground should be greater than 1.6 mm ² .

3.4.2 Profile

● AHPS05-5A

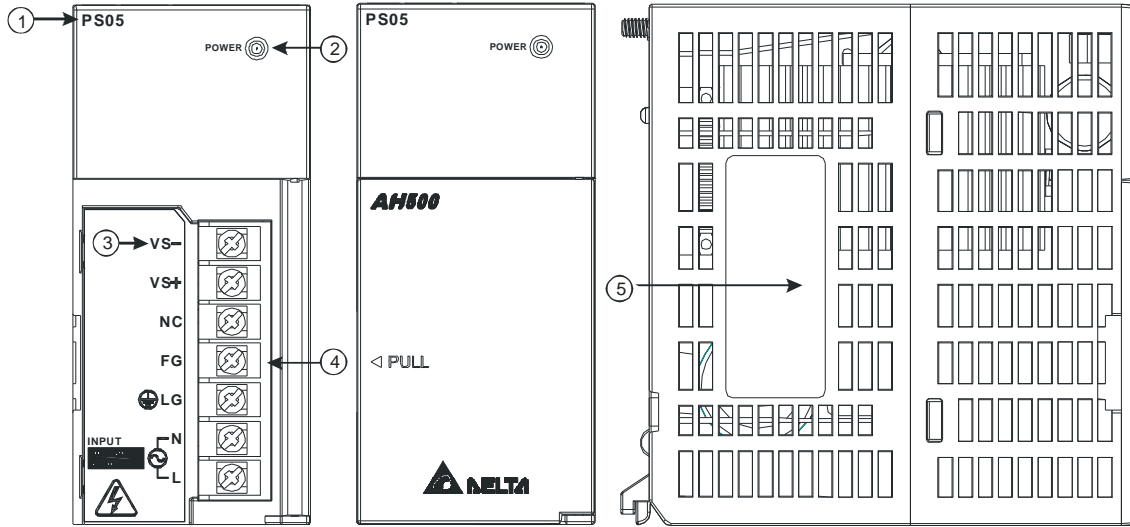

Number	Name	Description
1	Model name	Model name of the power supply module
2	POWER LED indicator (green)	Indicating the status of the power supply
3	Arrangement of the terminals	VS-: It is connected to the negative 24 V DC power supply. VS+: It is connected to the positive 24 V DC power supply. NC: No connection FG: Functional ground LG: Line ground L/N: AC power input
4	Terminal	Terminal for wiring
5	Label	Nameplate

● AHPS15-5A

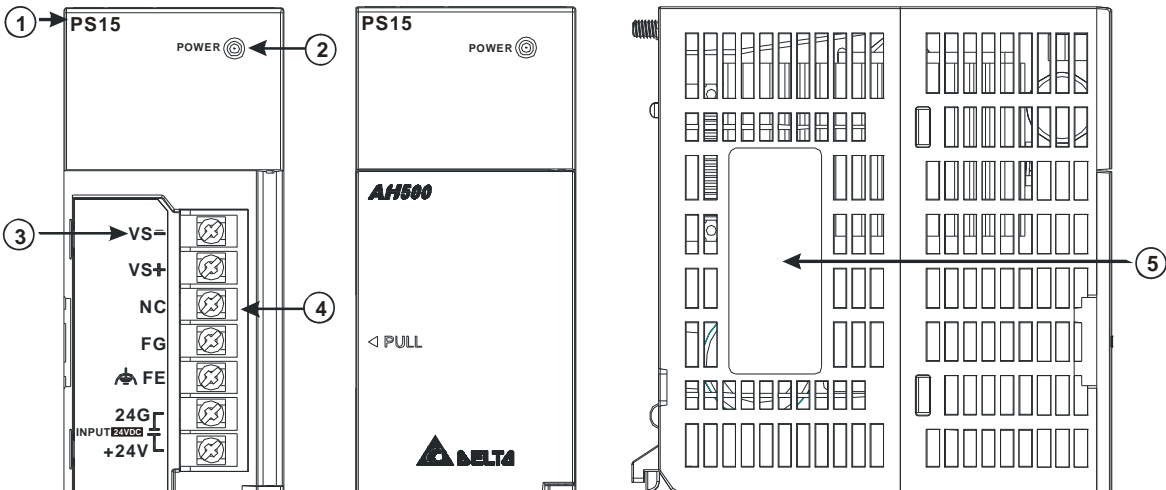

Number	Name	Description
1	Model name	Model name of the power supply module
2	POWER LED indicator (green)	Indicating the status of the power supply

Number	Name	Description
3	Arrangement of the terminals	VS-: It is connected to the negative 24 V DC power supply. VS+: It is connected to the positive 24 V DC power supply. NC: No connection FG: Functional ground FE: Line ground 24G/+24V: DC power input
4	Terminal	Terminal for wiring
5	Label	Nameplate

3.4.3 Dimensions

- AHPS05-5A

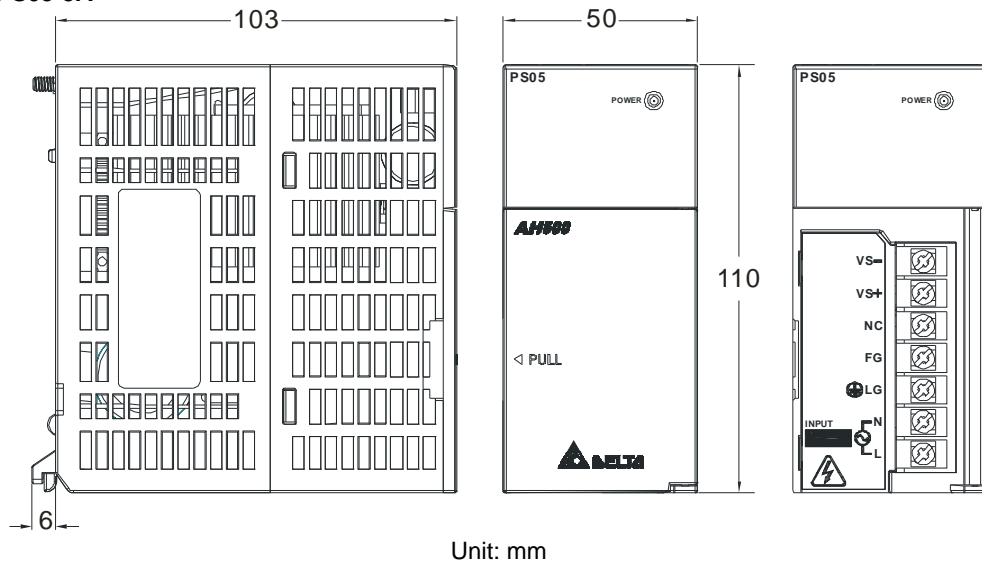

- AHPS15-5A

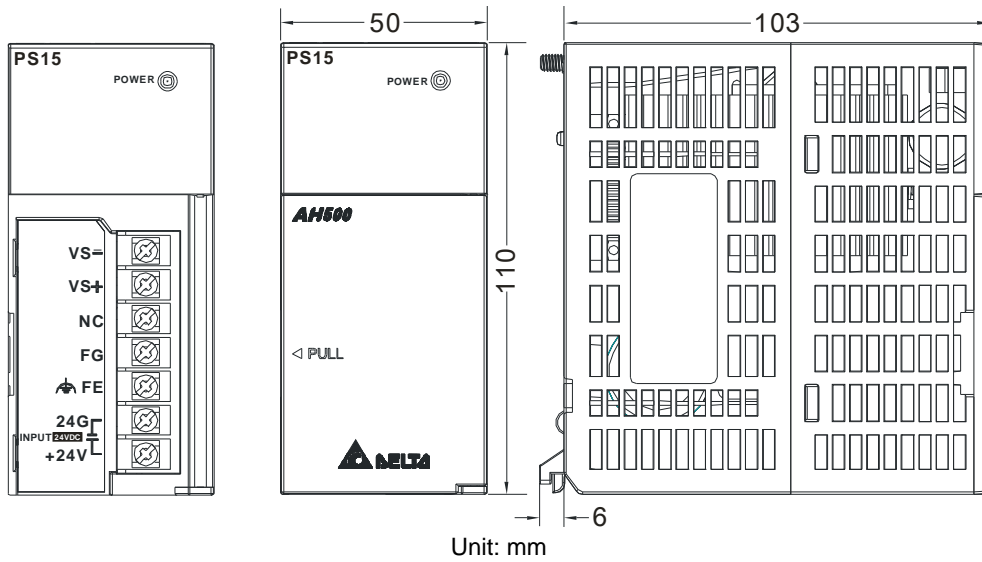

3

3.4.4 Arrangement of Terminals

● AHPS05-5A

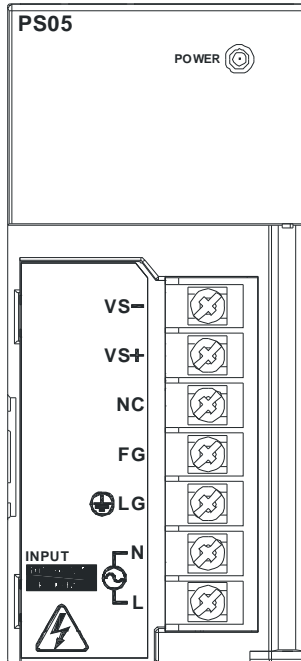

- VS-: It is connected to the negative 24 V DC power supply, and used to detect the external power supply.
- VS+: It is connected to the positive 24 V DC power supply, and used to detect the external power supply.
- NC: No connection
- FG: Functional ground
- LG: Line ground
- L/N: AC power input

● AHPS15-5A

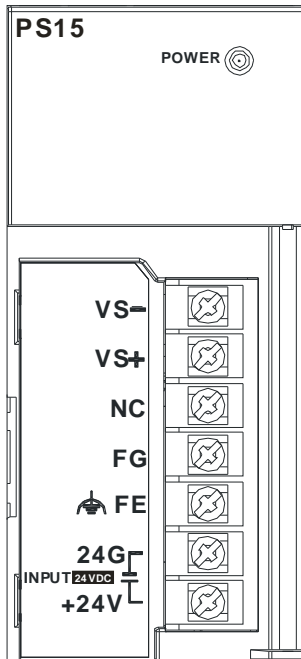

- VS-: It is connected to the negative 24 V DC power supply, and used to detect the external power supply.
- VS+: It is connected to the positive 24 V DC power supply, and used to detect the external power supply.
- NC: No connection
- FG: Functional ground
- FE: Line ground
- 24G/+24V: DC power input

3.5 Specifications for Digital Input/Output Modules

3.5.1 General Specifications

- Electrical specifications for the inputs on digital input/output modules (The signals passing through the inputs are 24 V DC signals.)

Model		AH16AM10N	AH32AM10N	AH32AM10N	AH32AM10N	AH64AM10N	AH16AP11R	AH16AP11T	AH16AP11P
Item		-5A	-5A	-5B	-5C	-5C	-5A	-5A	-5A
Number of inputs		16	32	32	32	64	8	8	8
Connector type		Removable terminal block		DB37 connector	Latch connector		Removable terminal block		
Input type		Digital input							
Input form		Direct current (sinking or sourcing)							
Input current		24 V DC 5 mA			24 V DC 3.2 mA		24 V DC 5 mA		
Action level	OFF→ON	>15 V DC							
	ON→OFF	<5 V DC							
Response time	OFF→ON	10 ms±10%							
	ON→OFF	15 ms±10%							
Maximum input frequency		50 Hz							
Input impedance		4.7 kΩ			7.5 kΩ		4.7 kΩ		
Input signal		Voltage input Sinking: The inputs are NPN transistors whose collectors are open collectors. Sourcing: The inputs are PNP transistors whose collectors are open collectors.							
Electrical isolation		Optocoupler							
Input display		When the optocoupler is driven, the input LED indicator is ON.							

- Electrical specifications for the inputs on a digital input/output module (The signals passing through the inputs are alternating current signals ranging in voltage from 120 V to 240 V.)

Model		AH16AM30N-5A
Item		
Number of inputs		16
Connector type		Removable terminal block
Input type		Digital input
Input form		Alternating current
Input current		120 V AC and 4.5 mA; 240 V AC and 9 mA
Action level	OFF→ON	>79 V AC
	ON→OFF	<40 V AC
Response time	OFF→ON	15 ms
	ON→OFF	30 ms
Electrical isolation		Optocoupler
Input display		When the optocoupler is driven, the input LED indicator is ON.

- Electrical specifications for the inputs on a digital input/output module which supports I/O interrupts (The signals passing through the inputs are 24 V DC signals.)

Model		16AR10N-5A
Item		
Number of inputs		16
Input power form		Direct current
Connector type		Removable terminal block
Input type		Digital input
Input form		Direct current (sinking or sourcing)
Input current		24 V DC, 5 mA

3

3

Model		16AR10N-5A				
Action level	OFF→ON	>15 V DC				
	ON→OFF	<5 V DC				
Response time	Filtering cycle	0.1 ms	0.5 ms	3 ms	15 ms	20 ms
	OFF→ON (Typical)	0.11 ms	0.51 ms	3.01 ms	15.01 ms	20.01 ms
	OFF→ON (Maximum)	0.12 ms	0.52 ms	3.02 ms	15.02 ms	20.02 ms
	ON→OFF (Typical)	0.11 ms	0.51 ms	3.01 ms	15.01 ms	20.01 ms
	ON→OFF (Maximum)	0.15 ms	0.55 ms	3.05 ms	15.05 ms	20.05 ms
Input impedance	ON→OFF					
Input signal	Voltage input Sinking: The inputs are NPN transistors whose collectors are open collectors. Sourcing: The inputs are PNP transistors whose collectors are open collectors.					
Electrical isolation	Optocoupler					
Input display	When the optocoupler is driven, the input LED indicator is ON.					
Trigger for an interrupt	An interrupt is triggered when there is a transition in a signal from low to high/from high to low/from low to high or from high to low.					
Interrupt service routine	The interrupt service routine numbers which can be set are in the range of 0 to 31.					
Filtering cycle which can be set for an input channel	0.1 ms, 0.5 ms, 3 ms (default), 15 ms, or 20 ms					

● Electrical specifications for the outputs on digital input/output modules

Model		AH16AN01R	AH16AP11R	AH16AN01T	AH16AP11T	AH16AN01P	AH16AP11P	AH16AN01S
		-5A	-5A	-5A	-5A	-5A	-5A	-5A
Number of outputs		16	8	16	8	16	8	16
Connector type		Removable terminal block						
Output type		Realy-R		Transistor-T (sinking)		Transistor-P (sourcing)		TRIAC-S
Voltage specifications		250 V AC, and below 30 V DC		12~30 V DC ^{*2}		12~30 V DC ^{*2}		120/240 V AC
Maximum load	Resistance	2 A/output (5 A/COM)		0.5 A/output (4 A/COM)		0.5 A/output (4 A/COM)		0.5 A/output (2 A/COM)
	Inductance	Life cycle curve ^{*3}		12 W (24 V DC)		12 W (24 V DC)		Not applicable
	Bulb	20 W (24 V DC) 100 W (230 V AC)		2 W (24 V DC)		2 W (24 V DC)		60 W AC
Maximum output frequency ^{*1}	Resistance	1 Hz		100 Hz		100 Hz		10 Hz
	Inductance	0.5 Hz		0.5 Hz		0.5 Hz		-
	Bulb	1 Hz		10 Hz		10 Hz		10 Hz
Maximum Response time	OFF→ON	10 ms		0.5 ms		0.5 ms		1 ms+0.5 AC cycles
	ON→OFF							

Model	AH32AN02T	AH32AN02P	AH32AN02	AH32AN02	AH32AN02	32AN02P-	AH64AN02T	AH64AN02P
Item	-5A	-5A	T-5B	P-5B	T-5C	5C	-5C	-5C
Number of outputs	32	32	32	32	32	32	64	64
Connector type	Removable terminal block		DB37 connector		Latch connector			
Output type	Transistor-T (sinking) Transistor-P (sourcing)							
Voltage specifications	12~30 V DC ^{*2}							
Maximum load	Resistance	0.1 A/output (1 A/COM)						
	Inductance	Not applicable						
	Bulb	Not applicable						
Maximum output frequency ^{*1}	Resistance	100 Hz						
	Inductance	-						
	Bulb	-						
Maximum Response time	OFF→ON	0.5 ms						
	ON→OFF							

*1: The scan cycle affects the frequency.

*2: The terminals UP and ZP needs to be connected to the 24 V DC auxiliary power supply (-15%~+20%), and the rated current consumption is 1 mA/output.

*3: The life cycle curve is shown below.

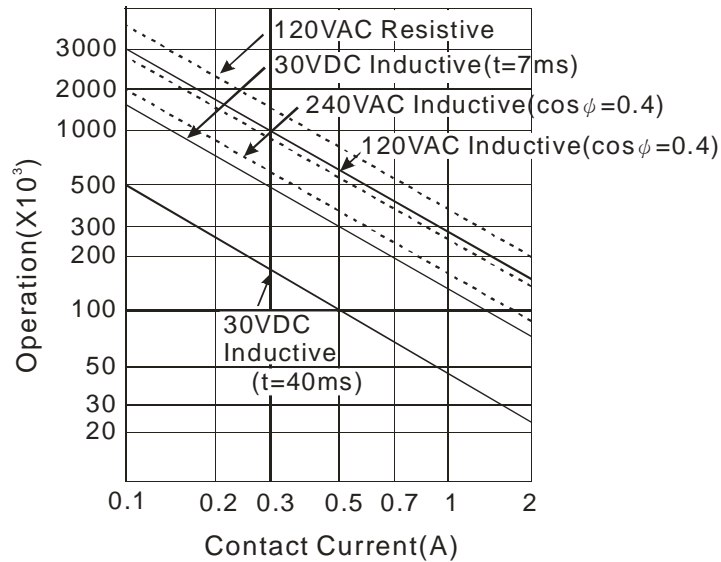

3.5.2 Profiles

- AH16AM10N-5A/AH16AM30N-5A/AH16AR10N-5A/AH16AN01S-5A/AH16AN01R-5A/AH16AN01T-5A/AH16AN01P-5A/AH16AP11R-5A/AH16AP11T-5A/AH16AP11P-5A

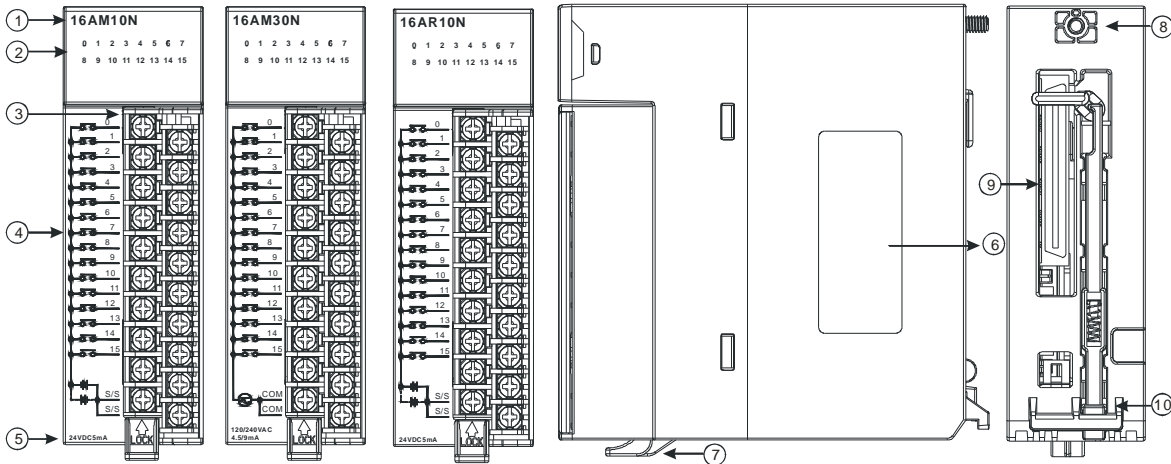

3

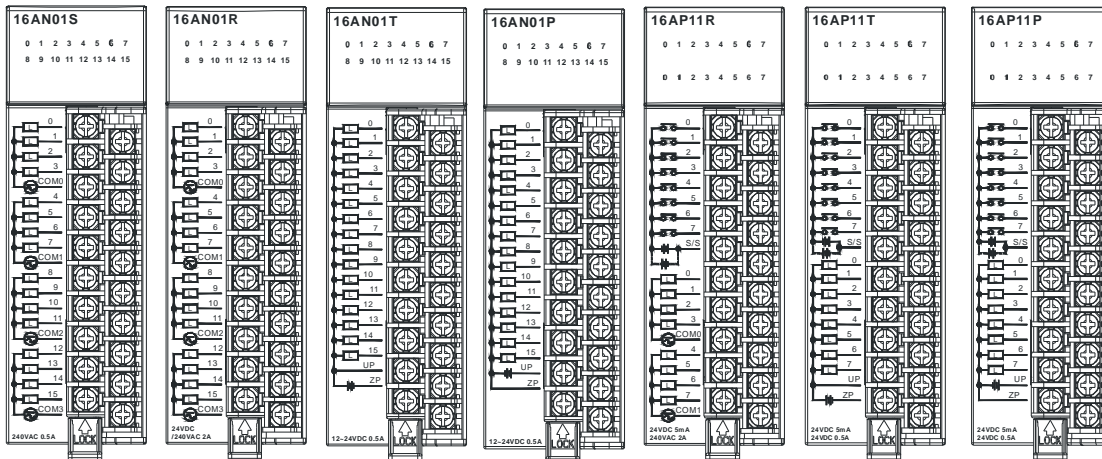

Number	Name	Description
1	Model name	Model name of the module
2	Input/Output LED indicator	If there is an input signal, the input LED indicator is ON. If there is an output signal, the output LED indicator is ON.
3	Removable terminal block	The inputs are connected to a switch or a sensor. The outputs are connected to a load which will be driven, e.g. a contact, or a solenoid valve.
4	Arrangement of the input/output terminals	Arrangement of the terminals
5	Description of the inputs/outputs	Number of inputs/outputs and specifications
6	Label	Nameplate
7	Clip	Fixing the removable terminal block
8	Set screw	Fixing the module
9	Connector	Connecting the module and a backplane
10	Projection	Fixing the module

● AH32AM10N-5A/AH32AN02T-5A/AH32AN02P-5A

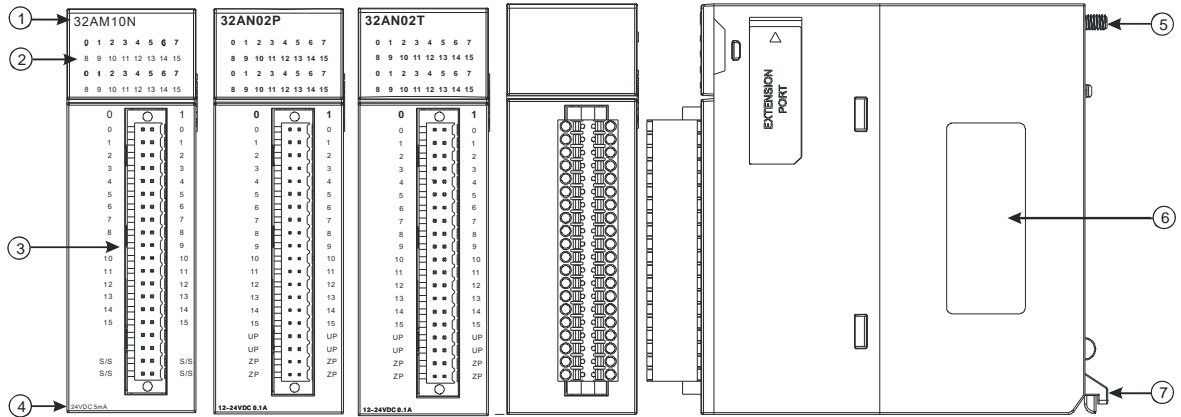

Number	Name	Description
1	Model name	Model name of the module
2	Input/Output LED indicator	If there is an input signal, the input LED indicator is ON. If there is an output signal, the output LED indicator is ON.
3	Removable terminal block	The inputs are connected to a switch or a sensor. The outputs are connected to a load which will be driven, e.g. a contact, or a solenoid valve.
4	Description of the inputs/outputs	Number of inputs/outputs and specifications
5	Set screw	Fixing the module
6	Label	Nameplate
7	Projection	Fixing the module

● AH32AM10N-5B/AH32AN02T-5B/AH32AN02P-5B

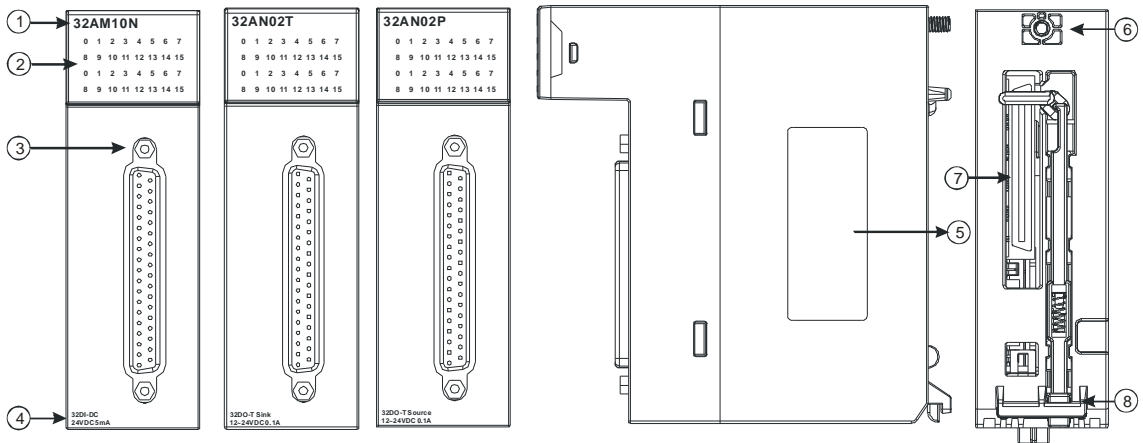

Number	Name	Description
1	Model name	Model name of the module
2	Input/Output LED indicator	If there is an input signal, the input LED indicator is ON. If there is an output signal, the output LED indicator is ON.
3	DB37 connector	It is connected to the I/O extension cable DVPACAB7C10.
4	Description of the inputs/outputs	Number of inputs/outputs and specifications
5	Label	Nameplate
6	Set screw	Fixing the module
7	Connector	Connecting the module and a backplane
8	Projection	Fixing the module

3

● AH32AM10N-5C/AH32AN02T-5C/AH32AN02P-5C

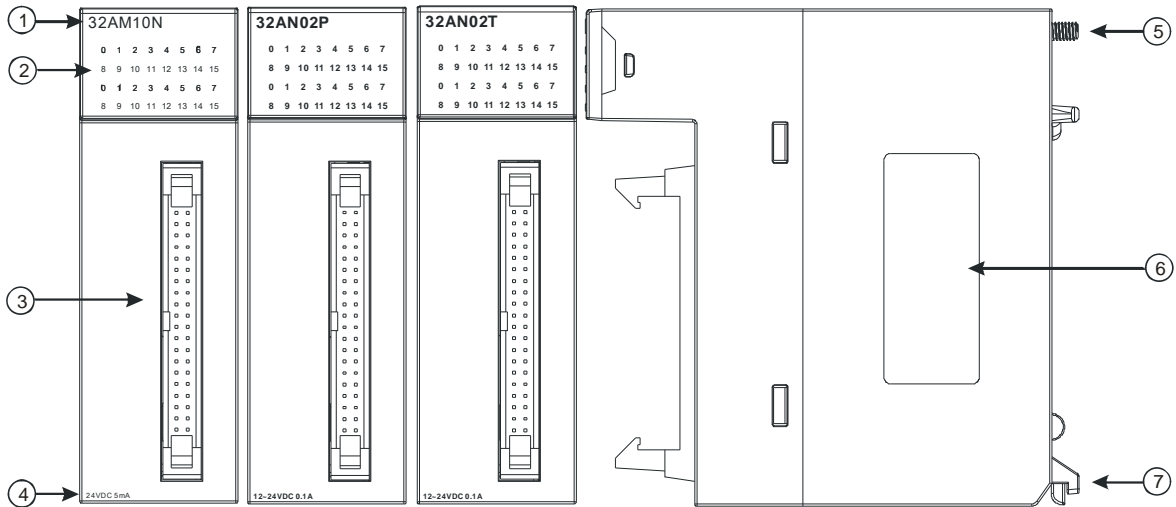

Number	Name	Description
1	Model name	Model name of the module
2	Input/Output LED indicator	If there is an input signal, the input LED indicator is ON. If there is an output signal, the output LED indicator is ON.
3	Latch connector	It is connected to the I/O extension cable DVPACAB7A10/DVPACAB7B10.
4	Description of the inputs/outputs	Number of inputs/outputs and specifications
5	Set screw	Fixing the module
6	Label	Nameplate
7	Projection	Fixing the module

● AH64AM10N-5C/AH64AN02T-5C/AH64AN02P-5C

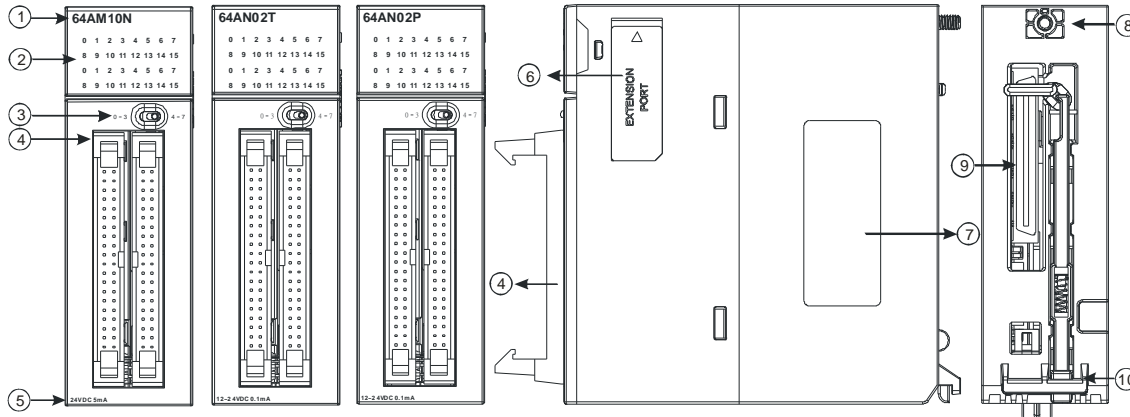

Number	Name	Description
1	Model name	Model name of the module
2	Input/Output LED indicator	If there is an input signal, the input LED indicator is ON. If there is an output signal, the output LED indicator is ON.
3	LED indicator switch	Left: High 32 bits Right: Low 32 bits
4	Latch connector	It is connected to the I/O extension cable DVPACAB7A10/DVPACAB7B10.
5	Description of the inputs/outputs	Number of inputs/outputs and specifications
6	Extension port	Updating the firmware

Number	Name	Description
7	Label	Nameplate
8	Set screw	Fixing the module
9	Connector	It connects the module and a backplane.
10	Projection	Fixing the module

● **DB37 connector, I/O extension cable, and external terminal module**

1. I/O extension cable DVPACAB7C10

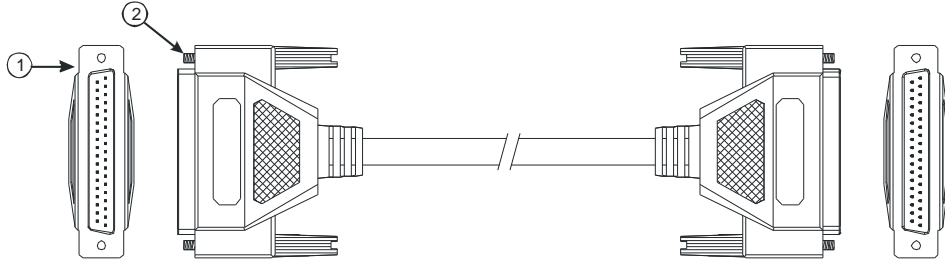

Number	Name	Description
1	DB37 connector	Connecting a digital input/output module and an external terminal module.
2	Set screw	Fixing the connector

2. External terminal module for AH32AM10N-5B: DVPAETB-ID32B

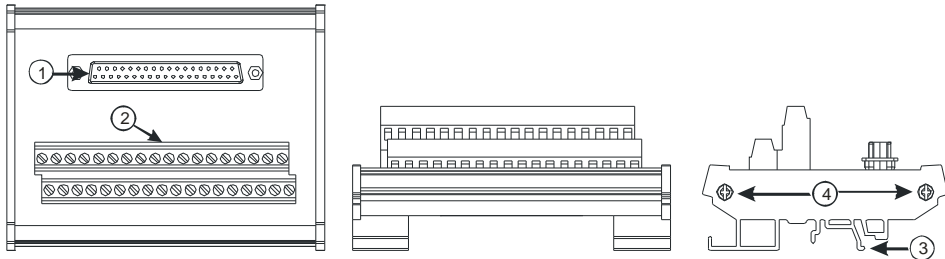

3. External terminal modules for AH32AN02T-5B

◆ DVPAETB-OR32A

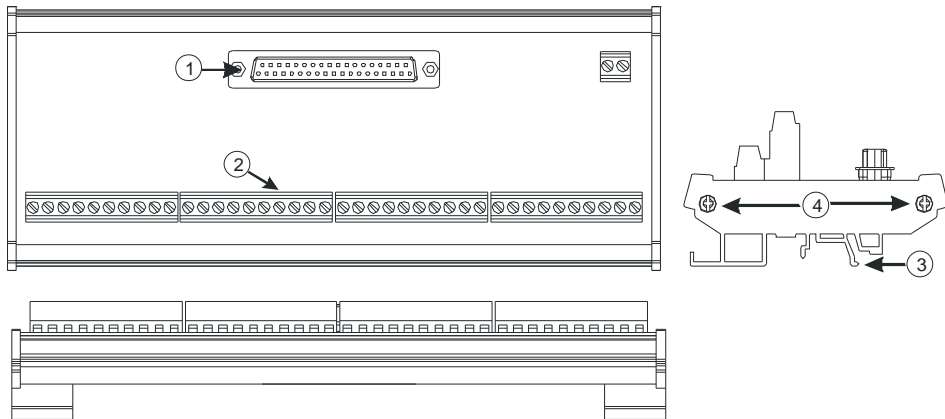

3

◆ DVPAETB-OT32B

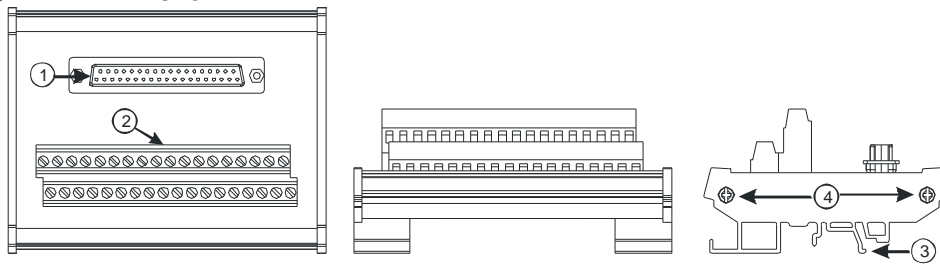

4. External terminal modules for AH32AN02P-5B

◆ DVPAETB-OR32B

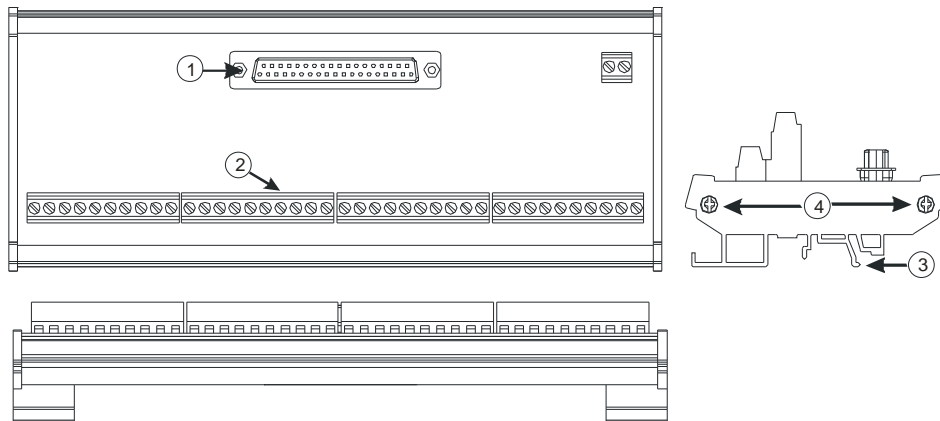

◆ DVPAETB-OT32B

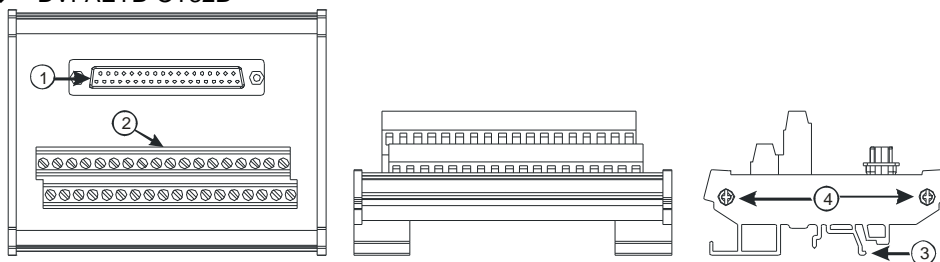

Number	Name	Description
1	DB37 connector	Connecting the external terminal module and a digital input/output module
2	Terminals	Input/Output terminals for wiring
3	Clip	Hanging the external terminal module on a DIN rail
4	Set screw	Fixing the base

3

● **Latch connector, I/O extension cable, and external terminal module**

1. I/O extension cable DVPACAB7A10

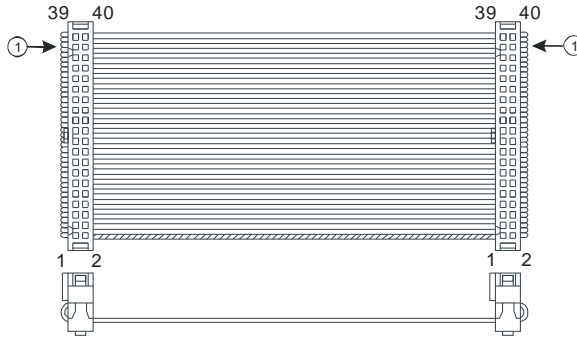

Number	Name	Description
1	40-pin IDC connector	Connecting a digital input/output module and the external terminal module DVPAETB-ID32A.

3

2. External terminal module for AH32AM10N-5C/AH64AM10N-5C: DVPAETB-ID32A

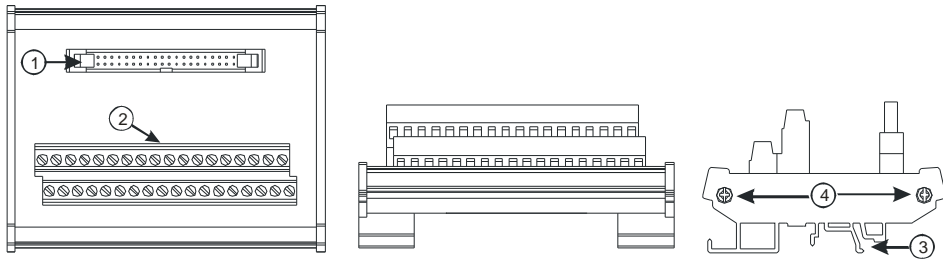

Number	Name	Description
1	40-pin latch connector	Connecting the external terminal module and a digital input/output module
2	Terminals	Input/Output terminals for wiring
3	Clip	Hanging the external terminal module on a DIN rail
4	Set screw	Fixing the base

3. I/O extension cable DVPACAB7B10

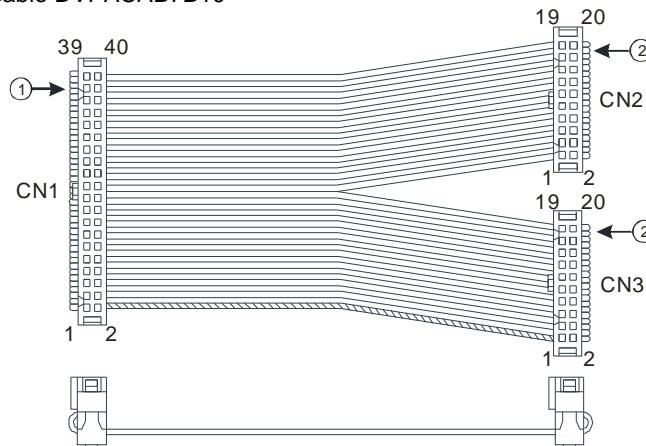

Number	Name	Description
1	40-pin IDC connector	Connecting a digital input/output module and an external terminal module
2	20-pin IDC connector	Connecting a digital input/output module and the external terminal module DVPAETB-OR16A or DVPAETB-OR16B

4. I/O extension cable DVPACAB7A10

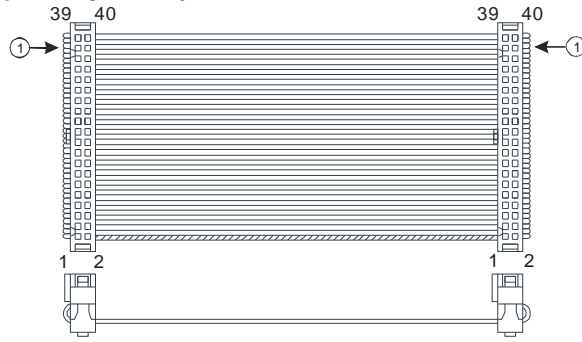

Number	Name	Description
1	40-pin IDC connector	Connecting a digital input/output module and the external terminal module DVPAETB-OT32A

5. External terminal modules for AH32AN02T-5C/AH64AN02T-5C

◆ DVPAETB-OR16A

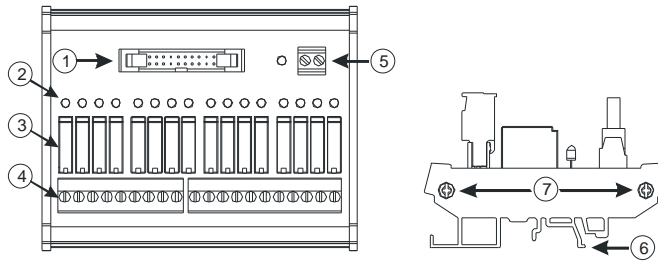

◆ DVPAETB-OT32A

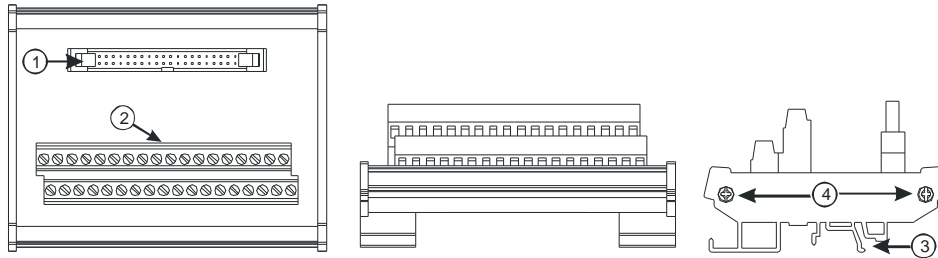

6. External terminal module for AH32AN02P-5C/AH64AN02P-5C

◆ DVPAETB-OR16B

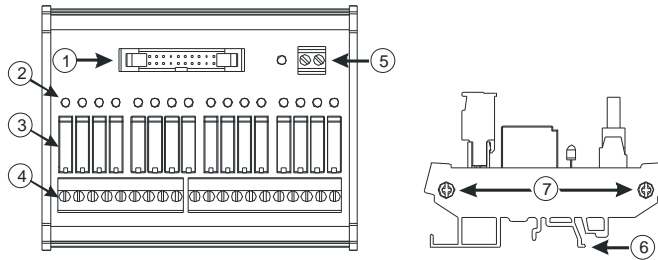

3

◆ DVPAETB-OT32A

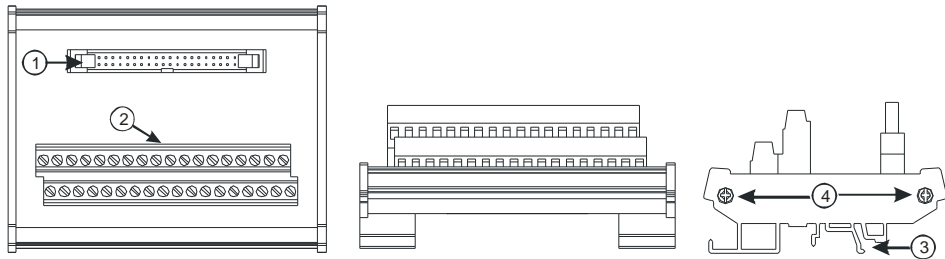

Number	Name	Description
1	20-pin latch connector	Connecting the external terminal module and a digital input/output module
2	Output LED indicator	If there is an output signal, the output LED indicator is ON.
3	Output relay	Output relay
4	Output terminal	Output terminal for wiring
5	Power input terminal	Power input terminal for wiring
6	Clip	Hanging the external terminal module on a DIN rail
7	Set screw	Fixing the base

3

3.5.3 Dimensions

- AH16AM10N-5A/AH16AM30N-5A/AH16AR10N-5A/AH16AN01S-5A/AH16AN01R-5A/AH16AN01T-5A/AH16AN01P-5A/AH16AP11R-5A/AH16AP11T-5A/AH16AP11P-5A

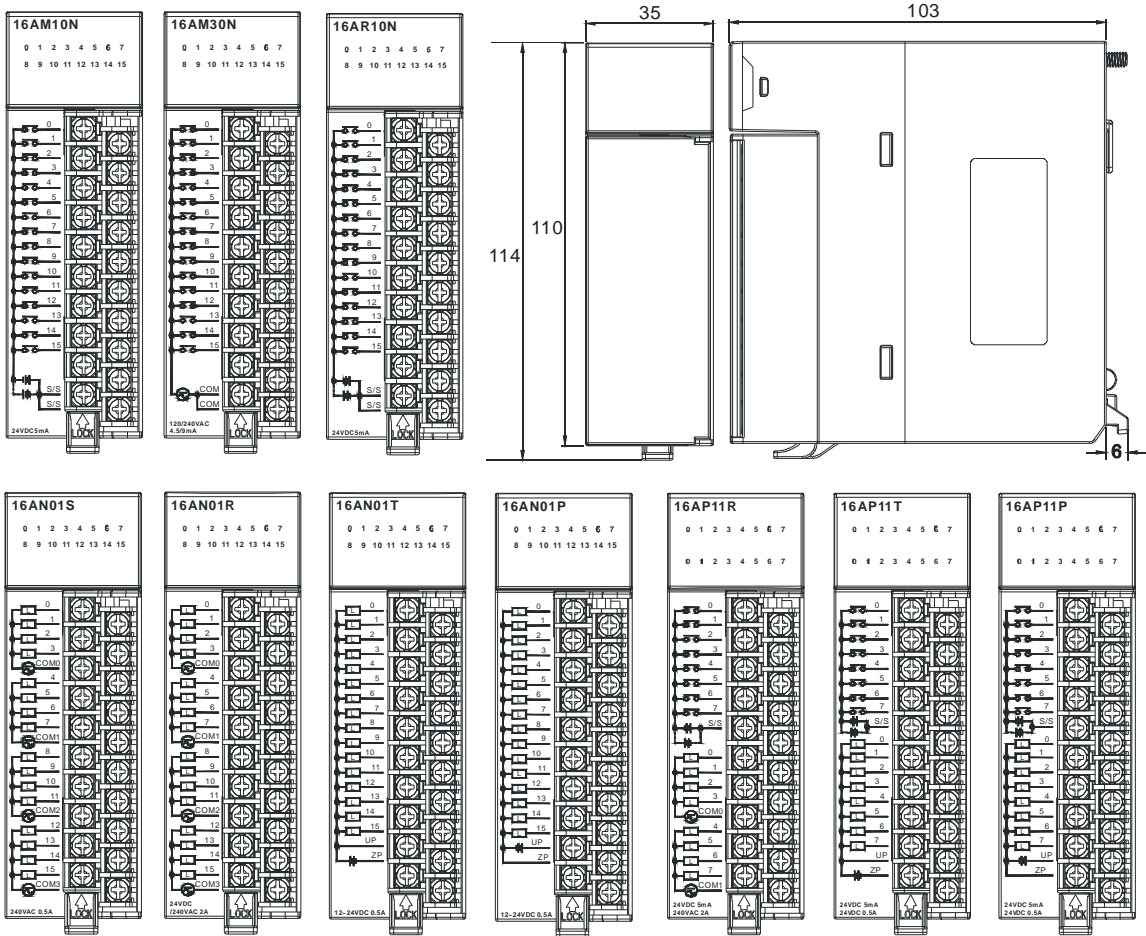

Unit: mm

● AH32AM10N-5A/AH32AN02T-5A/AH32AN02P-5A

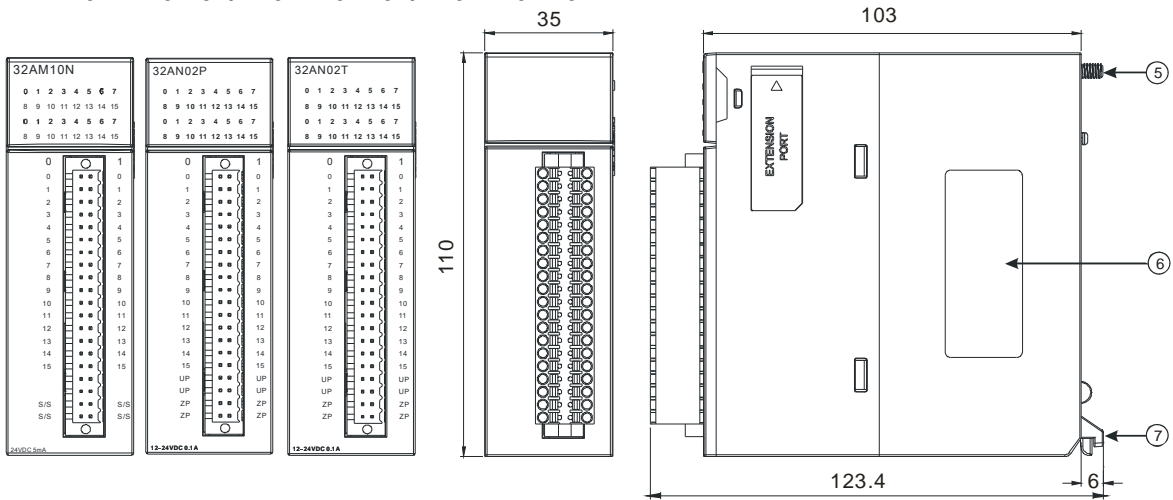

Unit: mm

● AH32AM10N-5B/AH32AN02T-5B/AH32AN02P-5B

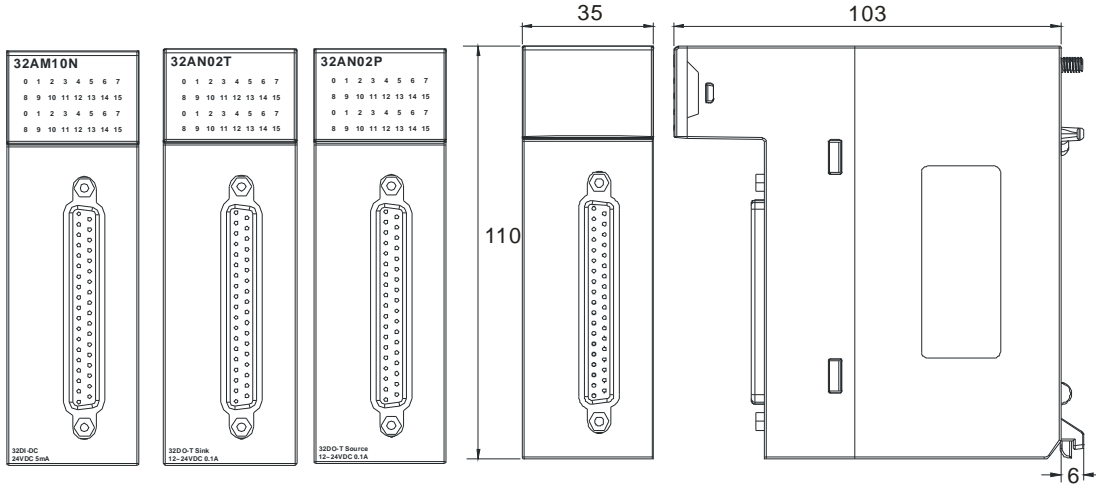

Unit: mm

● AH32AM10N-5C/AH32AN02T-5C/AH32AN02P-5C

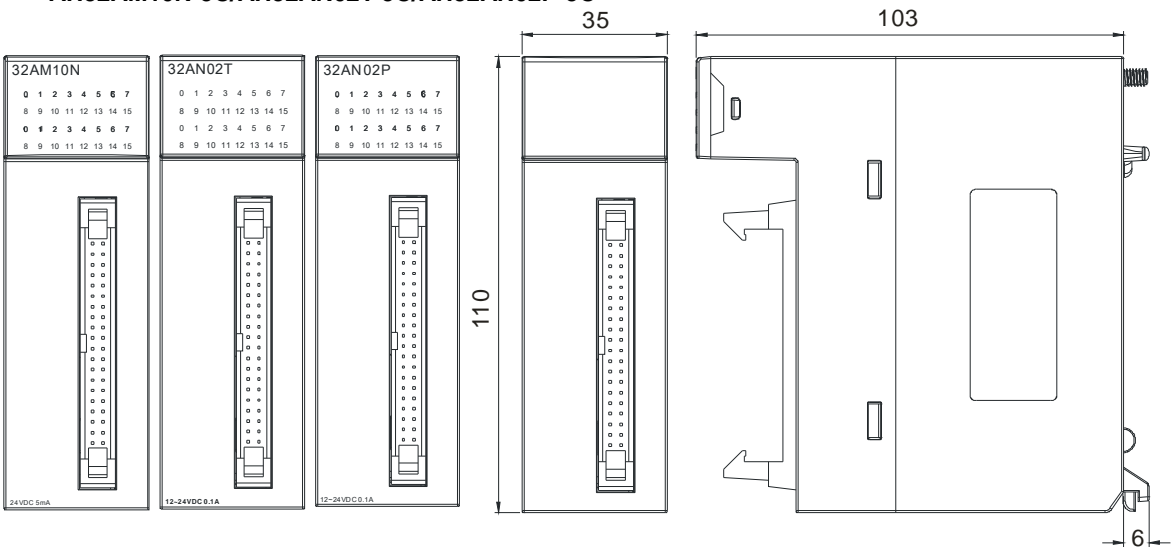

Unit: mm

3

● AH64AM10N-5C/AH64AN02T-5C/AH64AN02P-5C

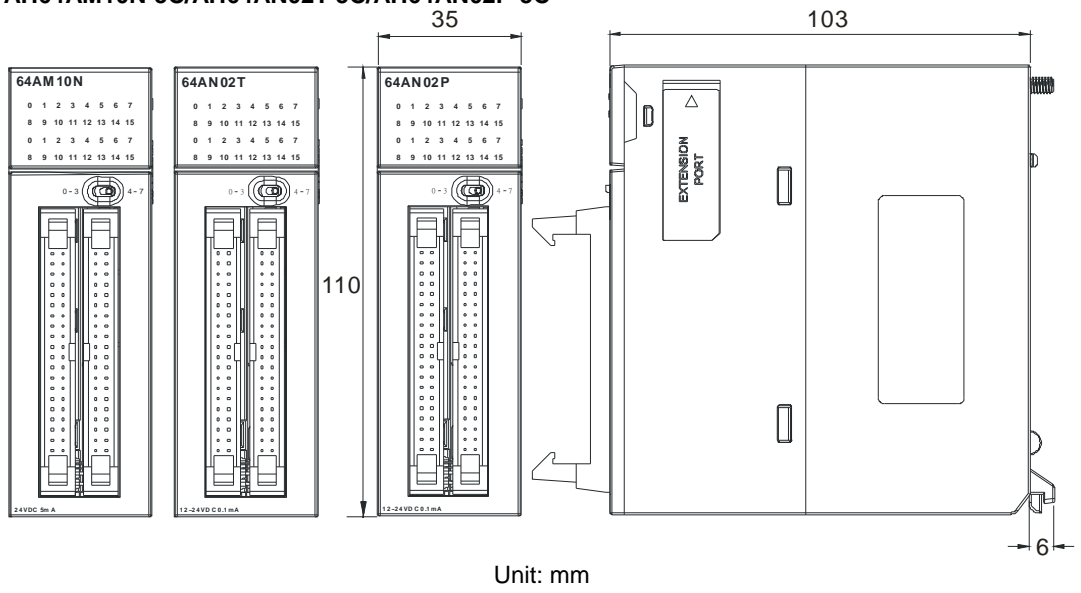

● DB37 connector, I/O extension cable, and external terminal module

1. I/O extension cable DVPACAB7C10

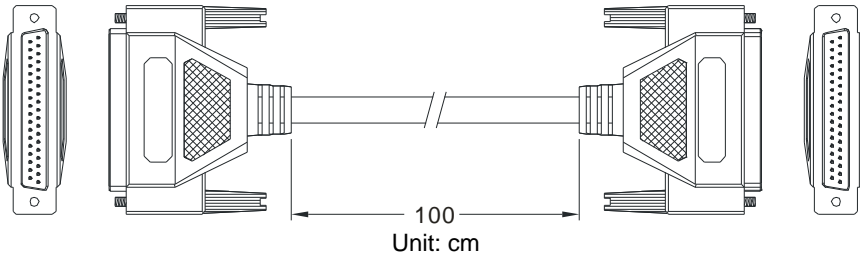

2. External terminal module for AH32AM10N-5B: DVPAETB-ID32B

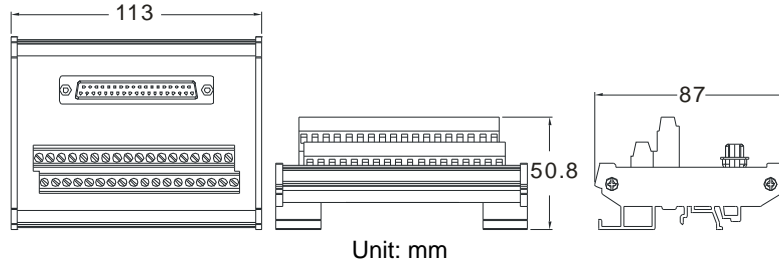

3. External terminal modules for AH32AN02T-5B

◆ DVPAETB-OR32A

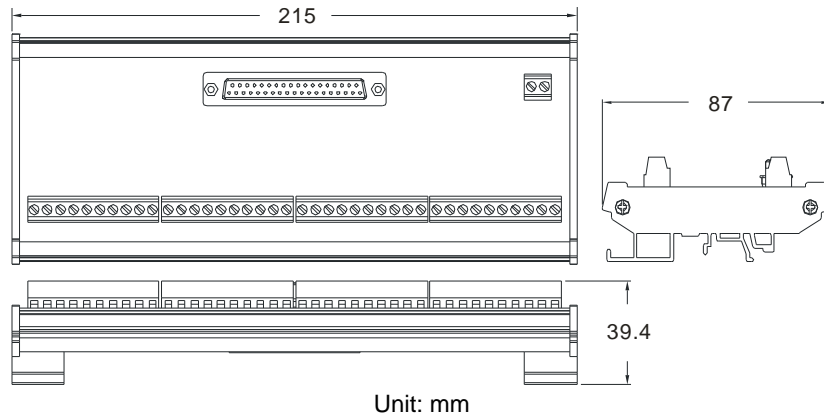

◆ DVPAETB-OT32B

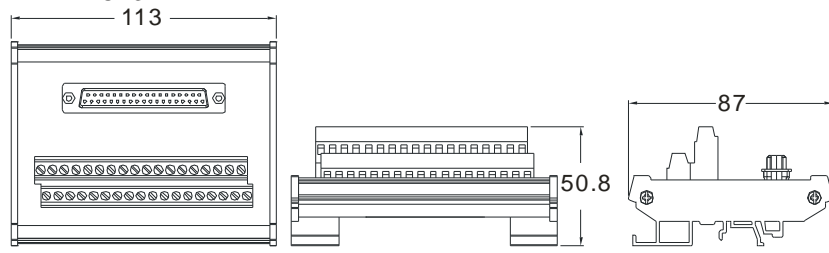

Unit: mm

4. External terminal modules for AH32AN02P-5B

◆ DVPAETB-OR32B

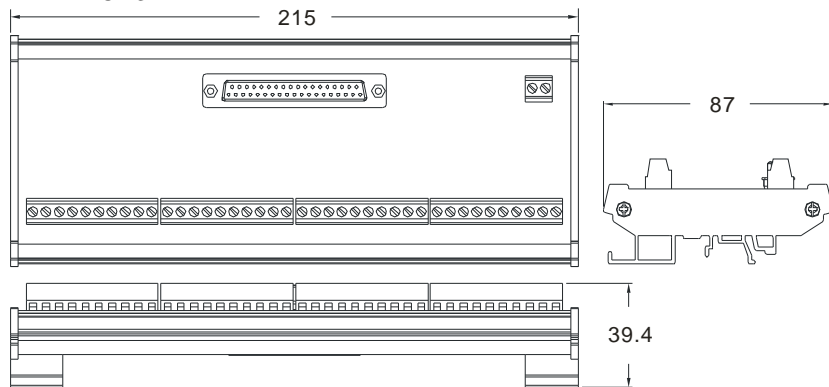

Unit: mm

◆ DVPAETB-OT32B

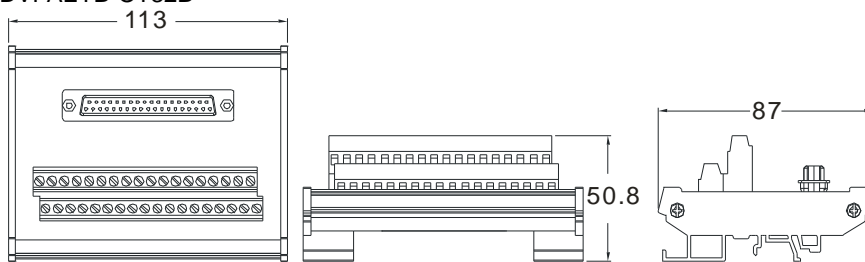

Unit: mm

● Latch connector, I/O extension cable, and external terminal module

1. I/O extension cable DVPACAB7A10

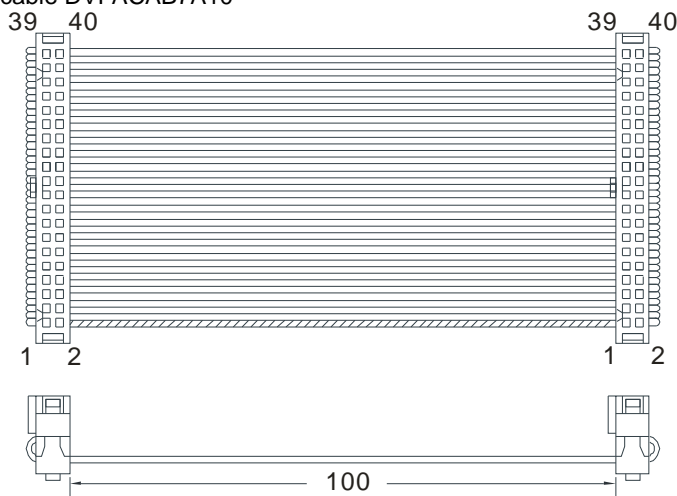

Unit: cm

3

2. External terminal module for AH32AM10N-5C/AH64AM10N-5C: DVPAETB-ID32A

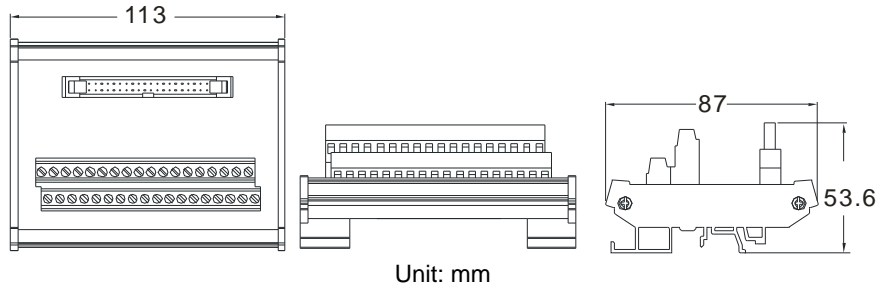

Unit: mm

3. External terminal module for AH32AN02T-5C/AH64AN02T-5C: DVPAETB-OT32A

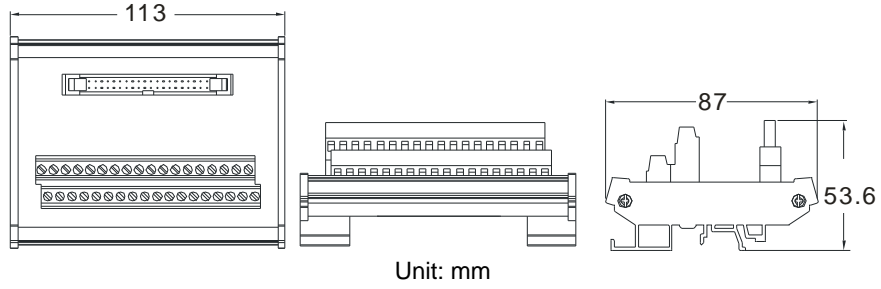

Unit: mm

4. External terminal module for AH32AN02P-5C/AH64AN02P-5C: DVPAETB-OT32A

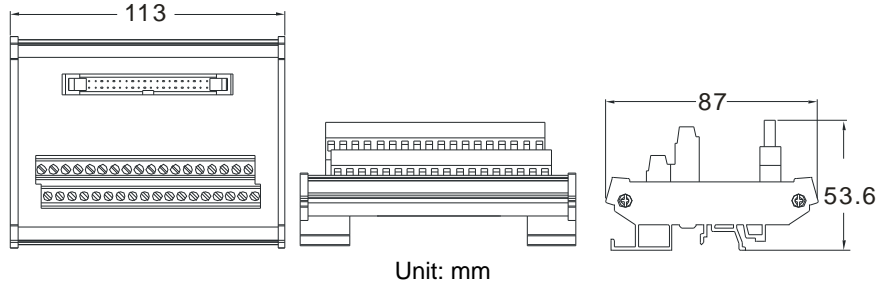

Unit: mm

5. I/O extension cable DVPA CAB7B10

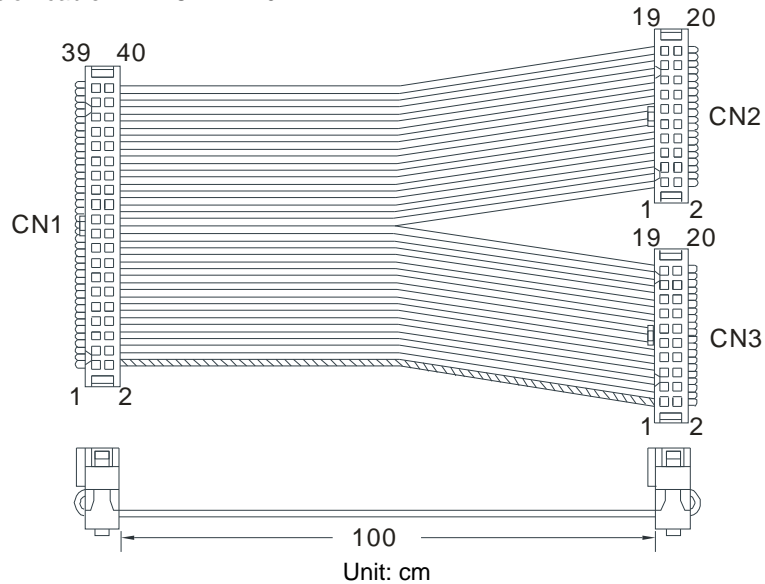

Unit: cm

6. External terminal module for AH32AN02T-5C/AH64AN02T-5C: DVPAETB-OR16A

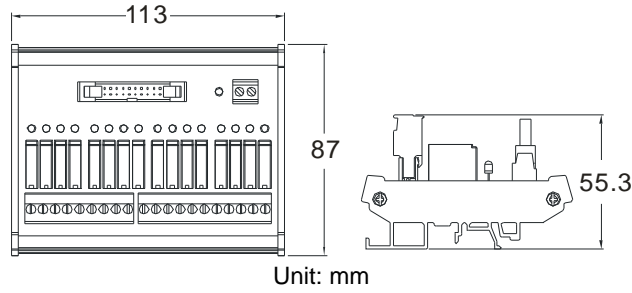

7. External terminal module for AH32AN02P-5C/AH64AN02P-5C: DVPAETB-OR16B

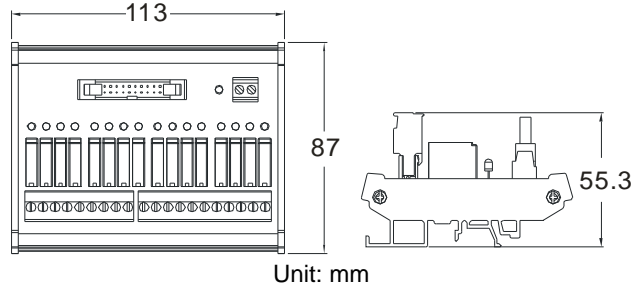

3

3.5.4 Arrangement of Input/Output Terminals

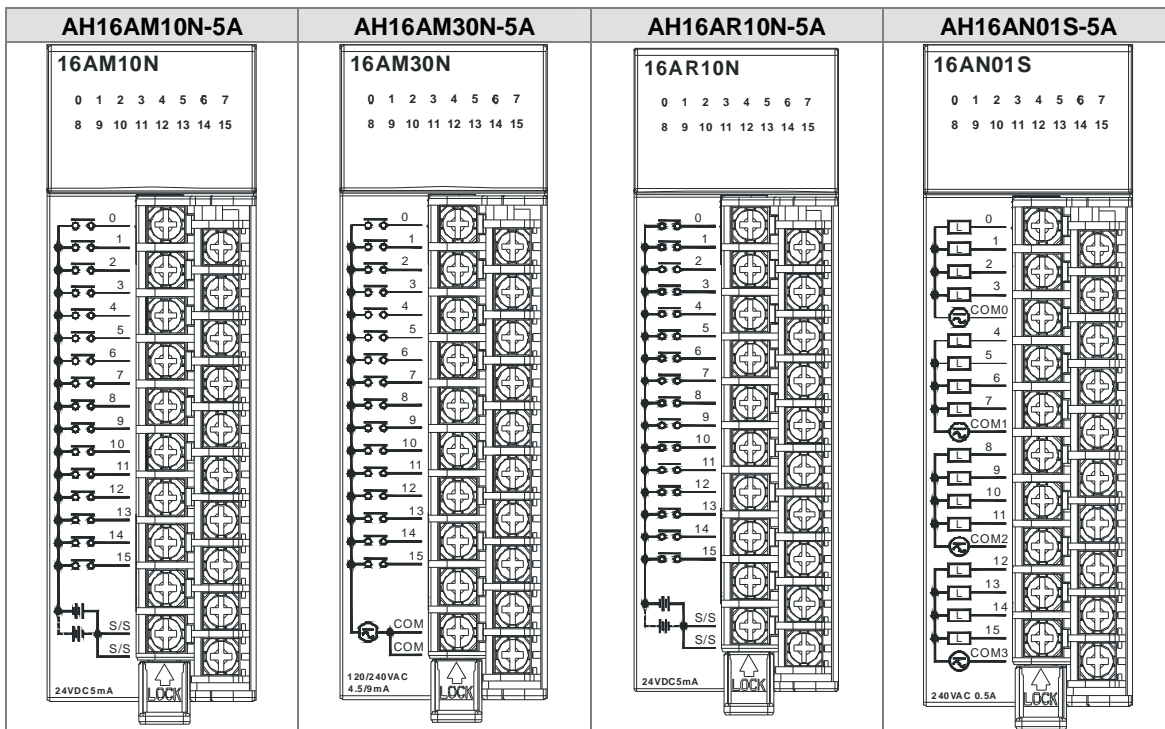

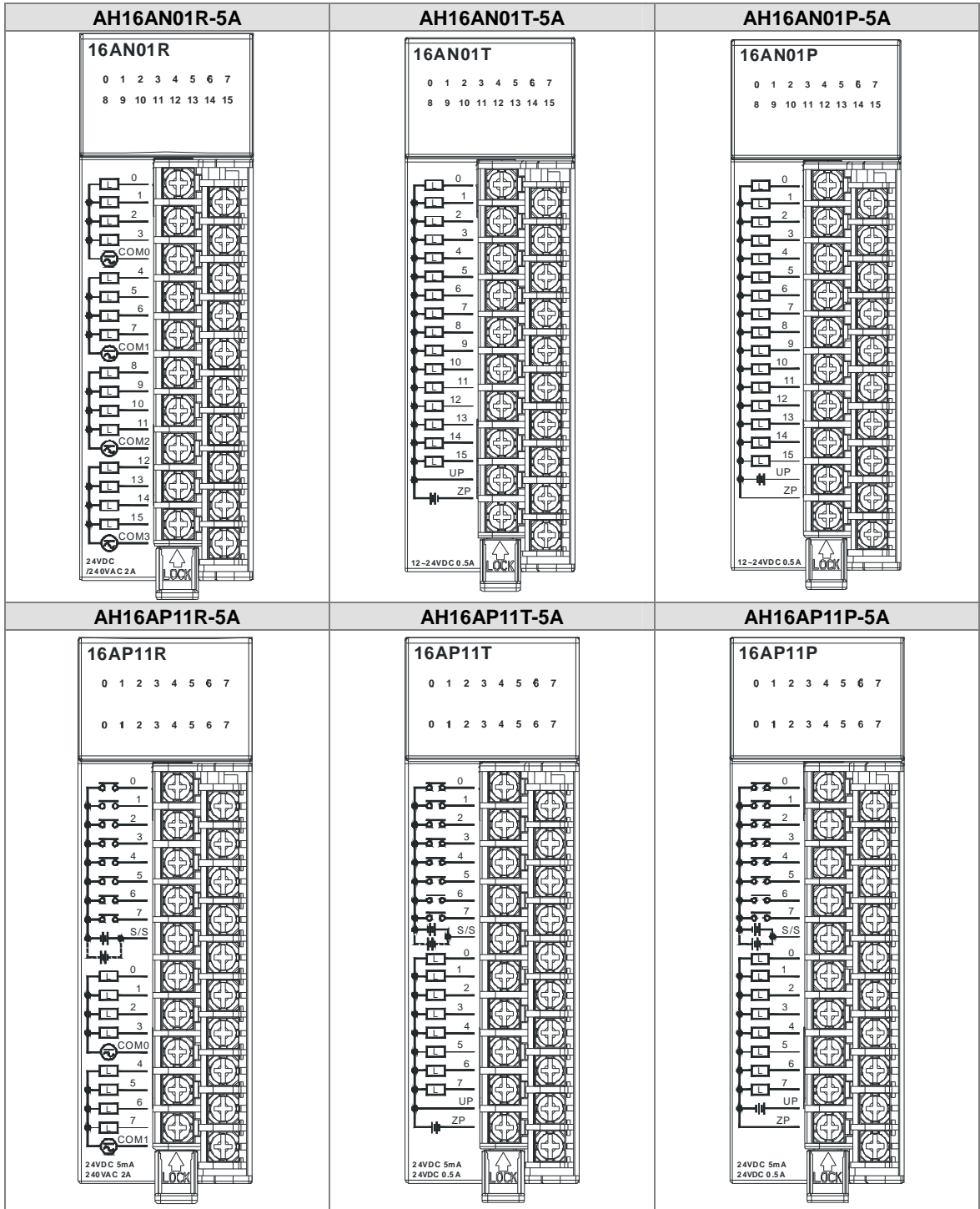

3

3

AH32AM10N-5A			AH32AN02T-5A		
<p>32AM10N</p> <p>0 1 2 3 4 5 6 7 8 9 10 11 12 13 14 15</p> <p>0 1 2 3 4 5 6 7 8 9 10 11 12 13 14 15</p> <p>0 1 0 1 2 2 3 3 4 4 5 5 6 6 7 7 8 8 9 9 10 10 11 11 12 12 13 13 14 14 15 15</p> <p>S/S S/S S/S S/S</p> <p>24VDC 5mA</p>	0.0	1.0	<p>32AN02T</p> <p>0 1 2 3 4 5 6 7 8 9 10 11 12 13 14 15</p> <p>0 1 2 3 4 5 6 7 8 9 10 11 12 13 14 15</p> <p>0 1 0 1 2 2 3 3 4 4 5 5 6 6 7 7 8 8 9 9 10 10 11 11 12 12 13 13 14 14 15 15</p> <p>UP UP UP UP ZP ZP ZP ZP</p> <p>12-24VDC 0.1A</p>	0.0	1.0
	0.1	1.1		0.1	1.1
	0.2	1.2		0.2	1.2
	0.3	1.3		0.3	1.3
	0.4	1.4		0.4	1.4
	0.5	1.5		0.5	1.5
	0.6	1.6		0.6	1.6
	0.7	1.7		0.7	1.7
	0.8	1.8		0.8	1.8
	0.9	1.9		0.9	1.9
	0.10	1.10		0.10	1.10
	0.11	1.11		0.11	1.11
	0.12	1.12		0.12	1.12
	0.13	1.13		0.13	1.13
	0.14	1.14		0.14	1.14
	0.15	1.15		0.15	1.15
	-	-		UP	UP
-	-	UP	UP		
S/S	S/S	ZP	ZP		
S/S	S/S	ZP	ZP		

AH32AN02P-5A			AH32AM10N-5B		
<p>32AN02P</p> <p>0 1 2 3 4 5 6 7 8 9 10 11 12 13 14 15</p> <p>0 1 2 3 4 5 6 7 8 9 10 11 12 13 14 15</p> <p>0 1 0 1 2 2 3 3 4 4 5 5 6 6 7 7 8 8 9 9 10 10 11 11 12 12 13 13 14 14 15 15</p> <p>UP UP UP UP ZP ZP ZP ZP</p> <p>12-24VDC 0.1A</p>	0.0	1.0	<p>32AM10N</p> <p>0 1 2 3 4 5 6 7 8 9 10 11 12 13 14 15</p> <p>0 1 2 3 4 5 6 7 8 9 10 11 12 13 14 15</p> <p>0 1 0 1 2 2 3 3 4 4 5 5 6 6 7 7 8 8 9 9 10 10 11 11 12 12 13 13 14 14 15 15</p> <p>S/S S/S</p> <p>24VDC 5mA</p>	0.0	0.1
	0.1	1.1		0.2	0.3
	0.2	1.2		0.4	0.5
	0.3	1.3		0.6	0.7
	0.4	1.4		0.8	0.9
	0.5	1.5		0.10	0.11
	0.6	1.6		0.12	0.13
	0.7	1.7		0.14	0.15
	0.8	1.8		S/S	S/S
	0.9	1.9		NC	1.0
	0.10	1.10		1.1	1.2
	0.11	1.11		1.3	1.4
	0.12	1.12		1.5	1.6
	0.13	1.13		1.7	1.8
	0.14	1.14		1.9	1.10
	0.15	1.15		1.11	1.12
	UP	UP		1.13	1.14
UP	UP	1.15	S/S		
ZP	ZP	S/S			
ZP	ZP				

AH32AN02T-5B			AH32AN02P-5B		
	0.0	0.1		0.0	0.1
	0.2	0.3		0.2	0.3
	0.4	0.5		0.4	0.5
	0.6	0.7		0.6	0.7
	0.8	0.9		0.8	0.9
	0.10	0.11		0.10	0.11
	0.12	0.13		0.12	0.13
	0.14	0.15		0.14	0.15
	ZP	ZP		ZP	ZP
	UP	1.0		UP	1.0
	1.1	1.2		1.1	1.2
	1.3	1.4		1.3	1.4
	1.5	1.6		1.5	1.6
	1.7	1.8		1.7	1.8
	1.9	1.10		1.9	1.10
	1.11	1.12		1.11	1.12
	1.13	1.14		1.13	1.14
	1.15	ZP		1.15	ZP
	UP			UP	

AH32AM10N-5C			AH32AN02T-5C		
	0.0	0.1		0.0	0.1
	0.2	0.3		0.2	0.3
	0.4	0.5		0.4	0.5
	0.6	0.7		0.6	0.7
	0.8	0.9		0.8	0.9
	0.10	0.11		0.10	0.11
	0.12	0.13		0.12	0.13
	0.14	0.15		0.14	0.15
	S/S	S/S		ZP	ZP
				UP	UP
	1.0	1.1		1.0	1.1
	1.2	1.3		1.2	1.3
	1.4	1.5		1.4	1.5
	1.6	1.7		1.6	1.7
	1.8	1.9		1.8	1.9
	1.10	1.11		1.10	1.11
	1.12	1.13		1.12	1.13
	1.14	1.15		1.14	1.15
	S/S	S/S		ZP	ZP
				UP	UP

3

AH32AN02P-5C			AH64AM10N-5C				
<p>32AN02P 0 1 2 3 4 5 6 7 8 9 10 11 12 13 14 15 0 1 2 3 4 5 6 7 8 9 10 11 12 13 14 15</p> <p>12-24VDC 0.1A</p>	0.0	0.1	<p>64AM 10N 0 1 2 3 4 5 6 7 8 9 10 11 12 13 14 15 0 1 2 3 4 5 6 7 8 9 10 11 12 13 14 15</p> <p>24V DC 5mA</p>	NC	NC	NC	NC
	0.2	0.3		S/S	S/S	2.0	2.1
	0.4	0.5		1.15	1.14	2.2	2.3
	0.6	0.7		1.13	1.12	2.4	2.5
	0.8	0.9		1.11	1.10	2.6	2.7
	0.10	0.11		1.9	1.8	2.8	2.9
	0.12	0.13		1.7	1.6	2.10	2.11
	0.14	0.15		1.5	1.4	2.12	2.13
	ZP	ZP		1.3	1.2	2.14	2.15
	UP	UP		1.1	1.0	S/S	S/S
	1.0	1.1		NC	NC	NC	NC
	1.2	1.3		S/S	S/S	3.0	3.1
	1.4	1.5		0.15	0.14	3.2	3.3
	1.6	1.7		0.13	0.12	3.4	3.5
	1.8	1.9		0.11	0.10	3.6	3.7
	1.10	1.11		0.9	0.8	3.8	3.9
	1.12	1.13		0.7	0.6	3.10	3.11
	1.14	1.15		0.5	0.4	3.12	3.13
	ZP	ZP		0.3	0.2	3.14	3.15
	UP	UP		0.1	0.0	S/S	S/S

AH64AN02T-5C			AH64AN02P-5C						
<p>64AN02T 0 1 2 3 4 5 6 7 8 9 10 11 12 13 14 15 0 1 2 3 4 5 6 7 8 9 10 11 12 13 14 15</p> <p>12-24VDC 0.1mA</p>	UP	UP	2.0	2.1	<p>64AN02P 0 1 2 3 4 5 6 7 8 9 10 11 12 13 14 15 0 1 2 3 4 5 6 7 8 9 10 11 12 13 14 15</p> <p>12-24VDC 0.1mA</p>	UP	UP	2.0	2.1
	ZP	ZP	2.2	2.3		ZP	ZP	2.2	2.3
	1.15	1.14	2.4	2.5		1.15	1.14	2.4	2.5
	1.13	1.12	2.6	2.7		1.13	1.12	2.6	2.7
	1.11	1.10	2.8	2.9		1.11	1.10	2.8	2.9
	1.9	1.8	2.10	2.11		1.9	1.8	2.10	2.11
	1.7	1.6	2.12	2.13		1.7	1.6	2.12	2.13
	1.5	1.4	2.14	2.15		1.5	1.4	2.14	2.15
	1.3	1.2	ZP	ZP		1.3	1.2	ZP	ZP
	1.1	1.0	UP	UP		1.1	1.0	UP	UP
	UP	UP	3.0	3.1		UP	UP	3.0	3.1
	ZP	ZP	3.2	3.3		ZP	ZP	3.2	3.3
	0.15	0.14	3.4	3.5		0.15	0.14	3.4	3.5
	0.13	0.12	3.6	3.7		0.13	0.12	3.6	3.7
	0.11	0.10	3.8	3.9		0.11	0.10	3.8	3.9
	0.9	0.8	3.10	3.11		0.9	0.8	3.10	3.11
	0.7	0.6	3.12	3.13		0.7	0.6	3.12	3.13
	0.5	0.4	3.14	3.15		0.5	0.4	3.14	3.15
	0.3	0.2	ZP	ZP		0.3	0.2	ZP	ZP
	0.1	0.0	UP	UP		0.1	0.0	UP	UP

● **DB37 connector and the external terminal module**

1. External terminal module for AH32AM10N-5B: DVPAETB-ID32B

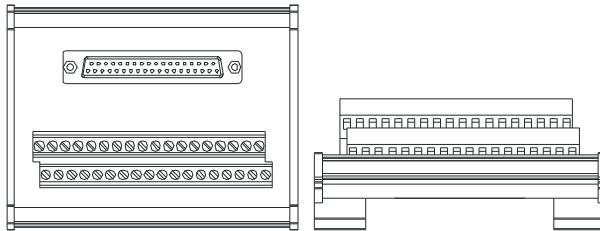

Terminals:

Upper row	X0	X2	X4	X6	X10	X12	X14	X16	X20	X22	X24	X26	X30	X32	X34	X36	S/S	S/S
Lower row	X1	X3	X5	X7	X11	X13	X15	X17	X21	X23	X25	X27	X31	X33	X35	X37	S/S	S/S

AH500 series terminals:

Upper row	X0.0	X0.2	X0.4	X0.6	X0.8	X0.10	X0.12	X0.14	X1.0	X1.2	X1.4	X1.6	X1.8	X1.10	X1.12	X1.14	S/S	S/S
Lower row	X0.1	X0.3	X0.5	X0.7	X0.9	X0.11	X0.13	X0.15	X1.1	X1.3	X1.5	X1.7	X1.9	X1.11	X1.13	X1.15	S/S	S/S

2. External terminal modules for AH32AN02T-5B

◆ DVPAETB-OT32B

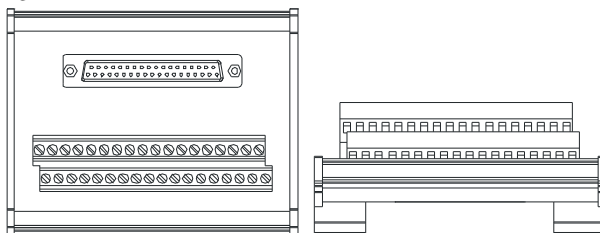

Terminals:

Upper row	Y0	Y2	Y4	Y6	Y10	Y12	Y14	Y16	Y20	Y22	Y24	Y26	Y30	Y32	Y34	Y36	UP	UP
Lower row	Y1	Y3	Y5	Y7	Y11	Y13	Y15	Y17	Y21	Y23	Y25	Y27	Y31	Y33	Y35	Y37	ZP	ZP

AH500 series terminals:

Upper row	Y0.0	Y0.2	Y0.4	Y0.6	Y0.8	Y0.10	Y0.12	Y0.14	Y1.0	Y1.2	Y1.4	Y1.6	Y1.8	Y1.10	Y1.12	Y1.14	UP	UP
Lower row	Y0.1	Y0.3	Y0.5	Y0.7	Y0.9	Y0.11	Y0.13	Y0.15	Y1.1	Y1.3	Y1.5	Y1.7	Y1.9	Y1.11	Y1.13	Y1.15	ZP	ZP

◆ DVPAETB-OR32A

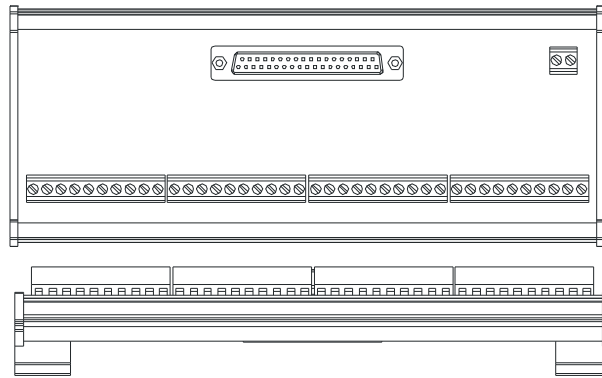

Terminals:

																						GND	+24V
1st from the left	C0	Y0	Y1	Y2	Y3	C1	Y4	Y5	Y6	Y7	C2	Y10	Y11	Y12	Y13	C3	Y14	Y15	Y16	Y17			
21st from the left	C4	Y20	Y21	Y22	Y23	C5	Y24	Y25	Y26	Y27	C6	Y30	Y31	Y32	Y33	C7	Y34	Y35	Y36	Y37			

AH500 series terminals:

																								GND	+24V
1st from the left	C0	Y0.0	Y0.1	Y0.2	Y0.3	C1	Y0.4	Y0.5	Y0.6	Y0.7	C2	Y0.8	Y0.9	Y0.10	Y0.11	C3	Y0.12	Y0.13	Y0.14	Y0.15					
21st from the left	C4	Y1.0	Y1.1	Y1.2	Y1.3	C5	Y1.4	Y1.5	Y1.6	Y1.7	C6	Y1.8	Y1.9	Y1.10	Y1.11	C7	Y1.12	Y1.13	Y1.14	Y1.15					

3. External terminal modules for AH32AN02P-5B

◆ DVPAETB-OT32B

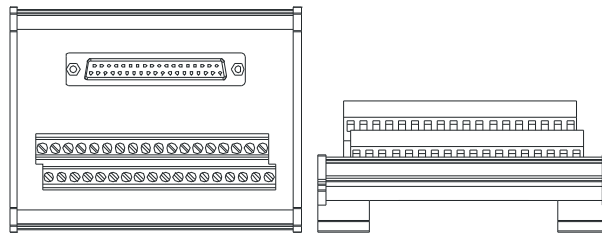

Terminals:

Upper row	Y0	Y2	Y4	Y6	Y10	Y12	Y14	Y16	Y20	Y22	Y24	Y26	Y30	Y32	Y34	Y36	UP	UP
Lower row	Y1	Y3	Y5	Y7	Y11	Y13	Y15	Y17	Y21	Y23	Y25	Y27	Y31	Y33	Y35	Y37	ZP	ZP

AH500 series terminals:

Upper row	Y0.0	Y0.2	Y0.4	Y0.6	Y0.8	Y0.10	Y0.12	Y0.14	Y1.0	Y1.2	Y1.4	Y1.6	Y1.8	Y1.10	Y1.12	Y1.14	UP	UP
Lower row	Y0.1	Y0.3	Y0.5	Y0.7	Y0.9	Y0.11	Y0.13	Y0.15	Y1.1	Y1.3	Y1.5	Y1.7	Y1.9	Y1.11	Y1.13	Y1.15	ZP	ZP

◆ DVPAETB-OR32B

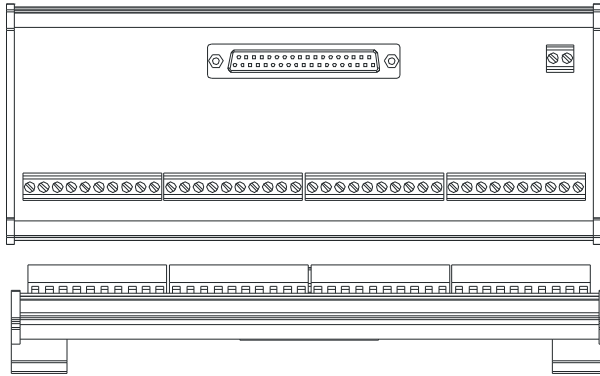

Terminals:

																			GND	+24V
1st from the left	C0	Y0	Y1	Y2	Y3	C1	Y4	Y5	Y6	Y7	C2	Y10	Y11	Y12	Y13	C3	Y14	Y15	Y16	Y17
21st from the left	C4	Y20	Y21	Y22	Y23	C5	Y24	Y25	Y26	Y27	C6	Y30	Y31	Y32	Y33	C7	Y34	Y35	Y36	Y37

AH500 series terminals:

																				GND	+24V
1st from the left	C0	Y0.0	Y0.1	Y0.2	Y0.3	C1	Y0.4	Y0.5	Y0.6	Y0.7	C2	Y0.8	Y0.9	Y0.10	Y0.11	C3	Y0.12	Y0.13	Y0.14	Y0.15	
21st from the left	C4	Y1.0	Y1.1	Y1.2	Y1.3	C5	Y1.4	Y1.5	Y1.6	Y1.7	C6	Y1.8	Y1.9	Y1.10	Y1.11	C7	Y1.12	Y1.13	Y1.14	Y1.15	

● Latch connector and external terminal module

- External terminal module for AH32AM10N-5C/AH64AM10N-5C: DVPAETB-ID32A

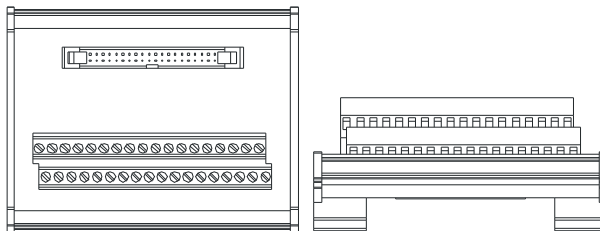

Terminals:

Upper row	S/S	S/S	X0	X2	X4	X6	X10	X12	X14	X16	X20	X22	X24	X26	X30	X32	X34	X36
Lower row	S/S	S/S	X1	X3	X5	X7	X11	X13	X15	X17	X21	X23	X25	X27	X31	X33	X35	X37

AH500 series terminals:

Upper row	X0.0	X0.2	X0.4	X0.6	X0.8	X0.10	X0.12	X0.14	X1.0	X1.2	X1.4	X1.6	X1.8	X1.10	X1.12	X1.14	S/S	S/S
Lower row	X0.1	X0.3	X0.5	X0.7	X0.9	X0.11	X0.13	X0.15	X1.1	X1.3	X1.5	X1.7	X1.9	X1.11	X1.13	X1.15	S/S	S/S

2. External terminal modules for AH32AN02T-5C/AH64AN02T-5C:

◆ DVPAETB-OT32A

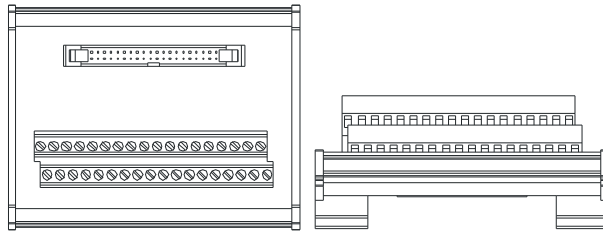

Terminals:

Upper row	Y0	Y2	Y4	Y6	Y10	Y12	Y14	Y16	Y20	Y22	Y24	Y26	Y30	Y32	Y34	Y36	+24V	+24V
Lower row	Y1	Y3	Y5	Y7	Y11	Y13	Y15	Y17	Y21	Y23	Y25	Y27	Y31	Y33	Y35	Y37	GND	GND

AH500 series terminals:

Upper row	Y0.0	Y0.2	Y0.4	Y0.6	Y0.8	Y0.10	Y0.12	Y0.14	Y1.0	Y1.2	Y1.4	Y1.6	Y1.8	Y1.10	Y1.12	Y1.14	+24V	+24V
Lower row	Y0.1	Y0.3	Y0.5	Y0.7	Y0.9	Y0.11	Y0.13	Y0.15	Y1.1	Y1.3	Y1.5	Y1.7	Y1.9	Y1.11	Y1.13	Y1.15	GND	GND

◆ DVPAETB-OR16A

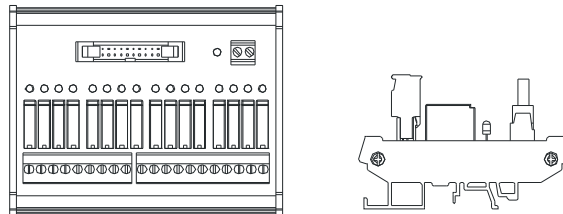

Terminals:

																			GND	+24V
C0	Y0	Y1	Y2	Y3	C1	Y4	Y5	Y6	Y7	C2	Y10	Y11	Y12	Y13	C3	Y14	Y15	Y16	Y17	

AH500 series terminals:

																				GND	+24V
C0	Y0.0	Y0.1	Y0.2	Y0.3	C1	Y0.4	Y0.5	Y0.6	Y0.7	C2	Y0.8	Y0.9	Y0.10	Y0.11	C3	Y0.12	Y0.13	Y0.14	Y0.15		

3

3. External terminal module for AH32AN02P-5C/AH64AN02P-5C:

◆ DVPAETB-OT32A

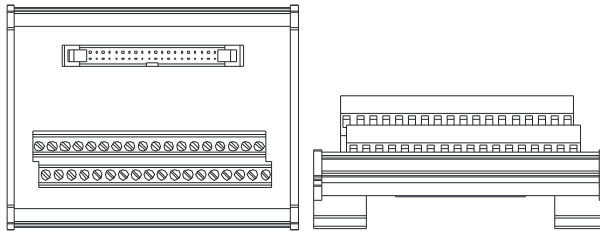

Terminals:

Upper row	Y0	Y2	Y4	Y6	Y10	Y12	Y14	Y16	Y20	Y22	Y24	Y26	Y30	Y32	Y34	Y36	+24V	+24V
Lower row	Y1	Y3	Y5	Y7	Y11	Y13	Y15	Y17	Y21	Y23	Y25	Y27	Y31	Y33	Y35	Y37	GND	GND

AH500 series terminals:

Upper row	Y0.0	Y0.2	Y0.4	Y0.6	Y0.8	Y0.10	Y0.12	Y0.14	Y1.0	Y1.2	Y1.4	Y1.6	Y1.8	Y1.10	Y1.12	Y1.14	+24V	+24V
Lower row	Y0.1	Y0.3	Y0.5	Y0.7	Y0.9	Y0.11	Y0.13	Y0.15	Y1.1	Y1.3	Y1.5	Y1.7	Y1.9	Y1.11	Y1.13	Y1.15	GND	GND

◆ DVPAETB-OR16B

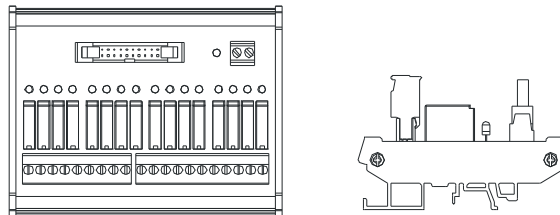

Terminals:

																		GND	+24V
C0	Y0	Y1	Y2	Y3	C1	Y4	Y5	Y6	Y7	C2	Y10	Y11	Y12	Y13	C3	Y14	Y15	Y16	Y17

AH500 series terminals:

																			GND	+24V
C0	Y0.0	Y0.1	Y0.2	Y0.3	C1	Y0.4	Y0.5	Y0.6	Y0.7	C2	Y0.8	Y0.9	Y0.10	Y0.11	C3	Y0.12	Y0.13	Y0.14	Y0.15	

3.6 Specifications for Analog Input/Output Modules

3.6.1 General Specifications

- AH04AD-5A/AH08AD-5B/AH08AD-5C

Electrical specifications

Module name	AH04AD-5A	AH08AD-5B	AH08AD-5C
Number of inputs	4	8	8
Analog-to-digital conversion	Voltage input/Current input	Voltage input	Current input
Supply voltage	24 V DC (20.4 V DC~28.8 V DC) (-15%~+20%)		
Connector type	Removable terminal block		
Conversion time	150 μ s/channel		
Isolation	An analog circuit is isolated from a digital circuit by a digital integrated circuit/an optocoupler, but the analog channels are not isolated from one another. Isolation between a digital circuit and a ground: 500 V DC Isolation between an analog circuit and a ground: 500 V DC Isolation between an analog circuit and a digital circuit: 500 V DC Isolation between the 24 V DC and a ground: 500 V DC		

Functional specifications

Analog-to-digital conversion	Voltage input				
Rated input range	-10 V~10 V	0 V~10 V	± 5 V	0 V~5 V	1 V~5 V
Hardware input range	-10.1 V~10.1 V	-0.1 V~10.1 V	-5.05 V~5.05 V	-0.05 V~5.05 V	0.95 V~5.05 V
Fiducial error (Room temperature) (The number of input voltages which are averaged is 100.)	$\pm 0.1\%$				
Fiducial error (Full temperature range) (The number of input voltages which are averaged is 100.)	$\pm 0.45\%$				
Linearity error (Room temperature)	$\pm 0.07\%$				
Linearity error (Full temperature range)	$\pm 0.12\%$				
Hardware resolution	16 bits				
Input impedance	>200 k Ω				
Absolute input range	± 15 V				

Analog-to-digital conversion	Current input		
Rated input range	± 20 mA	0 mA~20 mA	4 mA~20 mA
Hardware input range	-20.2 mA~20.2 mA	-0.2 mA~20.2 mA	3.8 mA~20.2 mA

Analog-to-digital conversion	Current input
Fiducial error (Room temperature) (The number of input currents which are averaged is 100.)	±0.1%
Fiducial error (Full temperature range) (The number of input currents which are averaged is 100.)	±0.2%
Linearity error (Room temperature) (Full temperature range)	±0.05%
Linearity error	±0.23%
Hardware resolution	16 bits
Input impedance	250 Ω
Absolute input range	±32 mA

● AH04DA-5A/AH08DA-5B/AH08DA-5C

Electrical specifications

Module name	AH04DA-5A	AH08DA-5B	AH08DA-5C
Number of outputs	4	8	8
Analog-to-digital conversion	Voltage output/ Current output	Voltage output	Current output
Supply voltage	24 V DC (20.4 V DC~28.8 V DC) (-15%~+20%)		
Connector type	Removable terminal block		
Conversion time	150 μs/channel		
Isolation	An analog circuit is isolated from a digital circuit by a digital integrated circuit/an optocoupler, but the analog channels are not isolated from one another. Isolation between a digital circuit and a ground: 500 V DC Isolation between an analog circuit and a ground: 500 V DC Isolation between an analog circuit and a digital circuit: 500 V DC Isolation between the 24 V DC and a ground: 500 V DC		

Functional specifications

Analog-to-digital conversion	Voltage output				
Rated output range	±10 V	0 V~10 V	±5 V	0 V~5 V	1 V~5 V
Hardware output range	-10.1 V~10.1 V	-0.1 V~10.1 V	-5.05 V~5.05 V	-0.05 V~5.05 V	0.95 V~5.05 V

3

Analog-to-digital conversion	Voltage output	
Fiducial error (Room temperature) (The number of output voltages which are averaged is 100.)	$\pm 0.02\%$	
Fiducial error (Full temperature range) (The number of output voltages which are averaged is 100.)	$\pm 0.04\%$	
Linearity error (Room temperature)	$\pm 0.004\%$	
Linearity error (Full temperature range)	$\pm 0.004\%$	
Hardware resolution	16 bits	
Permissible load impedance	1 k Ω ~2 M Ω : ± 10 V and 0 V~10 V $\geq 500 \Omega$: 1 V~5 V	

Analog-to-digital conversion	Current output	
Rated output range	0 mA~20 mA	4 mA~20 mA
Hardware output range	-0.2 mA~20.2 mA	3.8 mA~20.2 mA
Fiducial error (Room temperature) (The number of output currents which are averaged is 100.)	$\pm 0.06\%$	
Fiducial error (Full temperature range) (The number of output currents which are averaged is 100.)	$\pm 0.07\%$	
Linearity error (Room temperature)	$\pm 0.01\%$	
Linearity error (Full temperature range)	$\pm 0.01\%$	
Hardware resolution	16 bits	
Permissible load impedance	$\leq 550 \Omega$	

● AH06XA-5A

Electrical specifications

Module name	AH06XA-5A
Number of inputs	4
Number of outputs	2
Analog-to-digital conversion	Voltage input/Current input/Voltage output/Current output
Supply voltage	24 V DC (20.4 V DC~28.8 V DC) (-15%~+20%)
Connector type	Removable terminal block
Conversion time	150 us/channel
Isolation	An analog circuit is isolated from a digital circuit by a digital integrated circuit/an optocoupler, but the analog channels are not isolated from one another. Isolation between a digital circuit and a ground: 500 V DC Isolation between an analog circuit and a ground: 500 V DC Isolation between an analog circuit and a digital circuit: 500 V DC Isolation between the 24 V DC and a ground: 500 V DC

3

Functional specifications for the analog-to-digital conversion

Analog-to-digital conversion	Voltage input				
	Rated input range	-10 V~10 V	0 V~10 V	±5 V	0 V~5 V
Hardware input range	-10.1 V~10.1 V	-0.1 V~10.1 V	-5.05 V~5.05 V	-0.05 V~5.05 V	0.95 V~5.05 V
Fiducial error (Room temperature) (The number of input voltages which are averaged is 100.)	±0.1%				
Fiducial error (Full temperature range) (The number of input voltages which are averaged is 100.)	±0.45%				
Linearity error (Room temperature)	±0.07%				
Linearity error (Full temperature range)	±0.12%				
Hardware resolution	16 bits				
Input impedance	>200 kΩ				
Absolute input range	±15 V				

Analog-to-digital conversion	Current input		
	Rated input range	±20 mA	0 mA~20 mA
Hardware input range	-20.2 mA~20.2 mA	-0.2 mA~20.2 mA	3.8 mA~20.2 mA

Analog-to-digital conversion	Current input
Fiducial error (Room temperature) (The number of input currents which are averaged is 100.)	$\pm 0.1\%$
Fiducial error (Full temperature range) (The number of input currents which are averaged is 100.)	$\pm 0.2\%$
Linearity error (Room temperature)	$\pm 0.05\%$
Linearity error (Full temperature range)	$\pm 0.23\%$
Hardware resolution	16 bits
Input impedance	250 Ω
Absolute input range	± 32 mA

Functional specifications for the digital-to-analog conversion

Digital-to-analog conversion	Voltage output				
Rated output range	± 10 V	0 V~10 V	± 5 V	0 V~5 V	1 V~5 V
Hardware output range	-10.1 V~10.1 V	-0.1 V~10.1 V	-5.05 V~5.05 V	-0.05 V~5.05 V	0.95 V~5.05 V
Fiducial error (Room temperature) (The number of output voltages which are averaged is 100.)	$\pm 0.02\%$				
Fiducial error (Full temperature range) (The number of output voltages which are averaged is 100.)	$\pm 0.04\%$				
Linearity error (Room temperature)	$\pm 0.004\%$				
Linearity error (Full temperature range)	$\pm 0.004\%$				
Hardware resolution	16 bits				
Permissible load impedance	1 k Ω ~2 M Ω : ± 10 V and 0 V~10 V ≥ 500 Ω : 1 V~5 V				

Digital-to-analog conversion	Current output	
Rated output range	0 mA~20 mA	4 mA~20 mA
Hardware output range	-0.2 mA~20.2 mA	3.8 mA~20.2 mA
Fiducial error (Room temperature) (The number of output currents which are averaged is 100.)	±0.06%	
Fiducial error (Full temperature range) (The number of output currents which are averaged is 100.)	±0.07%	
Linearity error (Room temperature)	±0.01%	
Linearity error (Full temperature range)	±0.01%	
Hardware resolution	16 bits	
Permissible load impedance	≤ 550 Ω	

3.6.2 Profiles

- AH04AD-5A/AH08AD-5B/AH08AD-5C/AH04DA-5A/AH08DA-5B/AH08DA-5C/AH06XA-5A

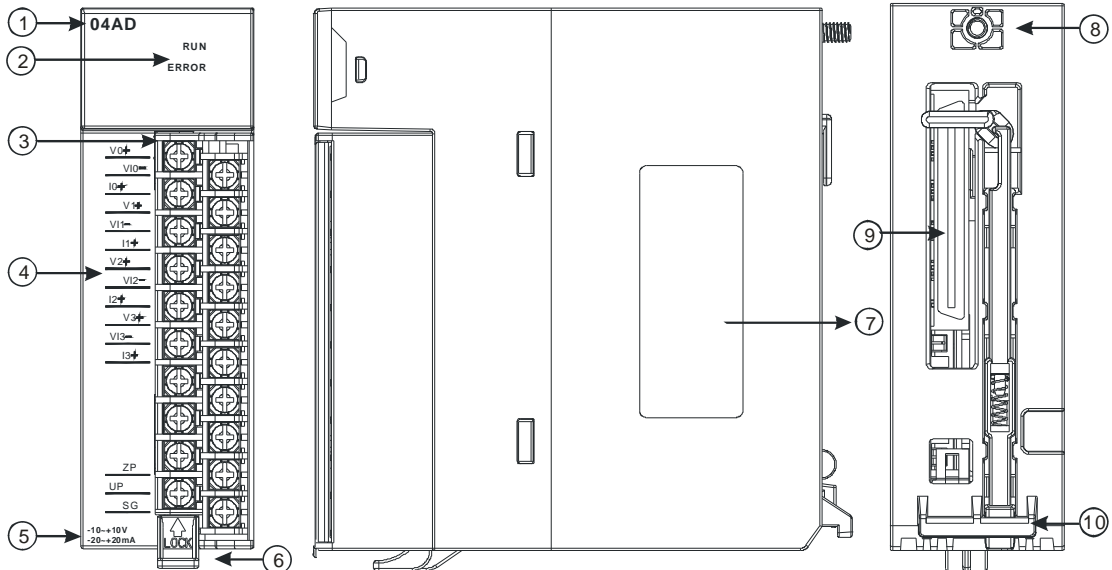

Number	Name	Description
1	Model name	Model name of the module
2	RUN LED indicator	Operating status of the module ON: The module is running. OFF: The module stops running.

Number	Name	Description
2	ERROR LED indicator	Error status of the module ON: A serious error occurs in the module. OFF: The module is normal. Blinking: A slight error occurs in the module.
3	Removable terminal block	The inputs are connected to sensors. The outputs are connected to loads which will be driven.
4	Arrangement of the input/output terminals	Arrangement of the terminals
5	Description of the inputs/outputs	Simple specifications for the module
6	Clip	Removing the terminal block
7	Label	Nameplate
8	Set screw	Fixing the module
9	Connector	Connecting the module and a backplane
10	Projection	Fixing the module

3.6.3 Dimensions

- AH04AD-5A/AH08AD-5B/AH08AD-5C/AH04DA-5A/AH08DA-5B/AH08DA-5C/AH06XA-5A

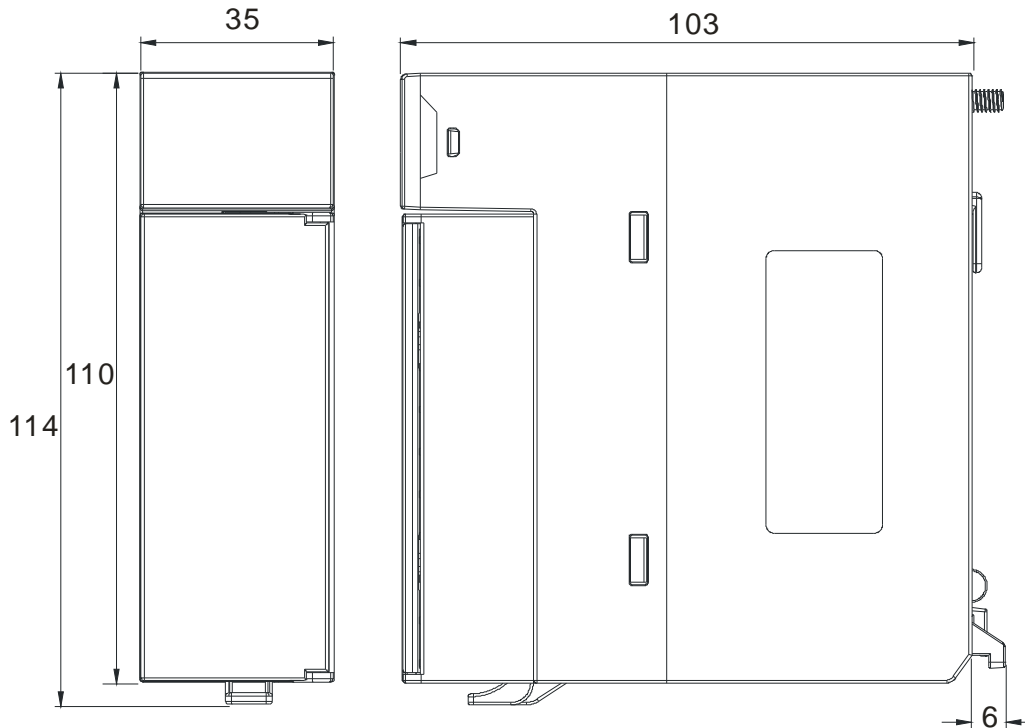

Unit: mm

3.6.4 Arrangement of Input/Output Terminals

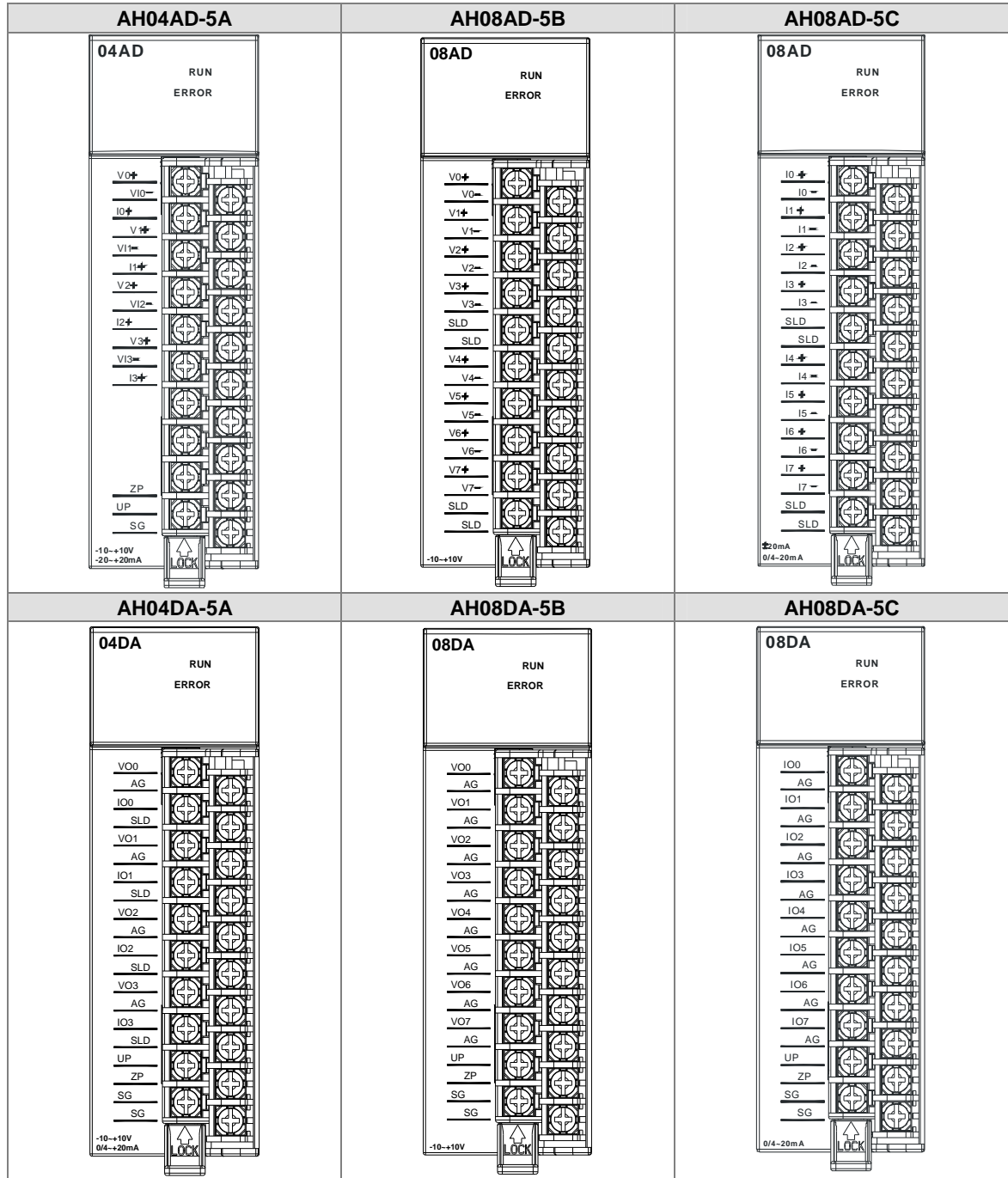

3

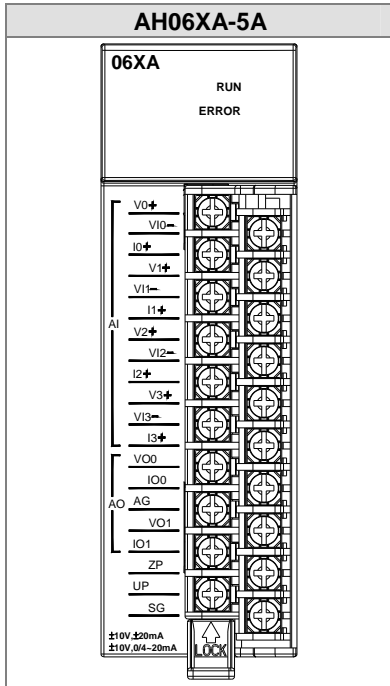

3.7 Specifications for Temperature Measurement Modules

3.7.1 General Specifications

- AH04PT-5A

Electrical specifications

Number of analog inputs	4
Applicable sensor	Three-wire configuration: Pt100/Ni100/Pt1000/Ni1000 sensor, and 0~300 Ω input impedance Two-wire/Four-wire configuration: Pt100/Ni100/Pt1000/Ni1000 sensor, and 0~300 Ω input impedance Pt100: DIN 43760-1980 JIS C1604-1989; 100 Ω 3850 PPM/°C Pt1000: DIN EN60751; 1 kΩ 3850 PPM/°C Ni100/Ni1000: DIN 43760
Supply voltage	24 V DC (20.4 V DC~28.8 V DC) (-15%~+20%)
Connector type	Removable terminal block
Overall accuracy	25°C/77°F: The error is ±0.5% of the input within the range. -20~60°C/-4~140°F: The error is ±1% of the input within the range.
Conversion time	Two-wire/Four-wire configuration: 150 ms/channel Three-wire configuration: 300 ms/channel
Isolation	An analog circuit is isolated from a digital circuit by a digital integrated circuit/an optocoupler, and the analog channels are isolated from one another by optocouplers. Isolation between a digital circuit and a ground: 500 V DC Isolation between an analog circuit and a ground: 500 V DC Isolation between an analog circuit and a digital circuit: 500 V DC Isolation between the 24 V DC and a ground: 500 V DC

Functional specifications

Analog-to-digital conversion	Centigrade (°C)	Fahrenheit (°F)	Input impedance
Rated input range	Pt100: -180°C~800°C Ni100: -80°C~170°C Pt1000: -180°C~800°C Ni1000: -80°C~170°C	Pt100: -292°F~1,472°F Ni100: -112°F~338°F Pt1000: -292°F~1,472°F Ni1000: -112°F~338°F	0~300 Ω
Average function	Range: 1~100		
Self-diagnosis	Disconnection detection		

● AH08PTG-5A

Electrical specifications

Number of analog inputs	8
Applicable sensor	Three-wire configuration: Pt100/Ni100/Pt1000/Ni1000 sensor, and 0~300 Ω input impedance Two-wire/Four-wire configuration: Pt100/Ni100/Pt1000/Ni1000 sensor, and 0~300 Ω input impedance Pt100: DIN 43760-1980 JIS C1604-1989; 100 Ω 3850 PPM/°C Pt1000: DIN EN60751; 1 kΩ 3850 PPM/°C Ni100/Ni1000: DIN 43760
Supply voltage	24 V DC (20.4 V DC~28.8 V DC) (-15%~+20%)
Connector type	Removable terminal block
Overall accuracy	The error is ±1°C of a Pt100/Pt1000/Ni100/Ni1000 sensor's temperature. The error is ±0.1% of a resistance in the range of 0 Ω to 300 Ω.
Conversion time	<ul style="list-style-type: none"> Quick mode: Four-wire/Two-wire configuration: 20 ms/channel Three-wire configuration: 200 ms/channel General mode: A conversion time will be gotten after the conversion time of the two channels in a group is added up. Four-wire/Two-wire configuration: 200 ms/channel Three-wire configuration: 400 ms/channel
Isolation	An analog circuit is isolated from a digital circuit by a digital integrated circuit, and the analog channels are isolated from one another by optocouplers. Isolation between a digital circuit and a ground: 500 V DC Isolation between an analog circuit and a ground: 500 V DC Isolation between an analog circuit and a digital circuit: 500 V DC Isolation between two group circuits: 500 V DC Isolation between the 24 V DC and a ground: 500 V DC

3

Functional specifications

Analog-to-digital conversion	Centigrade (°C)	Fahrenheit (°F)	Input impedance
Rated input range	Pt100: -180°C~800°C Ni100: -80°C~170°C Pt1000: -180°C~800°C Ni1000: -80°C~170°C	Pt100: -292°F~1,472°F Ni100: -112°F~338°F Pt1000: -292°F~1,472°F Ni1000: -112°F~338°F	0~300 Ω
Average function	Range: 1~100		
Self-diagnosis	Disconnection detection		

● AH04TC-5A/AH08TC-5A

Electrical specifications

Module name	AH04TC-5A	AH08TC-5A
Number of analog inputs	4	8

3

Module name	AH04TC-5A	AH08TC-5A
Applicable sensor	Type J, type K, type R, type S, type T, type E, and type N thermocouples ±150 mV voltage inputs	
Supply voltage	24 V DC (20.4 V DC~28.8 V DC) (-15%~+20%)	
Connector type	Removable terminal block	
Overall accuracy	25°C/77°F: The error is ±0.5% of the input within the range -20~60°C/-4~140°F: The error is ±1% of the input within the range	
Conversion time	200 ms/channel	
Isolation	An analog circuit is isolated from a digital circuit by a digital integrated circuit/an optocoupler, and the analog channels are isolated from one another by optocouplers. Isolation between a digital circuit and a ground: 500 V DC Isolation between an analog circuit and a ground: 500 V DC Isolation between an analog circuit and a digital circuit: 500 V DC Isolation between the 24 V DC and a ground: 500 V DC Isolation between analog channels: 120 V AC	

Functional specifications

Analog-to-digital conversion	Centigrade (°C)	Fahrenheit (°F)	Voltage input
Rated input range	Type J: -100°C~1,150°C Type K: -100°C~1,350°C Type R: 0°C~1,750°C Type S: 0°C~1,750°C Type T: -150°C~390°C Type E: -150°C~980°C Type N: -150°C~1,280°C	Type J: -148°F~2,102°F Type K: -148°F~2,462°F Type R: 32°F~3,182°F Type S: 32°F~3,182°F Type T: -238°F~734°F Type E: -238°F~1,796°F Type N: -238°F~2,336°F	±150 mV
Average function	Range: 1~100		
Self-diagnosis	Disconnection detection		

3.7.2 Profiles

● AH04PT-5A/AH04TC-5A/AH08TC-5A

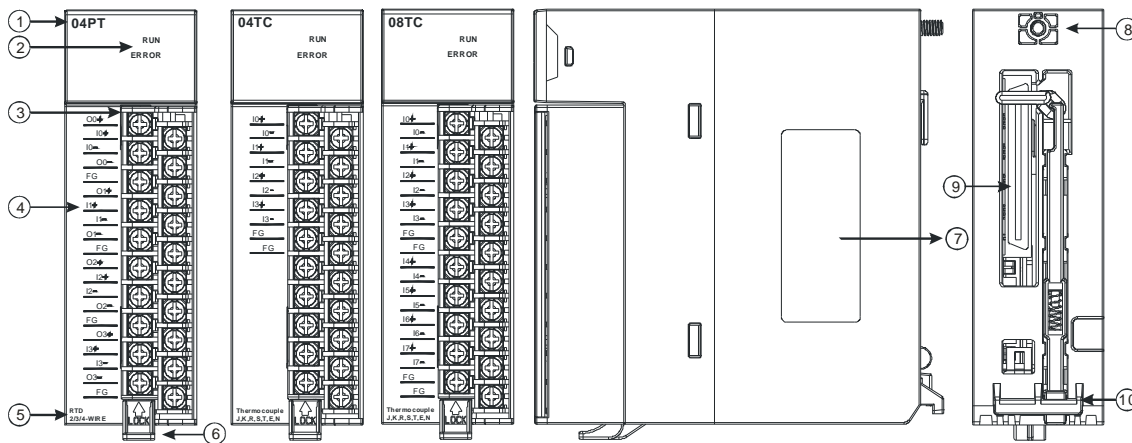

Number	Name	Description
1	Model name	Model name of the module
2	RUN LED indicator	Operating status of the module ON: The module is running. OFF: The module stops running.
	ERROR LED indicator	Error status of the module ON: A serious error occurs in the module. OFF: The module is normal. Blinking: A slight error occurs in the module.

Number	Name	Description
3	Removable terminal block	The inputs are connected to a sensor.
4	Arrangement of the input terminals	Arrangement of the terminals
5	Description of the inputs	Simple specifications for the module
6	Clip	Removing the terminal block
7	Label	Nameplate
8	Set screw	Fixing the module
9	Connector	Connecting the module and a backplane
10	Projection	Fixing the module

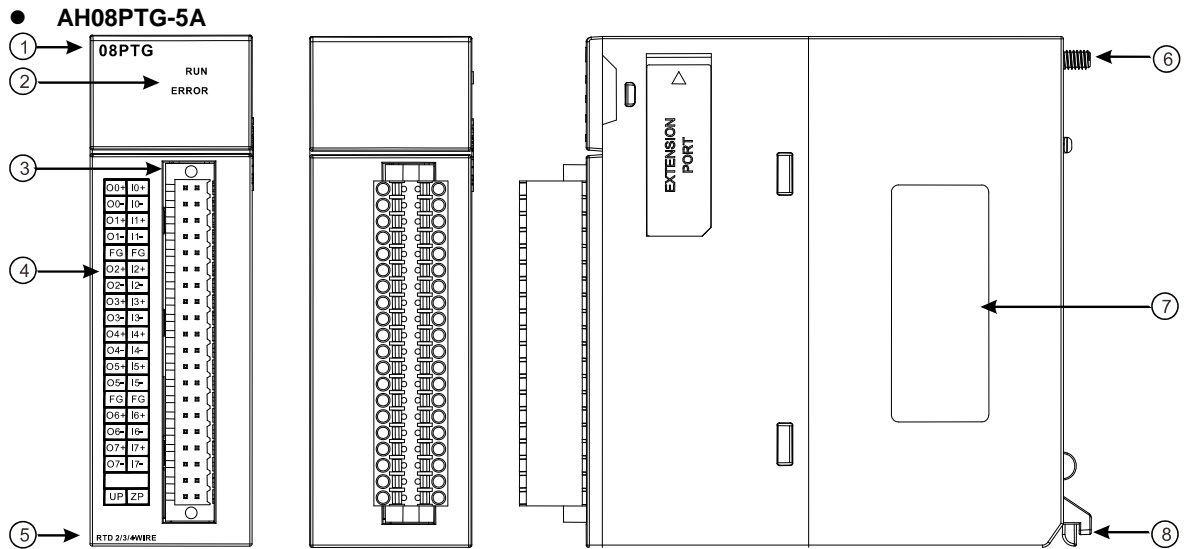

3

Number	Name	Description
1	Model name	Model name of the module
2	RUN LED indicator	Operating status of the module ON: The module is running. OFF: The module stops running.
	ERROR LED indicator	Error status of the module ON: A serious error occurs in the module. OFF: The module is normal. Blinking: A slight error occurs in the module.
3	Removable terminal block	The inputs are connected to a sensor.
4	Arrangement of the input terminals	Arrangement of the terminals
5	Description of the inputs	Simple specifications for the module
6	Set screw	Fixing the module
7	Label	Nameplate
8	Projection	Fixing the module

3.7.3 Dimensions

- AH04PT-5A/AH04TC-5A/AH08TC-5A

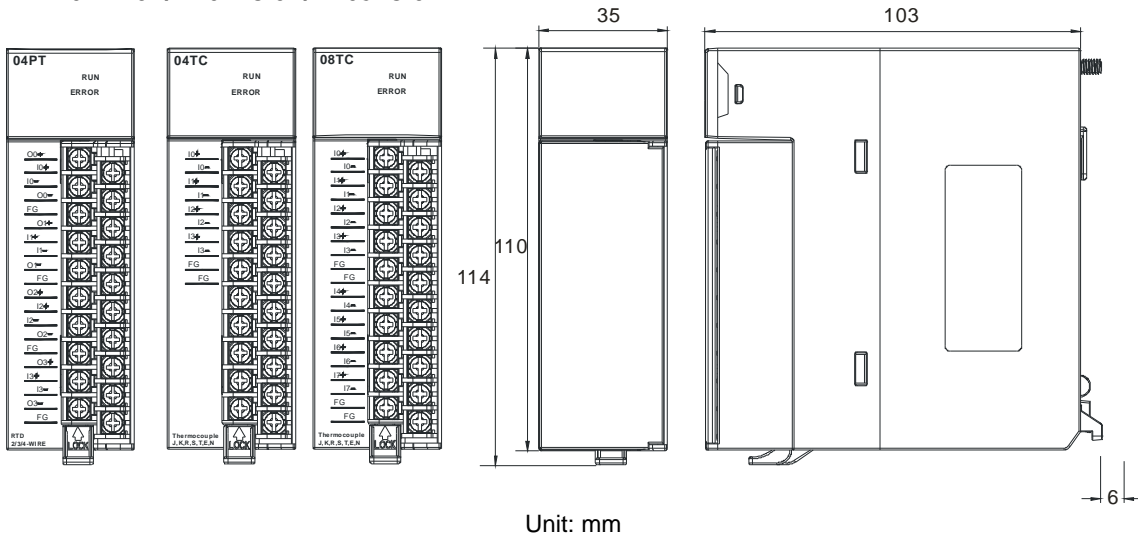

- AH08PTG-5A

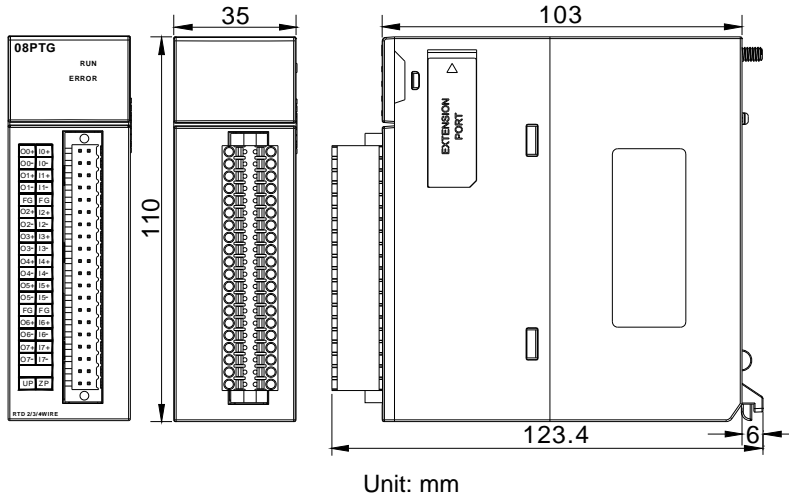

3

3.7.4 Arrangement of Input/Output Terminals

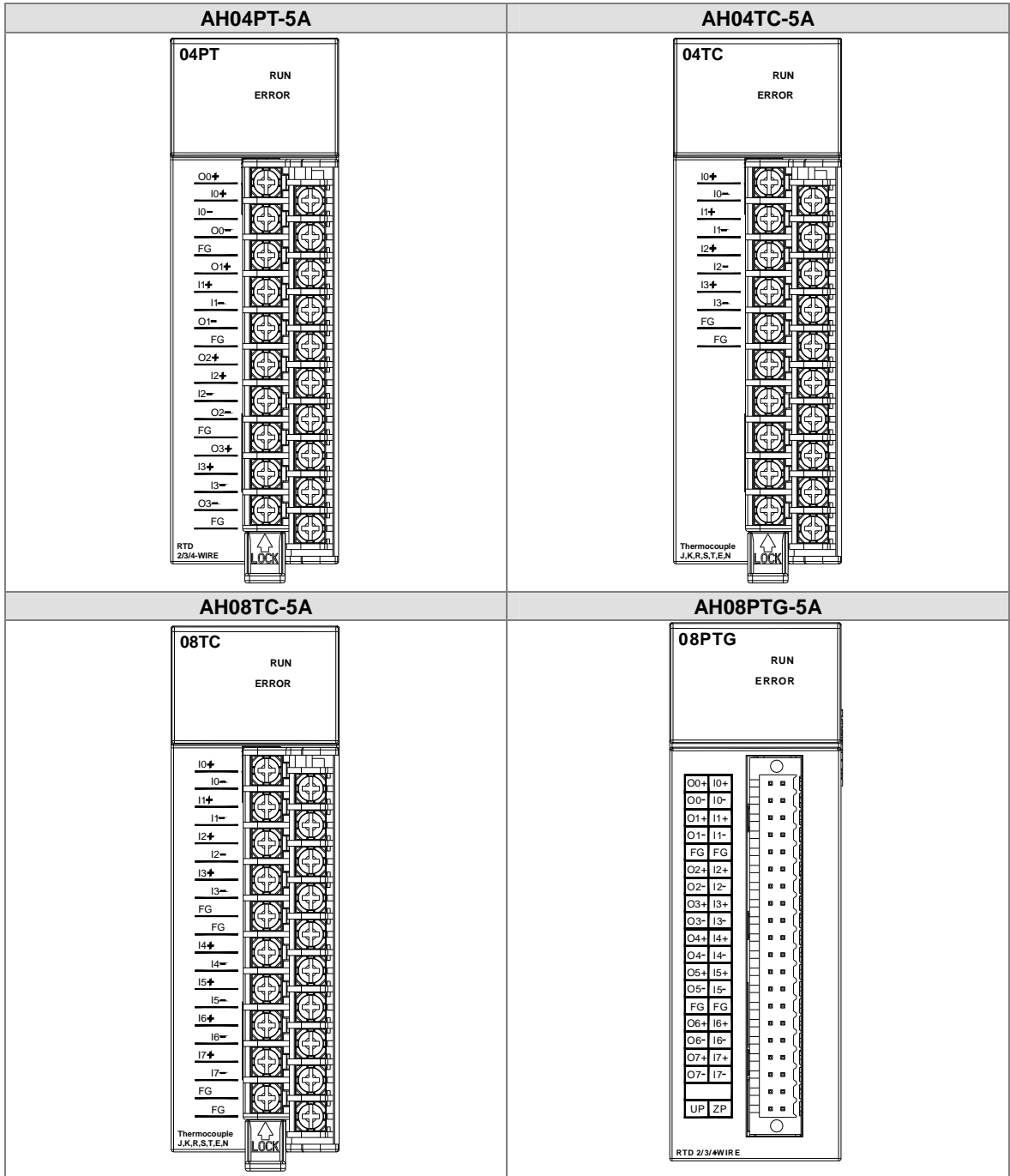

3

3.8 Specifications for Network Modules

3.8.1 General Specifications

- AH10SCM-5A
RS-485/RS-422 communication interface

Item	Specifications
Connector type	European-style terminal block
Transmission speed	1,200, 2,400, 4,800, 9,600, 19,200, 38,400, 57,600, 76,800, 115,200, 230,400, and 460,800 bps
Communication format	Stop bit: 1 stop bit or 2 stop bits Parity bit: none, an odd parity bit, or an even parity bit Data bit: 7 data bits or 8 data bits
Communication protocol	Modbus ASCII/RTU UD Link BACnet MS/TP slave stations

Electrical specifications

Item	Specifications
Supply voltage	5 V DC
Electric energy consumption	1.5 W
Insulation voltage	2,500 V DC
Weight	Approximately 131 g

- AH10EN-5A
Network interface

Item	Specifications
Connector type	RJ-45 with auto-MDI/MDIX
Transmission interface	802.3 and 802.3u
Transmission cable	Category 5e cable The maximum length is 100 meters.
Transmission speed	10/100 Mbps auto-detection
Communication protocol	ICMP, IP, TCP, UDP, DHCP, NTP, Modbus TCP, SNMP, and SMTP

Electrical specifications

Item	Specifications
Supply voltage	5 V DC
Electric energy consumption	1.5 W
Insulation voltage	2,500 V DC
Weight	Approximately 139 g

- AH10DNET-5A
AH500 series CPU modules which are supported

Item	Specifications
Model name	AH500 series PLCs

DeviceNet interface

Item	Specifications
Transmission method	CAN
Electrical isolation	500 V DC
Connector	Removable connector (5.08 mm)

Item	Specifications
Communication cable	The Delta standard cables TAP-CB01 and TAP-CB02 are recommended. The communication cable should be away from the power cable and the shielded cable should be connected to the ground.
Voltage	DeviceNet network provides 11~25 V direct current. e.g. 28 mA (Typical value), 125 mA impulse current (24 V DC).

DeviceNet Communication

Item	Specifications
Message type	Master mode: Supporting explicit messages, and all kinds of I/O connections with the slave such as I/O polled connections, bit-strobed connections, state changing connections, and cyclic connections Slave mode: Supporting explicit messages and a group 2 only server
Transmission speed	Standard: 125 kbps, 250 kbps and 500 kbps Extension: 10 kbps, 20 kbps, 50 kbps, 125 kbps, 250 kbps, 500 kbps, 800 kbps and 1 Mbps



- **AH10PFBM-5A**
AH500 series CPU module supported

Item	Specifications
Model name	AH500 series PLCs

PROFIBUS-DP interface

Item	Specifications
Interface	DB9 connector
Transmission method	High-speed RS-485
Transmission cable	Two-wire twisted shielded cable
Electrical isolation	500 V DC

PROFIBUS-DP communication

Item	Specifications
Message type	Cyclic data exchange
Module name	AH10PFBM-5A
Product ID	0B49
Serial transmission speed supported (auto-detection)	9.6 kbps; 19.2 kbps; 31.25 kbps; 45.45 kbps; 93.75 kbps; 187.5 kbps; 500 kbps; 1.5 Mbps; 3 Mbps; 6 Mbps; 12 Mbps

Electrical specification

Item	Specifications
Power supply voltage	5 V DC
Insulation voltage	500 V DC
Power consumption	2 W
Weight	190 g

- **AH10PFBS-5A**
PROFIBUS-DP port

Interface	DB9 connector
Transmission method	High-speed RS-485
Transmission cable	Shielded twisted pair cable
Electrical isolation	500 V DC

Communication

Message type	Cyclic data exchange
Module name	AH10PFBS-5A
GSD file	DELA0AFE.GSD
Product ID	0AFE
Serial transmission speed supported (auto-detection)	9.6 kbps; 19.2 kbps; 45.45 (31.25) kbps; 93.75 kbps; 187.5 kbps; 500 kbps; 1.5 Mbps; 3 Mbps; 6 Mbps; 12 Mbps

Electrical specification

Power supply voltage	5 V DC
Insulation voltage	500 V DC
Power consumption	2 W
Weight	115 g

3

- **AH10COPM-5A**
CANopen interface

Item	Specifications
Transmission method	CAN
Electrical isolation	500 V DC
Connector	Removable connector (5.08 mm)
Communication cable	It is suggested that users should use the Delta standard cables TAP-CB01 and TAP-CB02. The communication cable used should be away from the power cable used, and the shielded cables used should be connected to the ground.

CANopen communication

Item	Specifications
Message type	PDO, SDO, SYNC, EMCY, NMT
Transmission speed	10 kbps, 20 kbps, 50 kbps, 125 kbps, 250 kbps, 500 kbps, 800 kbps, 1 Mbps

Electrical specifications

Item	Specifications
Supply voltage	A CPU module supplies 24 V DC (-15%~20%) power through an internal bus.
Electric energy consumption	1.7 W
Insulation voltage	500 V

3.8.2 Profiles

● AH10SCM-5A

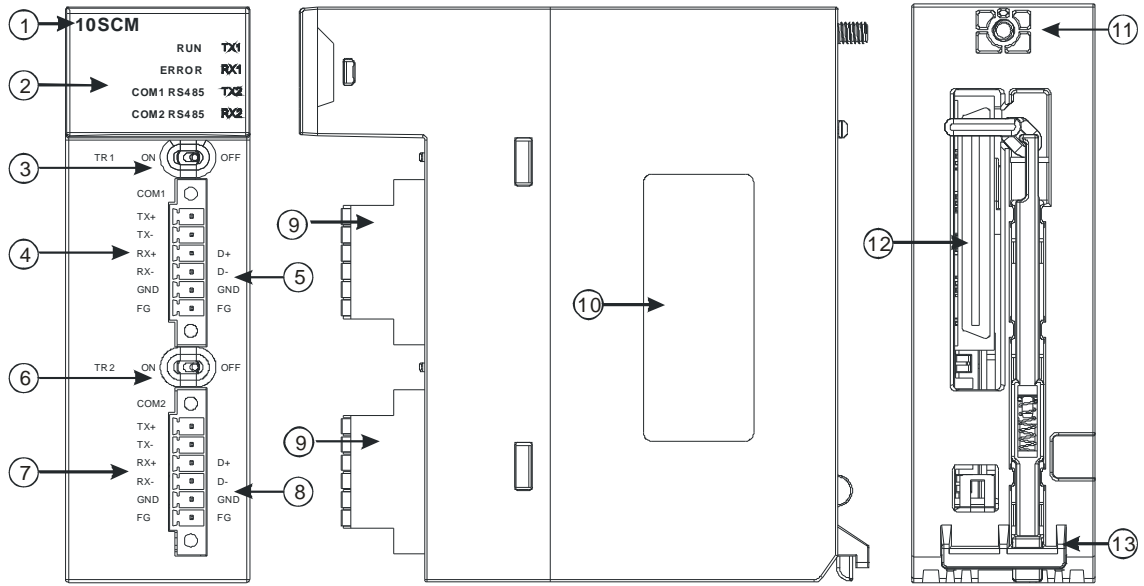

3

Number	Name	Description
1	Model name	Model name of the module
2	RUN LED indicator (green)	Operating status of the module ON: The module is running. OFF: The module stops running.
	ERROR LED indicator (red)	Error status of the module ON: There is a hardware error. OFF: The module is normal. Blinking: 1. The setting of the module is incorrect, or there is a communication error. 2. Restoring the module to the default factory value
	COM1 (RS-485) LED indicator (green)	ON: RS-485 mode OFF: RS-422 mode
	COM2 (RS-485) LED indicator (green)	ON: RS-485 mode OFF: RS-422 mode
	TX1/TX2 LED indicator (orange)	Blinking: The data is being transmitted through the RS-485/RS422 port. OFF: The data is not being transmitted through the RS-485/RS422 port.
3	Switch of terminal resistor 1	Switching terminal resistor 1 ON/OFF
	Switch of terminal resistor 2	Switching terminal resistor 2 ON/OFF
4	Terminals	Terminals for COM1 (RS-422)
5	Terminals	Terminals for COM1 (RS-485)
6	Terminals	Terminals for COM2 (RS-422)
7	Terminals	Terminals for COM2 (RS-485)
8	European-style terminal block	Terminals for wiring
9	Label	Nameplate
10	Set screw	Fixing the module
11	Connector	Connecting the module and a backplane
12	Projection	Fixing the module

● AH10EN-5A

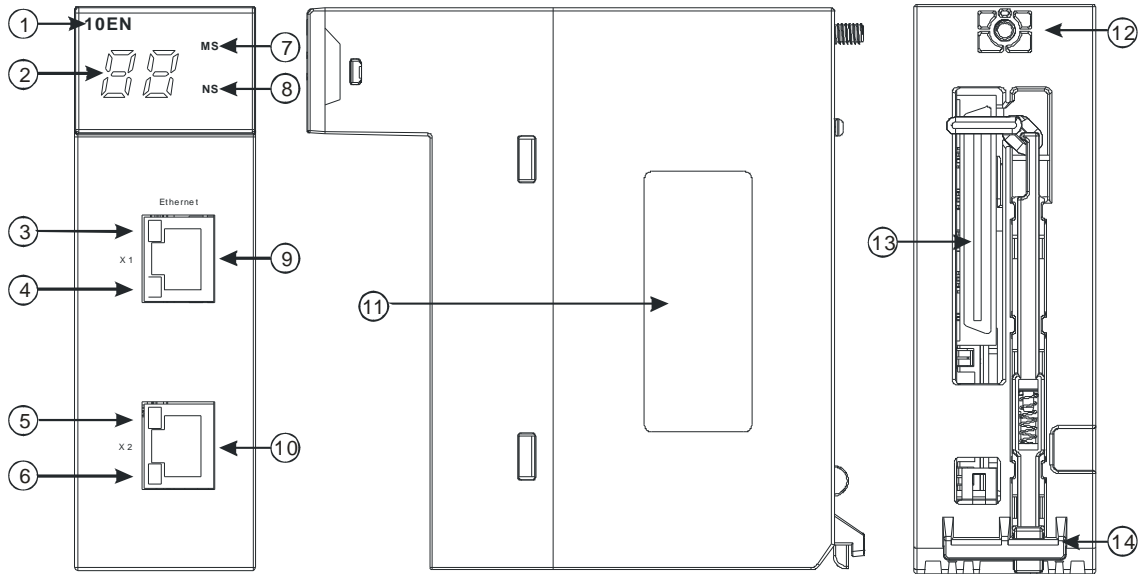

Number	Name	Description
1	Model name	Model name of the module
2	Seven-segment display	Display
3	LINK LED indicator	LINK LED indicator for RJ45 port 1
4	ACK LED indicator	ACK LED indicator for RJ45 port 1
5	LINK LED indicator	LINK LED indicator for RJ45 port 2
6	ACK LED indicator	ACK LED indicator for RJ45 port 2
7	NS LED indicator	LED indicator
8	MS LED indicator	LED indicator
9	RJ45 port 1	RJ45 port 1
10	RJ45 port 2	RJ45 port 2
11	Label	Nameplate
12	Set screw	Fixing the module
13	Connector	Connecting the module and a backplane
14	Projection	Fixing the module

● AH10DNET-5A

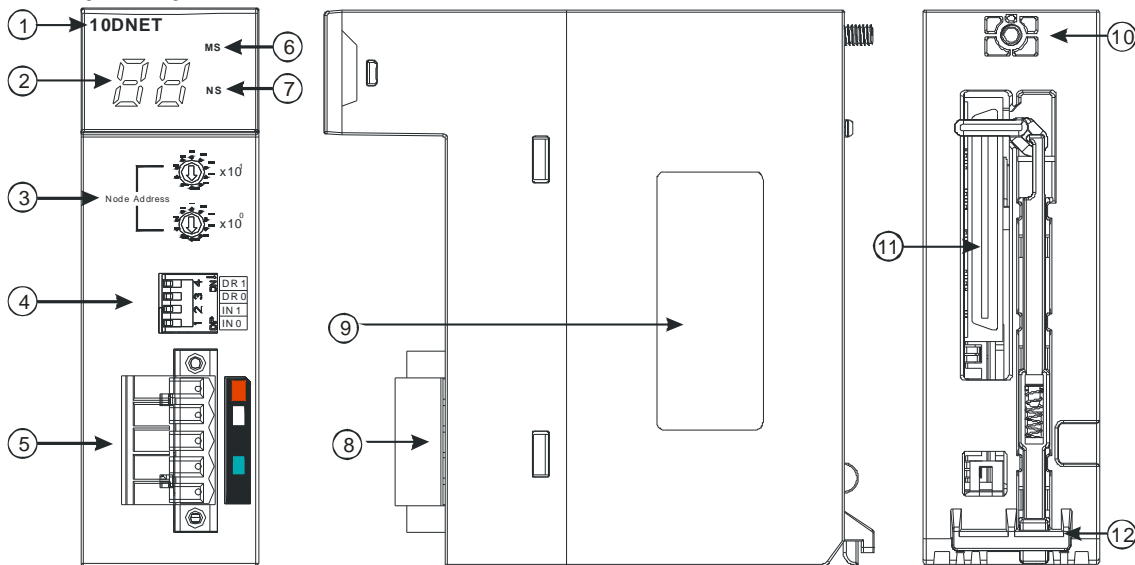

Number	Name	Description
1	Model name	Model name of the module
2	Seven-segment display	Display
3	Address knobs	Setting the address
4	Function switch	Setting the functions
5	DeviceNet connector	DeviceNet is used to interconnect control devices for data exchange.
6	MS LED indicator	Indicating the status of the module
7	NS LED indicator	Indicating the status of the network
8	Removable terminal block	Terminals for wiring
9	Label	Nameplate
10	Set screw	Fixing the module
11	Connector	Connecting the module and a backplane.
12	Projection	Fixing the module

1. Address knobs

It is used to set the node address of AH10DNET-5A on a DeviceNet network. (Node addresses range from 0 to 63.)

Setting	Description
0...63	Available nodes on a DeviceNet network
64...99	Unavailable nodes on a DeviceNet network

Example: If users want to set the communication address of AH10DNET-5A to 26, they can turn the knob corresponding to $x10^1$ to 2, and turn the knob corresponding to $x10^0$ to 6.

Points for attention:

- When the power supply is cut off, the node address is set. After the setting of the node address is complete, AH10DNET-5A can be supplied with power.
- If AH10DNET-5A is running, changing the node address is unavailable.
- Please use a slotted screwdriver to turn the knobs with care, and do not scrape them.

3

2. Function switch

The function switch provides the following functions:

- Setting the working mode (IN 0)
- Setting the transmission speed of a DeviceNet network (DR 0~DR 1)

DR 1	DR 0	Transmission speed
OFF	OFF	125 kbps
OFF	ON	250 kbps
ON	OFF	500 kbps
ON	ON	Entering the extendable serial transmission speed mode
IN 1 Reserved		
IN 0	ON	If the slave is disconnected, the previous I/O data is retained.
	OFF	If the slave is disconnected, the previous I/O data is cleared.

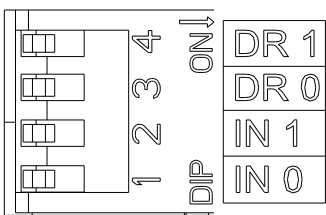

Points for attention:

- When the power supply is cut off, the functions are set. After the setting of the functions is complete, AH10DNET-5A can be supplied with power.
- If AH10DNET-5A is running, changing the functions is unavailable.
- Please use a slotted screwdriver to adjust the DIP switch with care, and do not scrape them.

3. DeviceNet connector

Pin	Signal	Color	Description
5	V+	Red	24 V DC
4	CAN_H	White	Signal (positive pole)
3	SHIELD	-	It is connected to a shielded cable.
2	CAN_L	Blue	Signal (negative pole)
1	V-	Black	0 V DC



● AH10PFBM-5A

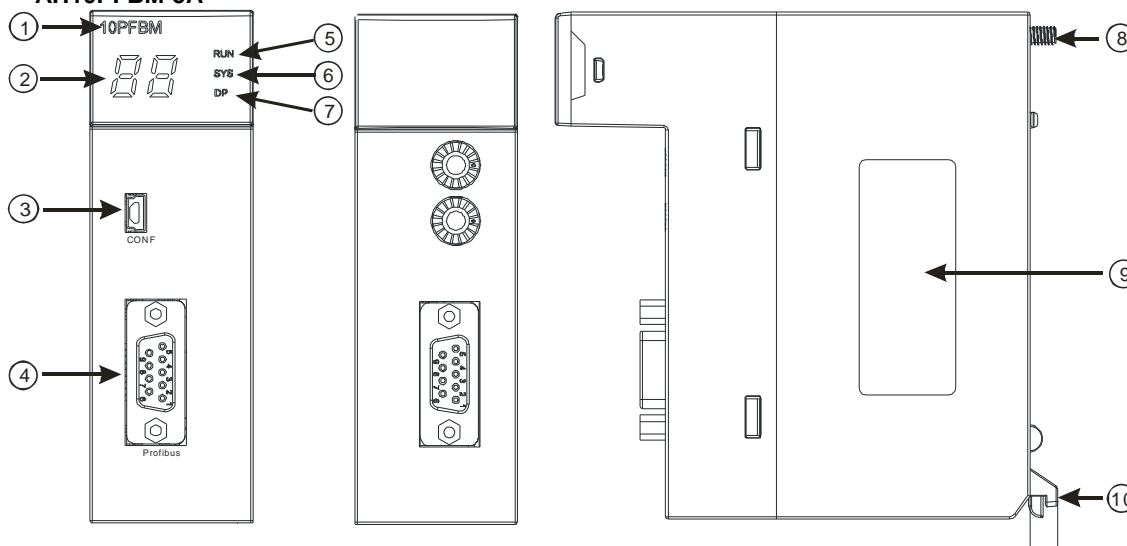

Number	Name	Description
1	Model name	Model name of the module
2	Seven-segment display	Display
3	CONF interface	The interface where the hardware configuration is downloaded

3

Number	Name	Description
4	PROFIBUS-DP interface	PROFIBUS-DP connection
5	RUN LED indicator	LED indicator indicator
6	SYS LED indicator	LED indicator indicator
7	DP LED indicator	LED indicator indicator
8	Set screw	Fixing the module
9	Label	Nameplate
10	Projection	Fixing the module

1. PROFIBUS-DP port

A PROFIBUS-DP port is used to connect a module to a PROFIBUS-DP network. Users can wire AH10PFBM-5A by using the connector attached to AH10PFBM-5A.

Pin	PIN name	Description
1	--	N/C
2	--	N/C
3	RxD/TxD-P	Receiving/Sending data (P (B))
4	--	N/C
5	DGND	Data reference potential (C)
6	VP	Supplying positive voltage
7	--	N/C
8	RxD/TxD-N	Receiving/Sending data (N (A))
9	--	N/C

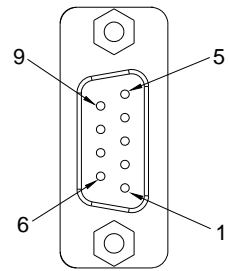

3

● **AH10PFBS-5A**

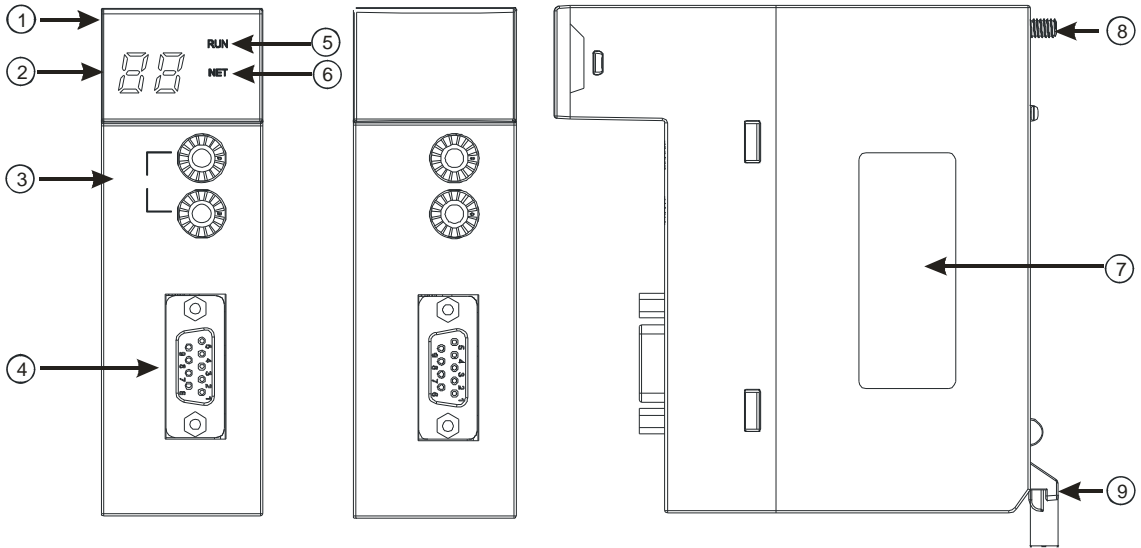

Number	Name	Description
1	Model name	Model name of the module
2	Seven-segment display	Display
3	Address knobs	Setting the address
4	PROFIBUS-DP interface	PROFIBUS-DP connection
5	RUN LED indicator	Operating status of the module
6	NET LED indicator	Status of a network
7	Label	Nameplate
8	Set screw	Fixing the module
9	Projection	Fixing the module

1. Setting a PROFIBUS node address

The address knobs of AH10PFBS-5A are used for setting the node address of AH10PFBS-5A on a PROFIBUS-DP network. There are two address knobs. They are a knob corresponding to $x16^0$, and a knob corresponding to $x16^1$. The range for one address knob is 0~F.

The range for setting the node address is described below.

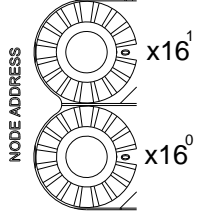
Address	Definition	
H'1~H'7D	Valid PROFIBUS address	
H'0 or H'7E~H'FF	Invalid PROFIBUS address	

Example: If users need to set the node address of AH10PFBS-5A to 26 (decimal value), they have to turn the knob corresponding to $x16^1$ to "1", and the knob corresponding to $x16^0$ to "A".

$$26 \text{ (decimal value)} = 1A \text{ (hexadecimal value)} = 1 \times 16^1 + A \times 16^0.$$

Points for attention:

- If users set the node address of AH10PFBS-5A when AH10PFBS-5A is not supplied with power, they have to power AH10PFBS-5A after the node address of AH10PFBS-5A is set.
- If users change the node address of AH10PFBS-5A when AH10PFBS-5A is powered, the change will not take effect immediately after the node address of AH10PFBS-5A is changed, and it will take effect after the users cut off the power supplied to AH10PFBS-5A and then power AH10PFBS-5A again.
- To prevent the address knobs on AH10PFBS-5A from being scratched, please carefully use a slotted screwdriver to rotate the address knobs on AH10PFBS-5A.

2. Definitions of the pins in the PROFIBUS-DP port

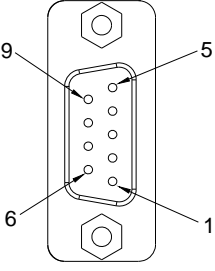
Pin	PIN name	Description	
1	--	N/C	
2	--	N/C	
3	RxD/TxD-P	Sending/receiving data (P (B))	
4	--	N/C	
5	DGND	Data reference potential (C)	
6	VP	Supplying positive voltage	
7	--	N/C	
8	RxD/TxD-N	Sending/receiving data (N (A))	
9	--	N/C	

● AH10COPM-5A

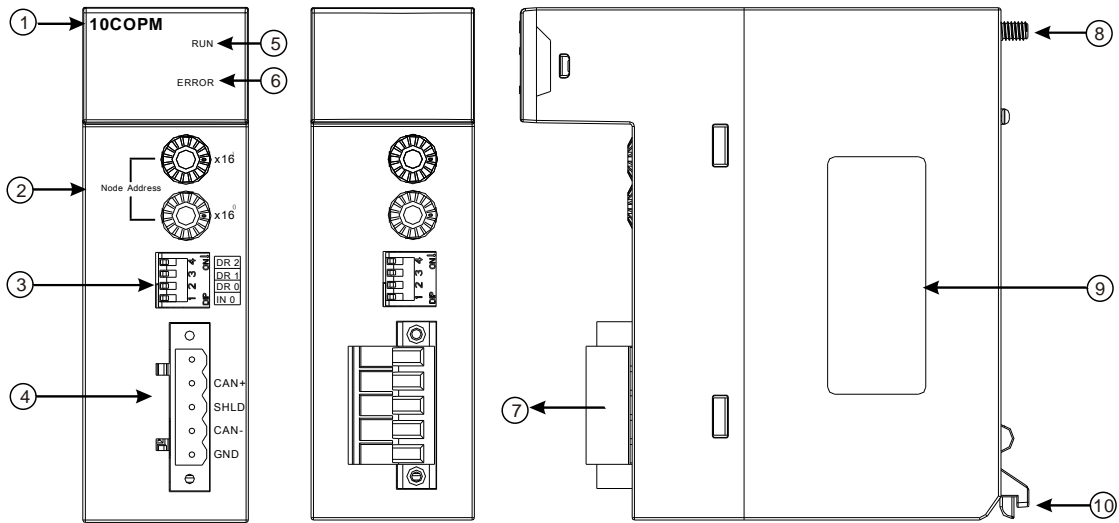

Number	Name	Description
1	Model name	Model name of the module
2	Address knobs	For setting an address
3	Function switch	For setting a function
4	CANOpen connector	For a CANOpen connection
5	RUN LED indicator	Operating status of the module
6	ERROR LED indicator	Error status of the module
7	Removable terminal block	Terminals
8	Set screw	Fixing the module
9	Label	Nameplate
10	Projection	Fixing the module

1. CANOpen communication connector

A CANOpen connector is connected to a CANOpen network. Please wire AH10COPM-5A by using the connector attached to AH10COPM-5A.

Pin	Signal	Description
5	-	Reserved
4	CAN+	CAN_H
3	SHLD	Shielded cable
2	CAN-	CAN_L
1	GND	0 V DC

2. Address knobs

The address knobs on AH10COPM-5A are used to set the node address of AH10COPM-5A on a CANOpen network. Setting range: 1~7F (0 and 80~FF can not be used.)

Setting	Description
1~7F	Valid CANOpen node address
0, 80~FF	Invalid CANOpen node address

Example: If the station address of AH10COPM-5A is 16#26, users have to turn the knob corresponding to $x16^1$ to position 2, and turn the knob corresponding to $x16^0$ to position 6.

Points for attention:

- After the station address of AH10COPM-5A is changed, users have to power AH10COPM-5A

again, otherwise the change will not take effect.

- To prevent the address knobs on AH10COPM-5A from being scratched, please carefully use a slotted screwdriver to rotate the address knobs on AH10COPM-5A.

3. Function switch

The function switch on AH10COPM-5A is used to set the communication speed at which AH10COPM-5A is connected to a CANopen network. There is a limit on the maximum communication distance to which a communication speed corresponds.

DR 2	DR 1	DR 0	Communication speed	Maximum communication distance
OFF	OFF	OFF	10 kbps	5000 m
OFF	OFF	ON	20 kbps	2500 m
OFF	ON	OFF	50 kbps	1000 m
OFF	ON	ON	125 kbps	500 m
ON	OFF	OFF	250 kbps	250 m
ON	OFF	ON	500 kbps	100 m
ON	ON	OFF	800 kbps	50 m
ON	ON	ON	1 Mbps	25 m
IN 0				Reserved

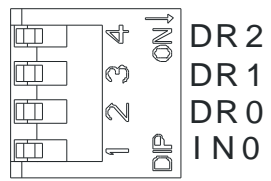

Points for attention:

- After users change the communication speed at which AH10COPM-5A is connected to a CANopen network, they have to power AH10COPM-5A again, otherwise the change will not take effect.
- To prevent the DIP switch on AH10COPM-5A from being scratched, please carefully use a slotted screwdriver to rotate the DIP switch on AH10COPM-5A.

3.8.3 Dimensions

● AH10SCM-5A

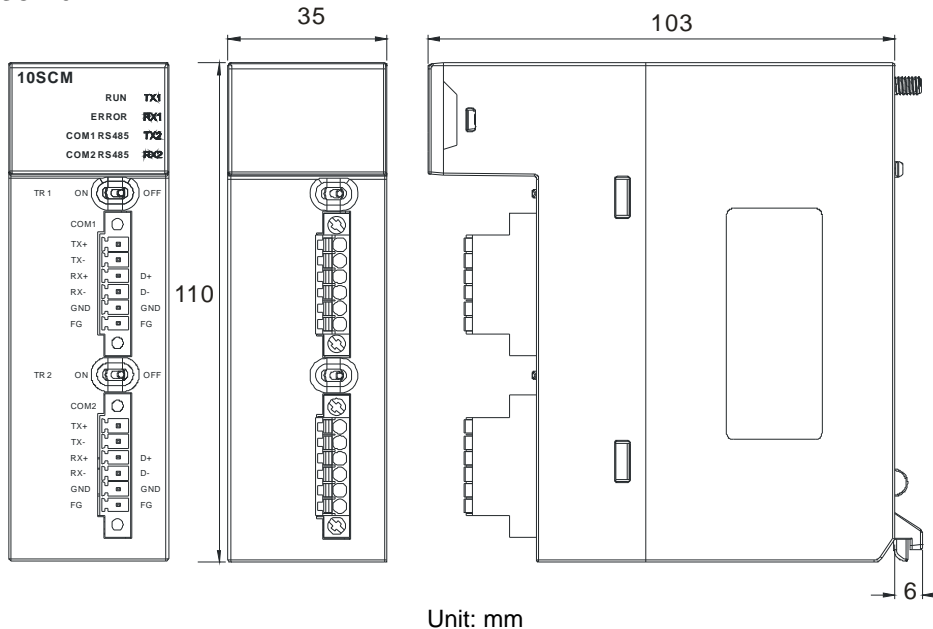

3

● AH10EN-5A

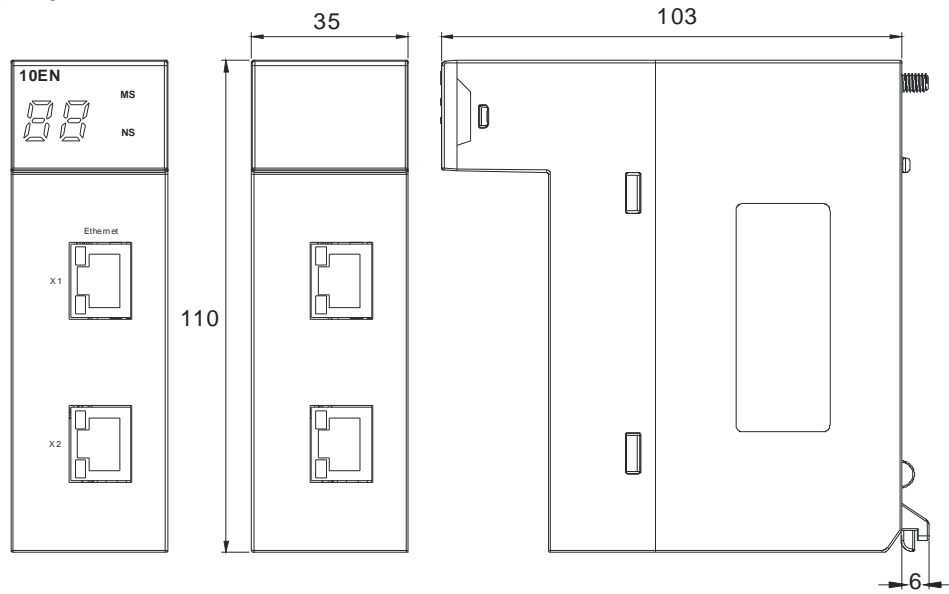

Unit: mm

● AH10DNET-5A

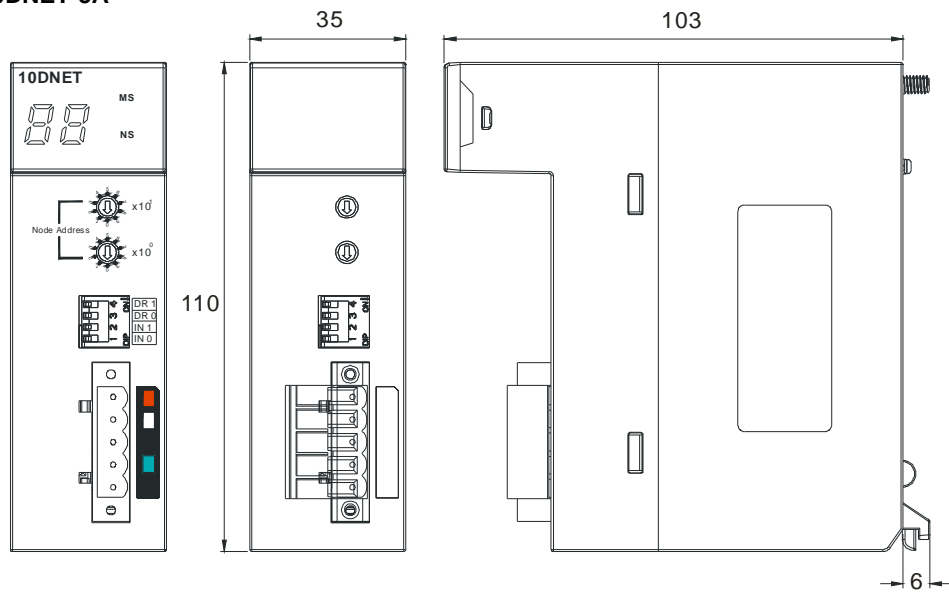

Unit: mm

3

3

● AH10PFBM-5A

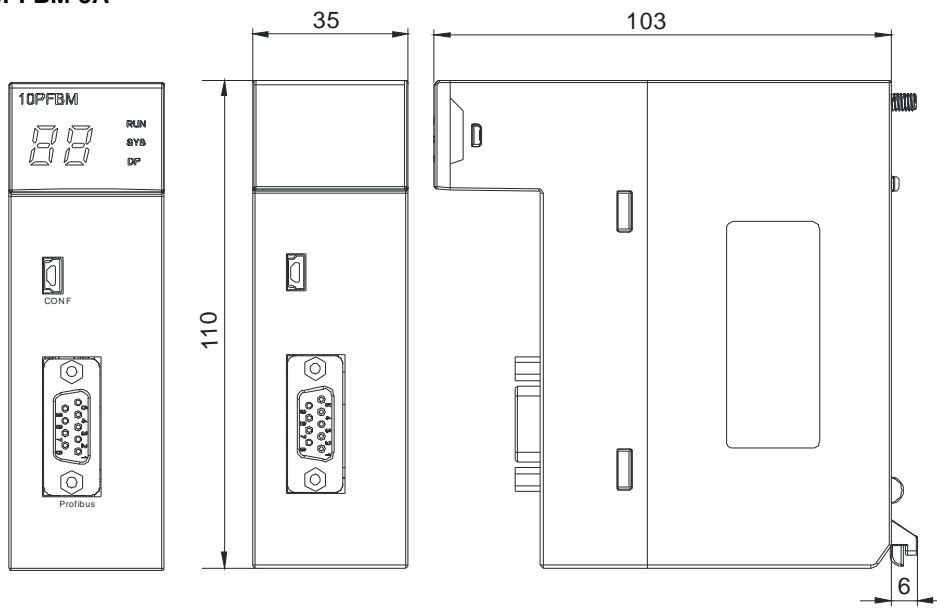

Unit: mm

● AH10PFBS-5A

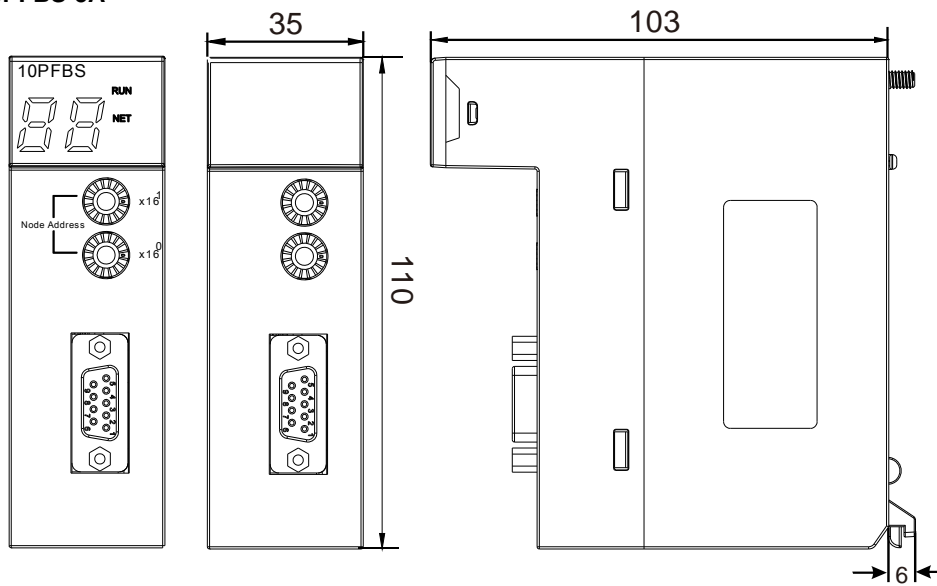

Unit: mm

● AH10COPM-5A

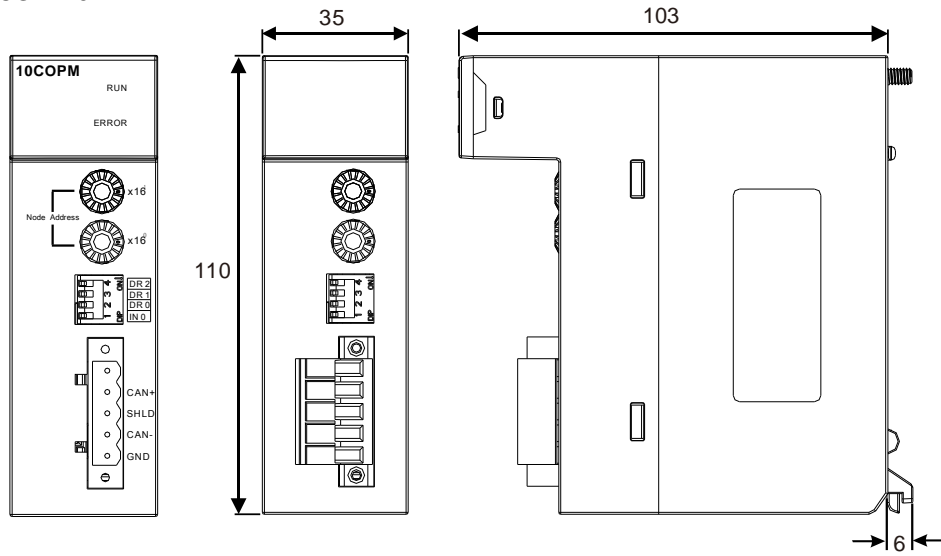

Unit: mm

3

3.8.4 Arrangement of Input/Output Terminals

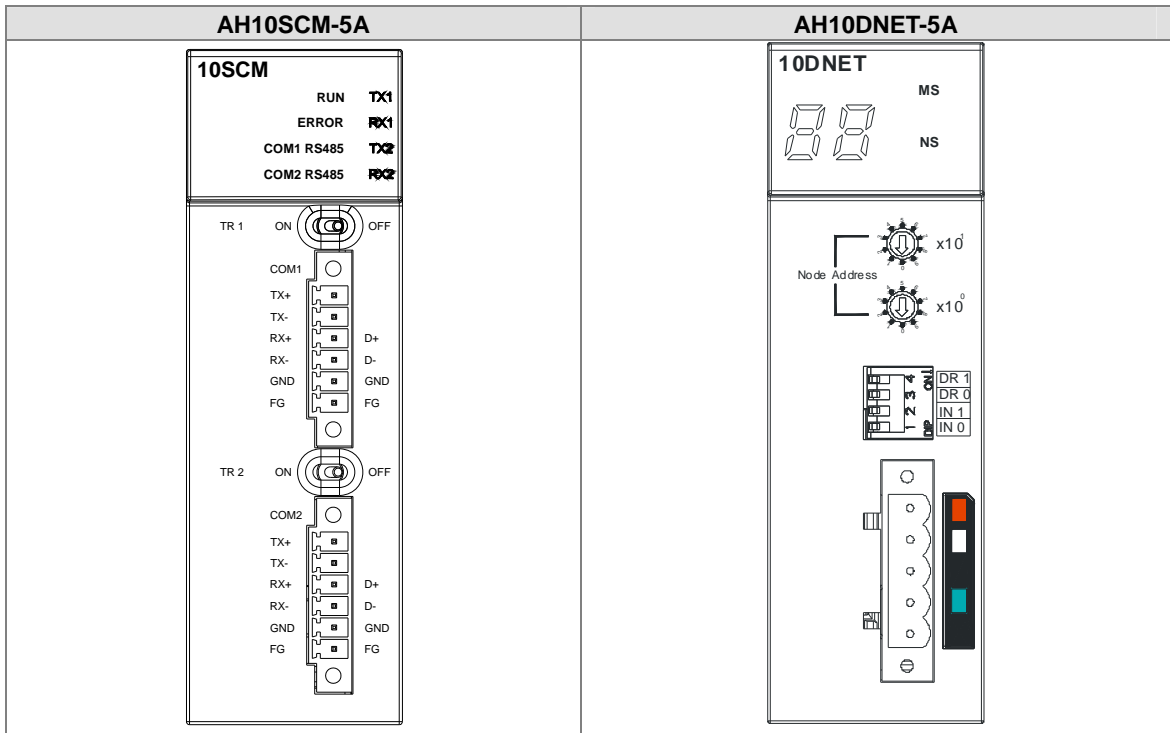

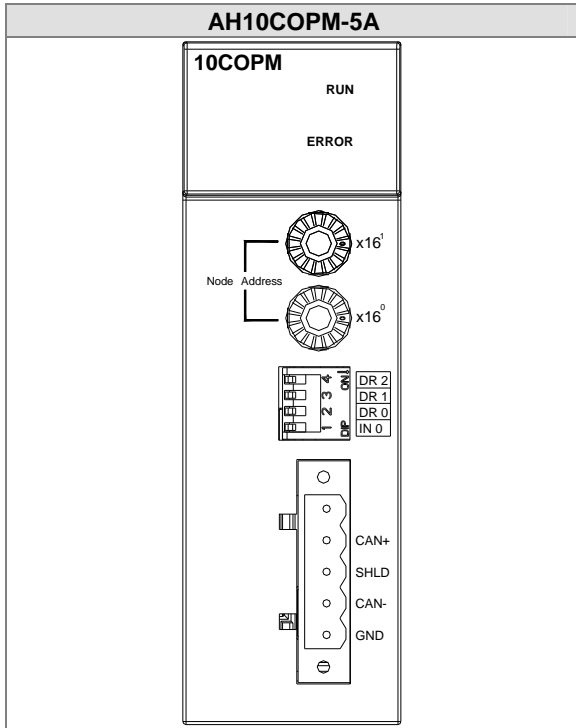

3.9 Specifications for Motion Control Modules

3.9.1 General Specifications

- AH02HC-5A

Item	Specifications	
Number of channels	2 channels	
Input signal	Input (differential input)	CH0: X0.8+, X0.8-, X0.9+, and X0.9- CH1: X0.10+, X0.10-, X0.11+, and X0.11-
	Pulse format	Pulse/Direction (one phase and one input) Counting up/Counting down (one phase and two inputs) One time the frequency of A/B-phase inputs (two phases and two inputs) Four times the frequency of A/B-phase inputs (two phases and two inputs)
	Signal level	5~24 V DC
Specifications	Maximum frequency of counting	The maximum frequency is 200 kHz.
	Range	The number of sampled pulses is in the range of -200000 to 200000. The number of accumulated pulses is in the range of -999999999 to 999999999. The number of input pulses is in the range of -2147483648 to 2147483648.
	Type	General count Circular count
RESET input	Input (differential input)	CH0: X0.0+ and X0.0- CH1: X0.1+ and X0.1-
	Signal level	5~24 V DC
	Maximum current	15 mA

Item		Specifications
Comparison output	Output type	CH0: The high-speed pulse output Y0.8 is a transistor whose collector is an open collector. CH1: The high-speed pulse output Y0.9 is a transistor whose collector is an open collector.
	Signal level	24 V DC
	Maximum current	15 mA

● AH04HC-5A

Item		Specifications
Number of channels		4 channels
Input signal	Input (differential input)	CH0: X0.8+, X0.8-, X0.9+, and X0.9- CH1: X0.10+, X0.10-, X0.11+, and X0.11- CH2: X0.12+, X0.12-, X0.13+, and X0.13- CH3: X0.14+, X0.14-, X0.15+, and X0.15-
	Pulse format	Pulse/Direction (one phase and one input) Counting up/Counting up (one phase and two inputs) One time the frequency of A/B-phase inputs (two phases and two inputs) Four times the frequency of A/B-phase inputs (two phases and two inputs)
	Signal level	5~24 V DC
Specifications	Maximum frequency of counting	The maximum frequency is 200 kHz.
	Range	The number of sampled pulses is in the range of -200000 to 200000. The number of accumulated pulses is in the range of -999999999 to 999999999. The number of input pulses is in the range of -2147483648 to 2147483648.
	Type	Linear count Circular count
RESET input	Input (differential input)	CH0: X0.0+ and X0.0- CH1: X0.1+ and X0.1- CH2: X0.2+ and X0.2- CH3: X0.3+ and X0.3-
	Signal level	5~24V DC
	Maximum current	15 mA
Comparison output	Output type	CH0: The high-speed pulse output Y0.8 is a transistor whose collector is an open collector. CH1: The high-speed pulse output Y0.9 is a transistor whose collector is an open collector. CH2: The high-speed pulse output Y0.10 is a transistor whose collector is an open collector. CH3: The high-speed pulse output Y0.11 is a transistor whose collector is an open collector.
	Signal level	24 V DC
	Maximum current	15 mA

● AH05PM-5A

Item		Specifications		
		AH05PM-5A		
Number of actual axes		2 axes		
Storage		The capacity of the built-in storage is 64K steps.		
Unit		Motor unit	Compound unit	Mechanical unit
Connection with a CPU module		Users can set the initial register involved in the data exchange in a CPU module, and the number of registers involved in the data exchange in the CPU module. Four hundred data registers at most can be involved in the data exchange.		
Motor control		<p>There are three types of pulse output modes. These modes adopt the differential output.</p> <ol style="list-style-type: none"> 1. Pulse/Direction 2. Counting up/Counting down 3. A/B-phase output 		
Maximum speed		<p>Single axis: 1M PPS Multi-axis interpolation: 1M PPS</p>		
Input signal	Detector	X0.0, X0.1, X0.8, X0.9, X0.12, and X0.13		
Output signal	Servo output signal	Y0.0+, Y0.0-, Y0.2+, Y0.2-, Y0.1+, Y0.1-, Y0.3+, Y0.3-, Y0.8, and Y0.9		
External communication port		Mini USB port		
Number of basic instructions		27		
Number of applied instructions		130		
M-code		<ol style="list-style-type: none"> 1. OX0~OX99 (motion subroutine/positioning program): M02 (The execution of the program stops. (END)) 2. M00~M01, M03~M101, and M103~M65535: The execution of the program pauses. (WAIT) Users can use them freely. 		
G-code		G0 (rapid positioning), G1 (linear interpolation), G2 (circular interpolation, clockwise), G3 (circular interpolation, counterclockwise), G4 (dwell), G17 (XY plane selection), G90 (absolute programming), and G91 (incremental programming)		

3

Description of the terminals

Terminal	Description	Response characteristic	Maximum input	
			Current	Voltage
X0.0, X0.1, X0.8, X0.9, X0.12, and X0.13	1. They are single/A/B-phase input terminals. 2. The functions of the terminals: <ul style="list-style-type: none"> ● Motion control: <ul style="list-style-type: none"> ◆ X0.0 is the PG input for axis 1, and X0.1 is the PG input for axis 2. ◆ X0.12 is the DOG input for axis 1, and X0.13 is the DOG input for axis 2. ◆ X0.8 and X0.9 are for a manual pulse generator. ● High-speed count: <ul style="list-style-type: none"> ◆ X0.0 is the RESET input for counter 0. ◆ X0.8 is the A-phase input for counter 0, and X0.9 is the B-phase input for counter 0. ● High-speed comparison and catch: The terminals can function as trigger signals for high-speed catches. ● Interrupt input terminals 	100 kHz (*1)	15 mA	24 V
Y0.8 and Y0.9	1. The high-speed pulse output terminals are transistors whose collectors are open collectors. 2. The functions of the terminals: <ul style="list-style-type: none"> ● Motion control: Y0.8 is the CLEAR output for axis 1, and Y0.9 is the CLEAR output for axis 2. ● High-speed comparison and catch: The high-speed comparison output terminals provide the PWM function. 	200 kHz	15 mA	24 V
Y0.0+, Y0.0-, Y0.1+, Y0.1-, Y0.2+, Y0.2-, Y0.3+, and Y0.3-	1. They are differential output terminals. 2. The function of the terminals: <ul style="list-style-type: none"> ● Motion control: <ul style="list-style-type: none"> ◆ Y0.0+ and Y0.0- are the A-phase output terminals for axis 1. Y0.2+ and Y0.2- are the A-phase output terminals for axis 2. ◆ Y0.1+ and Y0.1- are the B-phase output terminals for axis 1. Y0.3+ and Y0.3- are the B-phase output terminals for axis 2. 	1 MHz	5 mA	5 V

*1. If the frequency of input signals received by an input terminal must be 200 kHz, the input terminal must be connected to a 1 kΩ (2 W) resistor in parallel.

● AH10PM-5A

Item		Specifications		
		AH10PM-5A		
Number of actual axes		6 axes		
Storage		The capacity of the built-in storage is 64K steps.		
Unit		Motor unit	Compound unit	Mechanical unit
Connection with a CPU module		Users can set the initial register involved in the data exchange in a CPU module, and the number of registers involved in the data exchange in the CPU module. Four hundred data registers at most can be involved in the data exchange.		
Motor control		<p>There are three types of pulse output modes. These modes adopt the differential output.</p> <ol style="list-style-type: none"> Pulse/Direction Counting up/Counting down A/B-phase output 		
Maximum speed		Single axis: 1M PPS Multi-axis interpolation: 1M PPS		
Input signal	Operating switch	STOP/RUN (automatic/manual switch)		
	Detector	X0.8, X0.9, X0.10, X0.11, X0.12, X0.13, X0.14, X0.15, X0.0+, X0.0-, X0.1+, X0.1-, X0.2+, X0.2-, X0.3+, and X0.3-		
Output signal	Servo output signal	Y0.0+, Y0.0-, Y0.2+, Y0.2-, Y0.4+, Y0.4-, Y0.6+, Y0.6-, Y0.1+, Y0.1-, Y0.3+, Y0.3-, Y0.5+, Y0.5-, Y0.7+, Y0.7-, Y0.8, Y0.9, Y0.10, and Y0.11		
External communication port		Mini USB port Ethernet port		
Expansion storage device		Mini SD card The maximum capacity is 32 GB.		
Number of basic instructions		27		
Number of applied instructions		130		
M-code		<ol style="list-style-type: none"> OX0~OX99 (motion subroutine/positioning program): M02 (The execution of the program stops. (END)) M00~M01, M03~M101, and M103~M65535: The execution of the program pauses. (WAIT) Users can use them freely. 		
G-code		G0 (rapid positioning), G1 (linear interpolation), G2 (circular interpolation, clockwise), G3 (circular interpolation, counterclockwise), G4 (dwell), G17 (XY plane selection), G18 (ZX plane selection), G19 (YZ plane selection), G90 (absolute programming), and G91 (incremental programming)		

3

Description of the terminals

Terminal	Description	Response characteristic	Maximum input	
			Current	Voltage
X0.0+, X0.0-, X0.1+, X0.1-, X0.2+, X0.2-, X0.3+, and X0.3-	<ol style="list-style-type: none"> They are differential input terminals. The functions of the terminals: <ul style="list-style-type: none"> ● Motion control: They are the PG input terminals for axis 1~axis 4. ● High-speed counter: X0.0+ and X0.0- are the RESET input terminals for counter 0. X0.1+ and X0.1- are the RESET input terminals for counter 1. X0.2+ and X0.2- are the RESET input terminals for counter 2 and counter 4. X0.3+ and X0.3- are the RESET input terminals for counter 3 and counter 5. ● High-speed comparison and catch: The terminals can function as trigger signals for high-speed catches. 	200 kHz	15 mA	5~24 V
X0.8 and X0.9	<ol style="list-style-type: none"> They are single/A/B-phase input terminals. The functions of the terminals: <ul style="list-style-type: none"> ● Motion control: The terminals are for a manual pulse generator. ● High-speed count: <ul style="list-style-type: none"> ◆ The terminals are for counter 0. ◆ X0.8 is the A-phase input for counter 0, and X0.9 is the B-phase input for counter 0. ● High-speed comparison and catch: The terminals can function as trigger signals for high-speed catches. ● Interrupt input terminals 	100 kHz (*1)	15 mA	24 V
X0.10, X0.11, X0.12, X0.13, X0.14, and X0.15	<ol style="list-style-type: none"> They are single/A/B-phase input terminals. The functions of the terminals: <ul style="list-style-type: none"> ● Motion control: They are the DOG input terminals for axis 1~axis 6. ● High-speed counter: <ul style="list-style-type: none"> ◆ The terminals are for counter 1~counter 5. ◆ X0.10 is the A-phase input for counter 1, X0.12 is the A-phase input for counter 2 and counter 4, and X0.14 is the A-phase input for counter 3 and counter 5. ◆ X0.11 is the B-phase input for counter 1, X0.13 is the B-phase input for counter 2 and counter 4, and X0.15 is the B-phase input for counter 3 and counter 5. ● High-speed comparison and catch: The terminals can function as trigger signals for high-speed catches. ● Interrupt input terminals 	100 kHz (*1)	15 mA	24 V

Terminal	Description	Response characteristic	Maximum input	
			Current	Voltage
Y0.8, Y0.9, Y0.10, and Y0.11	<ol style="list-style-type: none"> The high-speed pulse output terminals are transistors whose collectors are open collectors. The functions of the terminals: <ul style="list-style-type: none"> Motion control: <ul style="list-style-type: none"> The terminals are the CLEAR output terminals for axis 1~axis 4, and provide the PWM function. Y0.8 and Y0.9 are for axis 5. Y0.10 and Y0.11 are for axis 6. Y0.8 is the A-phase output for axis 5, and Y0.10 is the A-phase output for axis 6. Y0.9 is the B-phase output for axis 5, and Y0.11 is the B-phase output for axis 6. High-speed comparison and catch: The terminals can function as high-speed comparison output terminals. 	200 kHz	15 mA	24 V
Y0.0+, Y0.0-, Y0.1+, Y0.1-, Y0.2+, Y0.2-, Y0.3+, Y0.3-, Y0.4+, Y0.4-, Y0.5+, Y0.5-, Y0.6+, Y0.6-, Y0.7+, and Y0.7-	<ol style="list-style-type: none"> They are differential output terminals. The function of the terminals: <ul style="list-style-type: none"> Motion control: <ul style="list-style-type: none"> The terminals are for axis 1~axis 4. Y0.0+ and Y0.0- are the A-phase output terminals for axis 1. Y0.2+ and Y0.2- are the A-phase output terminals for axis 2. Y0.4+ and Y0.4- are the A-phase output terminals for axis 3. Y0.6+ and Y0.6- are the A-phase output terminals for axis 4. Y0.1+ and Y0.1- are the B-phase output terminals for axis 1. Y0.3+ and Y0.3- are the B-phase output terminals for axis 2. Y0.5+ and Y0.5- are the B-phase output terminals for axis 3. Y0.7+ and Y0.7- are the B-phase output terminals for axis 4. Y0.0+ and Y0.0- are the CLEAR output terminals for axis 5. Y0.1+ and Y0.1- are the CLEAR output terminals for axis 6. 	1 MHz	5 mA	5 V

*1. If the frequency of input signals received by an input terminal must be 200 kHz, the input terminal must be connected to a 1 k Ω (2 W) resistor in parallel.

● AH15PM-5A

Item		AH15PM-5A		
Number of actual axes		4 axes		
Storage		The capacity of the built-in storage is 64K steps.		
Unit		Motor unit	Compound unit	Mechanical unit
Connection with a CPU module		Users can set the initial register involved in the data exchange in a CPU module, and the number of registers involved in the data exchange in the CPU module. Four hundred data registers at most can be involved in the data exchange.		
Motor control		There are three types of pulse output modes. These modes adopt the differential output. 1. Pulse/Direction 2. Counting up/Counting down 3. A/B-phase output		
Maximum speed		Single axis: 1M PPS Multi-axis interpolation: 1M PPS		
Input signal	Operating switch	STOP/RUN (automatic/manual switch)		
	Detector	X0.0+, X0.0-, X0.1+, X0.1-, X0.2+, X0.2-, X0.3+, and X0.3-, X0.4, X0.5, X0.6, X0.7, X0.10, X0.11, X0.12, X0.13, X0.14, X0.15, X1.0, X1.1		
Output signal	Servo output signal	Y0.0+, Y0.0-, Y0.2+, Y0.2-, Y0.4+, Y0.4-, Y0.6+, Y0.6-, Y0.1+, Y0.1-, Y0.3+, Y0.3-, Y0.5+, Y0.5-, Y0.7+, Y0.7-, Y0.8, Y0.9, Y0.10, and Y0.11		
External communication port		Mini USB port Ethernet port		
Expansion storage device		Mini SD card The maximum capacity is 32 GB.		
Number of basic instructions		27		
Number of applied instructions		130		
M-code		1. OX0~OX99 (motion subroutine/positioning program): M02 (The execution of the program stops. (END)) 2. M00~M01, M03~M101, and M103~M65535: The execution of the program pauses. (WAIT) Users can use them freely.		
G-code		G0 (rapid positioning), G1 (linear interpolation), G2 (circular interpolation, clockwise), G3 (circular interpolation, counterclockwise), G4 (dwell), G17 (XY plane selection), G18 (ZX plane selection), G19 (YZ plane selection), G90 (absolute programming), and G91 (incremental programming)		

Description of the terminals

Terminal	Description	Response characteristic	Maximum input	
			Current	Voltage
X0.0+, X0.0-, X0.1+, X0.1-, X0.2+, X0.2-, X0.3+, and X0.3-	<ol style="list-style-type: none"> They are differential input terminals. The functions of the terminals: <ul style="list-style-type: none"> ● Motion control: They are the PG input terminals for axis 1~axis 4. ● High-speed counter: X0.0+ and X0.0- are the RESET input terminals for counter 0. X0.1+ and X0.1- are the RESET input terminals for counter 1. X0.2+ and X0.2- are the RESET input terminals for counter 2 and counter 4. X0.3+ and X0.3- are the RESET input terminals for counter 3 and counter 5. ● High-speed comparison and catch: The terminals can function as trigger signals for high-speed catches. ● Interrupt input terminals 	200 kHz	15 mA	5~24 V
X0.4, X0.5, X0.6, and X0.7	<ol style="list-style-type: none"> They are single/A/B-phase input terminals. The functions of the terminals: <ul style="list-style-type: none"> ● Motion control: They are the DOG input terminals for axis 1~axis 4. 	100 kHz (*1)	15 mA	24 V
X0.8+, X0.8-, X0.9+, and X0.9-	<ol style="list-style-type: none"> They are differential input terminals. The functions of the terminals: <ul style="list-style-type: none"> ● Motion control: The terminals are for a manual pulse generator. ● High-speed count: <ul style="list-style-type: none"> ◆ The terminals are for counter 0. ◆ X0.8+ and X0.8- are the A-phase input terminals for counter 0, and X0.9+ and X0.9- are the B-phase input terminals for counter 0. ● High-speed comparison and catch: The terminals can function as trigger signals for high-speed catches. ● Interrupt input terminals 	200 kHz	15 mA	5~24 V

Terminal	Description	Response characteristic	Maximum input	
			Current	Voltage
X0.10, X0.11, X0.12, X0.13, X0.14, X0.15, X1.0, and X1.1	<ol style="list-style-type: none"> 1 They are differential input terminals. 2 The functions of the terminals: <ul style="list-style-type: none"> ● Motion control: X0.10 is LSP0, X0.11 is LSN0, X0.12 is LSP1, X0.13 is LSN1, X0.14 is LSP2, X0.15 is LSN2, X1.0 is LSP3, and X1.1 is LSN3. ● High-speed count: <ul style="list-style-type: none"> ◆ The terminals are for counter 1~counter 5. ◆ X0.10 is the A-phase input for counter 1. X0.12 is the A-phase input for counter 2 and counter 4. X0.14 is the A-phase input for counter 3 and counter 5. ◆ X0.11 is the B-phase input for counter 1. X0.13 is the B-phase input for counter 2 and counter 4. X0.15 is the B-phase input for counter 3 and counter 5. ● High-speed comparison and catch: The terminals can function as trigger signals for high-speed catches. ● Interrupt input terminals: X0.10~X0.15 	100 kHz (*1)	15 mA	24 V
X1.2, X1.3, X1.4, and X1.5	<ol style="list-style-type: none"> 1. They are single/A/B-phase input terminals. 	100 kHz (*1)	15 mA	24 V
Y0.8, Y0.9, Y0.10, and Y0.11	<ol style="list-style-type: none"> 1. The high-speed pulse output terminals are transistors whose collectors are open collector. 2. The function of the terminals: <ul style="list-style-type: none"> ● Motion control: The terminals are the CLEAR output terminals for axis 1~axis 4. ● High-speed comparison and catch: The terminals can function as high-speed comparison output terminals. 	200 kHz	15 mA	24 V

Terminal	Description	Response characteristic	Maximum input	
			Current	Voltage
Y0.0+, Y0.0-, Y0.1+, Y0.1-, Y0.2+, Y0.2-, Y0.3+, Y0.3-, Y0.4+, Y0.4-, Y0.5+, Y0.5-, Y0.6+, Y0.6-, Y0.7+, and Y0.7-	1. They are differential output terminals. 2. The function of the terminals: <ul style="list-style-type: none"> ● Motion control: <ul style="list-style-type: none"> ◆ The terminals are for axis 1~axis 4. ◆ Y0.0+ and Y0.0- are the A-phase output terminals for axis 1. Y0.2+ and Y0.2- are the A-phase the output terminals for axis 2. Y0.4+ and Y0.4- are the A-phase output terminals for axis 3. Y0.6+ and Y0.6- are the A-phase output terminals for axis 4. ◆ Y0.1+ and Y0.1- are the B-phase output terminals for axis 1. Y0.3+ and Y0.3- are the B-phase output terminals for axis 2. Y0.5+ and Y0.5- are the B-phase output terminals for axis 3. Y0.7+ and Y0.7- are the B-phase output terminals for axis 4. ◆ Y0.0+ and Y0.0- are the CLEAR output terminals for axis 5. Y0.1+ and Y0.1- are the CLEAR output terminals for axis 6. 	1 MHz	5 mA	5 V

*1. If the frequency of input signals received by an input terminal must be 200 kHz, the input terminal must be connected to a 1 k Ω (2 W) resistor in parallel.

● AH20MC-5A

Item	Specifications		
	AH20MC-5A		
Number of actual axes	12 axes		
Storage	The capacity of the built-in storage is 64K steps.		
Unit	Motor unit	Compound unit	Mechanical unit
Connection with a CPU module	Users can set the initial register involved in the data exchange in a CPU module, and the number of registers involved in the data exchange in the CPU module. Four hundred data registers at most can be involved in the data exchange.		
Motor control	Delta high-speed motion control system DMCNET (Delta Motion Control Network) The response time is one millisecond.		
Maximum speed	Single axis: 1M PPS Two-axis interpolation: 1M PPS		
Input signal	Operating switch	STOP/RUN (automatic/manual switch)	
	Detector	X0.10+, X0.10-, X0.11+, X0.11-, X0.12+, X0.12-, X0.13+, X0.13-, X0.14+, X0.14-, X0.15+, X0.15-, X0.0+, X0.0-, X0.1+, X0.1-, X0.2+, X0.2-, X0.3+, X0.3-	
Output signal	Servo output signal	Y0.8, Y0.9, Y0.10, Y0.11	
External communication port	Mini USB port Ethernet port DMCNET port		
Expansion storage device	Mini SD card The maximum capacity is 32 GB.		
Number of basic instructions	27		

Item	Specifications
	AH20MC-5A
Number of applied instructions	130
M-code	<ul style="list-style-type: none"> OX0~OX99 (motion subroutine/positioning program): M02 (The execution of the program stops. (END)) M00~M01, M03~M101, and M103~M65535: The execution of the program pauses. (WAIT) Users can use them freely.
G-code	G0 (rapid positioning), G1 (linear interpolation), G2 (circular interpolation, clockwise), G3 (circular interpolation, counterclockwise), G4 (dwell), G17 (XY plane selection), G18 (ZX plane selection), G19 (YZ plane selection), G90 (absolute programming), and G91 (incremental programming)

Description of the terminals

Terminal	Description	Response characteristic	Maximum input	
			Current	Voltage
X0.0+, X0.0-, X0.1+, X0.1-, X0.2+, X0.2-, X0.3+, and X0.3-	<ol style="list-style-type: none"> They are differential input terminals. The functions of the terminals: <ul style="list-style-type: none"> High-speed count: <ul style="list-style-type: none"> The terminals are the RESET input terminals for counter 0~counter 5. X0.0+ and X0.0- are for counter 0. X0.1+ and X0.1- are for counter 1. X0.2+ and X0.2- are for counter 2 and counter 4. X0.3+ and X0.3- are for counter 3 and counter 5. High-speed comparison and catch: The terminals can function as trigger signals for high-speed catches. Interrupt input terminals 	200 kHz	15 mA	5~24 V
X0.8+, X0.8-, X0.9+, and X0.9-	<ol style="list-style-type: none"> They are differential input terminals. The functions of the terminals: <ul style="list-style-type: none"> Motion control: The terminals are for a manual pulse generator. High-speed count: <ul style="list-style-type: none"> The terminals are for counter 0. X0.8+ and X0.8- are the A-phase input terminals for counter 0. X0.9+ and X0.9- are the B-phase input terminals for counter 0. High-speed comparison and catch: The terminals can function as trigger signals for high-speed catches. Interrupt input terminals 	200 kHz	15 mA	5~24 V

3

3

Terminal	Description	Response characteristic	Maximum input	
			Current	Voltage
X0.10+, X0.10-, X0.11+, X0.11-, X0.12+, X0.12-, X0.13+, X0.13-, X0.14+, X0.14-, X0.15+, and X0.15-	1. They are differential input terminals. 2. The functions of the terminals: <ul style="list-style-type: none"> ● High-speed count: <ul style="list-style-type: none"> ◆ The terminals are for counter 1~counter 5. ◆ X0.10+ and X0.10- are the A-phase input terminals for counter 1. X0.12+ and X0.12- are the A-phase input terminals for counter 2 and counter 4. X0.14+ and X0.14- are the A-phase input terminals for counter 3 and counter 5. ◆ X0.11+ and X0.11- are the B-phase input terminals for counter 1. X0.13+ and X0.13- are the B-phase input terminals for counter 2 and counter 4. X0.15+ and X0.15- are the B-phase input terminals for counter 3 and counter 5. ● High-speed comparison and catch: The terminals can function as trigger signals for high-speed catches. ● Interrupt input terminals 	200 kHz	15 mA	5~24 V
Y0.8, Y0.9, Y0.10, and Y0.11	1. The high-speed pulse output terminals are transistors whose collectors are open collectors. 2. The function of the terminals: <ul style="list-style-type: none"> ● High-speed comparison and catch: The terminals can function as high-speed comparison output terminals. 	200 kHz	15 mA	24 V

3.9.2 Profiles

● AH02HC-5A

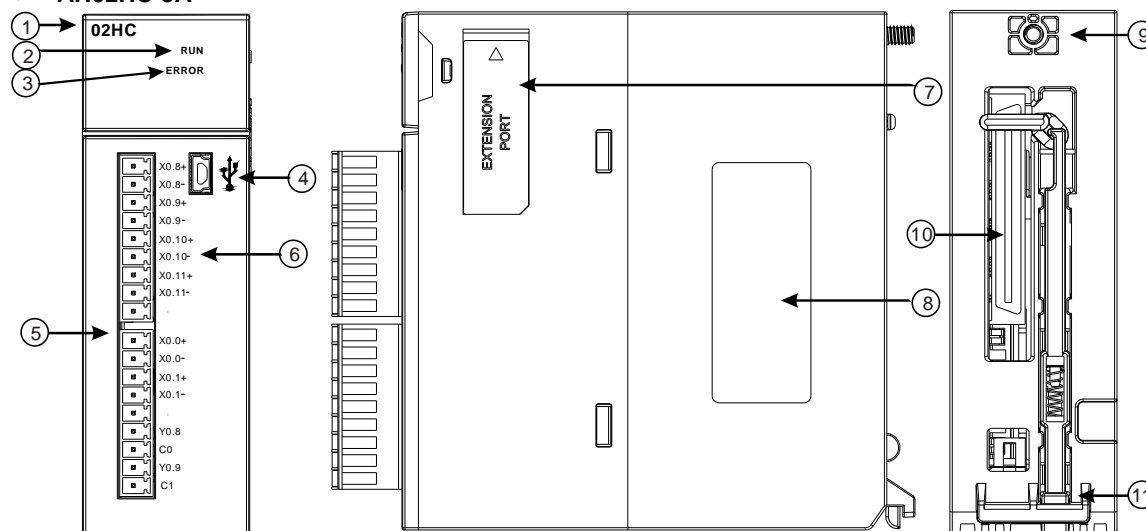

Number	Name	Description
1	Model name	Model name of the module

Number	Name	Description
2	RUN LED indicator (green)	Operating status of the module ON: The module is running. OFF: The module stops running.
3	ERROR LED indicator (red)	Error status of the module Blinking: The module is abnormal.
4	USB port	Providing the mini USB communication interface
5	Terminals	Input/Output terminals
6	Arrangement of the input/output terminals	Arrangement of the terminals
7	Extension port	Updating the firmware
8	Label	Nameplate
9	Set screw	Fixing the module
10	Connector	Connecting the module and a backplane
11	Projection	Fixing the module

● AH04HC-5A

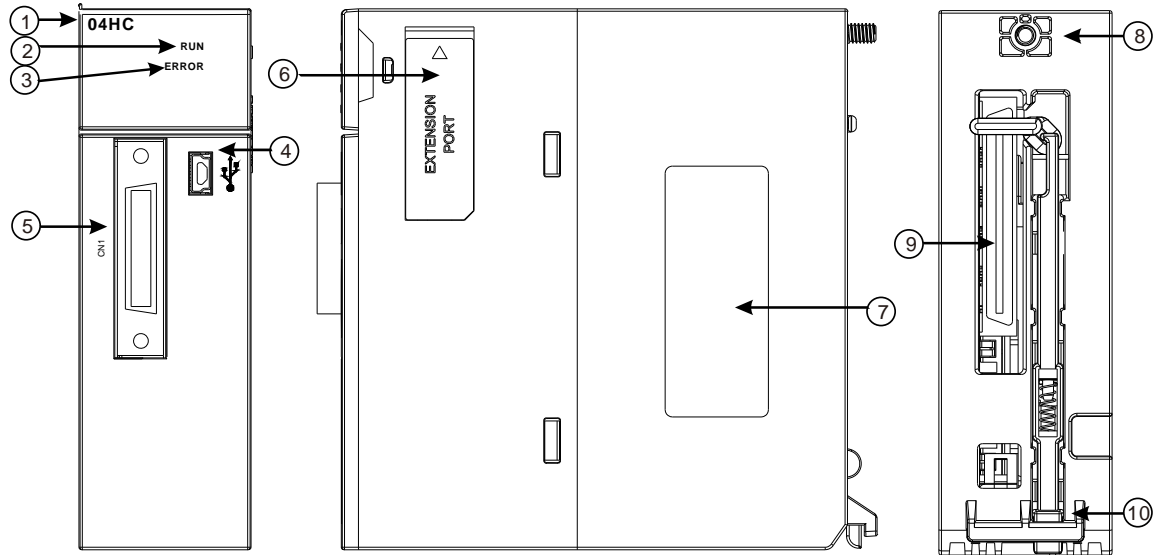

Number	Name	Description
1	Model name	Model name of the module
2	RUN LED indicator (green)	Operating status of the module ON: The module is running. OFF: The module stops running.
3	ERROR LED indicator (red)	Error status of the module Blinking: The module is abnormal.
4	USB port	Providing the mini USB communication interface
5	Connector	Connecting the module and an I/O extension cable
6	Extension port	Updating the firmware
7	Label	Nameplate
8	Set screw	Fixing the module
9	Connector	Connecting the module and a backplane
10	Projection	Fixing the module

3

● AH05PM-5A

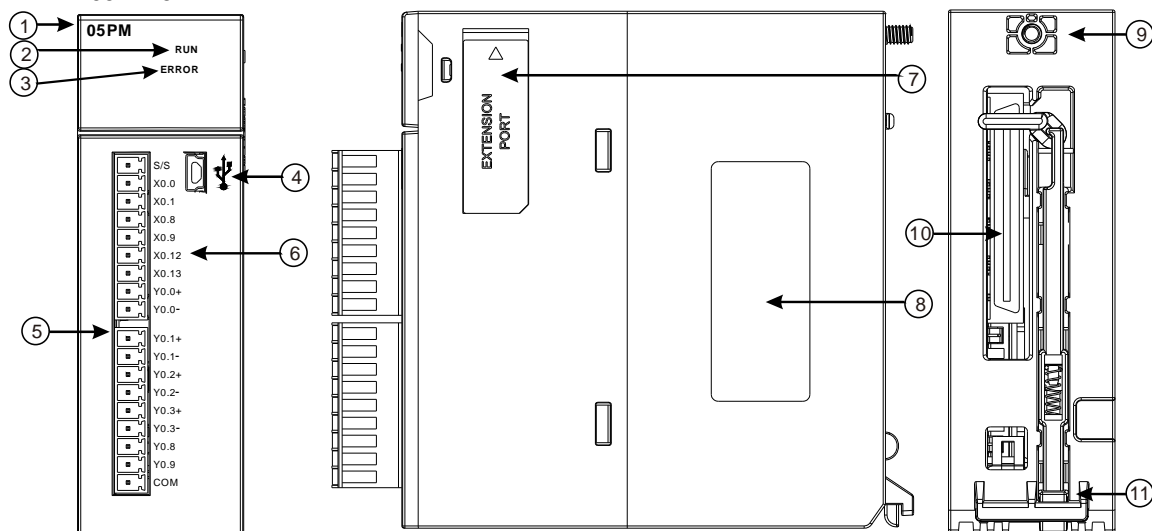

Number	Name	Description
1	Model name	Model name of the module
2	RUN LED indicator (green)	Operating status of the module ON: The module is running. OFF: The module stops running.
3	ERROR LED indicator (red)	Error status of the module Blinking: The module is abnormal.
4	USB port	Providing the mini USB communication interface
5	Terminals	Input/Output terminals
6	Arrangement of the input/output terminals	Arrangement of the terminals
7	Extension port	Updating the firmware
8	Label	Nameplate
9	Set screw	Fixing the module
10	Connector	Connecting the module and a backplane
11	Projection	Fixing the module

● AH10PM-5A

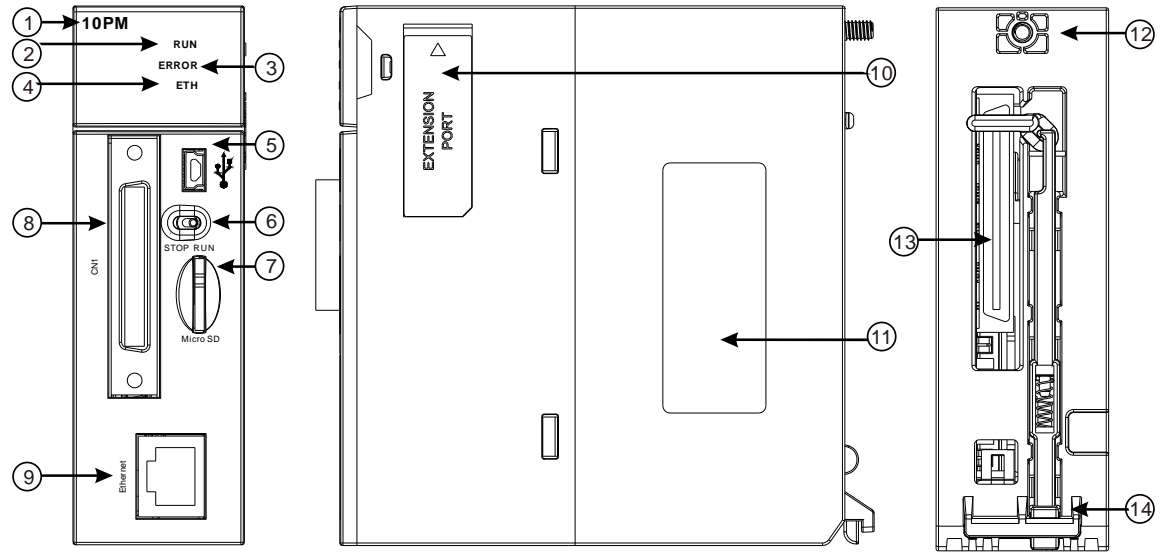

Number	Name	Description
1	Model name	Model name of the module
2	RUN LED indicator (green)	Operating status of the module ON: The module is running. OFF: The module stops running.
3	ERROR LED indicator (red)	Error status of the module Blinking: The module is abnormal.
4	Ethernet connection LED indicator (green)	Status of the Ethernet connection ON: The Ethernet connection is being connected. OFF: The Ethernet connection is disconnected.
5	USB port	Providing the mini USB communication interface
6	RUN/STOP switch	RUN: The user program is executed. STOP: The execution of the user program stops.
7	SD slot	Providing the SD interface
8	Connector	Connecting the module and an I/O extension cable
9	Ethernet port	Providing the Ethernet communication interface
10	Extension port	Updating the firmware
11	Label	Nameplate
12	Set screw	Fixing the module
13	Connector	Connecting the module and a backplane
14	Projection	Fixing the module

3

3

● AH15PM-5A

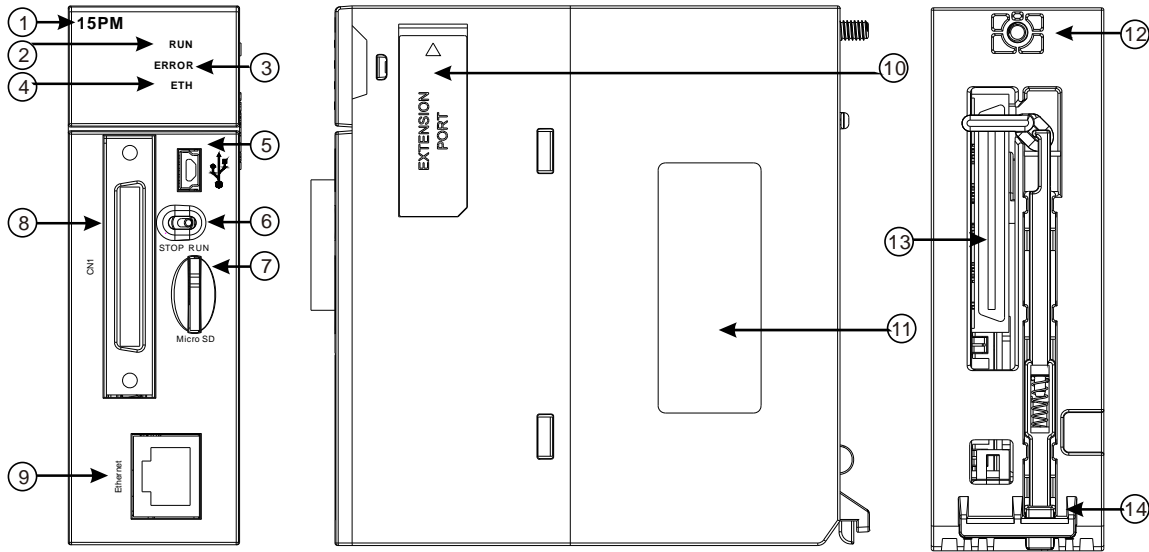

Number	Name	Description
1	Model name	Model name of the module
2	RUN LED indicator (green)	Operating status of the module ON: The module is running. OFF: The module stops running.
3	ERROR LED indicator (red)	Error status of the module Blinking: The module is abnormal.
4	Ethernet connection LED indicator (green)	Status of the Ethernet connection ON: The Ethernet connection is being connected. OFF: The Ethernet connection is disconnected.
5	USB port	Providing the mini USB communication interface
6	RUN/STOP switch	RUN: The user program is executed. STOP: The execution of the user program stops.
7	SD slot	Providing the SD interface
8	Connector	Connecting the module and an I/O extension cable
9	Ethernet port	Providing the Ethernet communication interface
10	Extension port	Updating the firmware
11	Label	Nameplate
12	Set screw	Fixing the module
13	Connector	Connecting the module and a backplane
14	Projection	Fixing the module

● AH20MC-5A

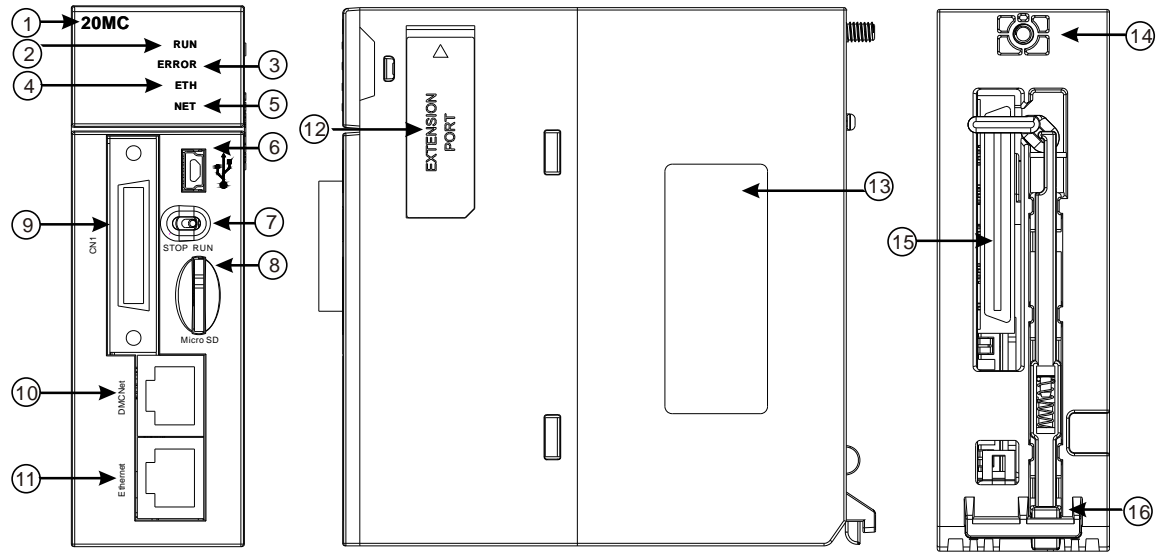

3

Number	Name	Description
1	Model name	Model name of the module
2	RUN LED indicator (green)	Operating status of the module ON: The module is running. OFF: The module stops running.
3	ERROR LED indicator (red)	Error status of the module Blinking: The module is abnormal.
4	Ethernet connection LED indicator (green)	Status of the Ethernet connection ON: The Ethernet connection is being connected. OFF: The Ethernet connection is disconnected.
5	DMCNET connection LED indicator (green)	Status of the DMCNET connection ON: The DMCNET connection is being connected. OFF: The DMCNET connection is disconnected.
6	USB port	Providing the mini USB communication interface
7	RUN/STOP switch	RUN: The user program is executed. STOP: The execution of the user program stops.
8	SD slot	Providing the SD interface
9	Connector	Connecting the module and an I/O extension cable.
10	DMCNET port	Providing the DMCNET communication interface
11	Ethernet port	Providing the Ethernet communication interface
12	Extension port	For updating the firmware
13	Label	Nameplate
14	Set screw	Fixing the module
15	Connector	Connecting the module and a backplane
16	Projection	Fixing the module

● I/O extension cable, and external terminal module

1. I/O extension cable DVPACAB7D10/DVPACAB7E10

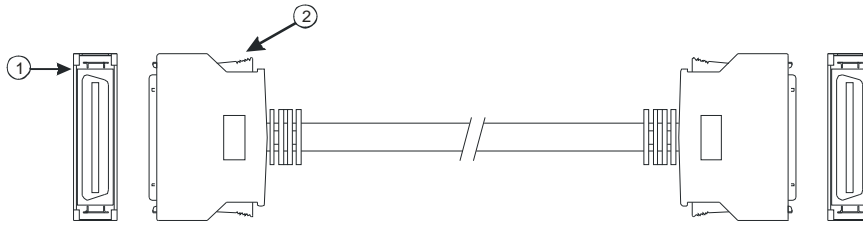

Number	Name	Description
1	Connector	Connecting a motion control module and an external terminal module DVPACAB7D10 is a 36-pin I/O extension cable for AH04HC-5A and AH20MC-5A. DVPACAB7E10 is a 50-pin I/O extension cable for AH10PM-5A and AH15PM-5A.
2	Clip	Fixing the connector

2. External terminal module for AH04HC-5A and AH20MC-5A: DVPAETB-IO16C

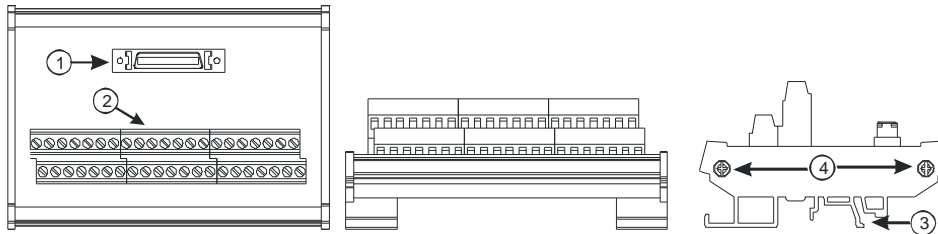

3. External terminal module for AH10PM-5A: DVPAETB-IO24C

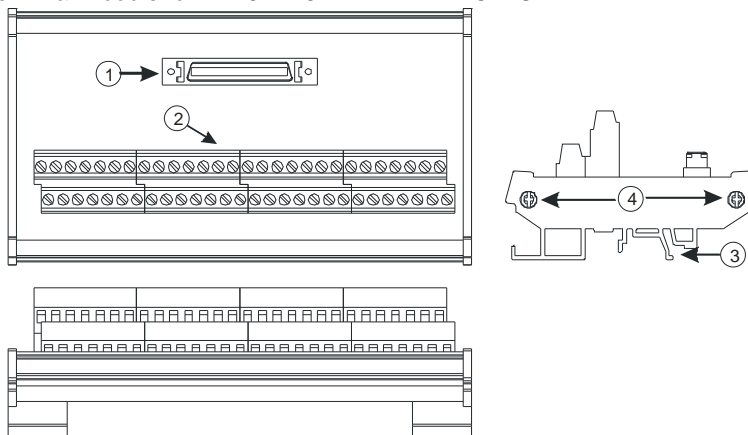

3

4. External terminal module for AH15PM-5A: DVPAETB-IO34C

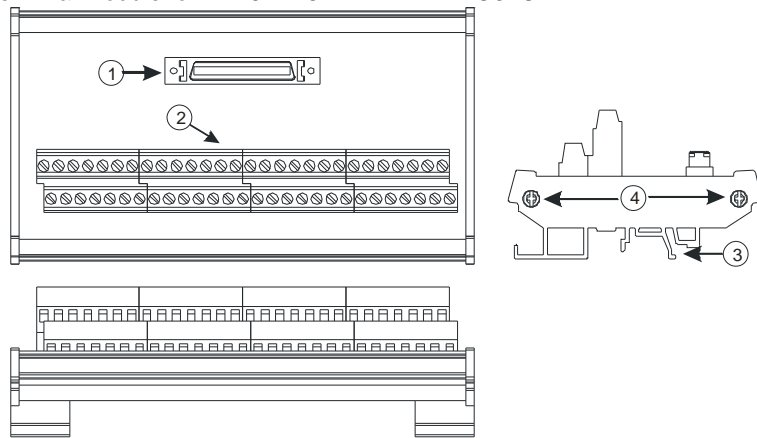

Number	Name	Description
1	Connector	Connecting the external terminal module and a motion control module
2	Terminals	Input/Output terminals for wiring
3	Clip	Hanging the external terminal module on a DIN rail
4	Set screw	Fixing the base

3.9.3 Dimensions

● AH02HC-5A

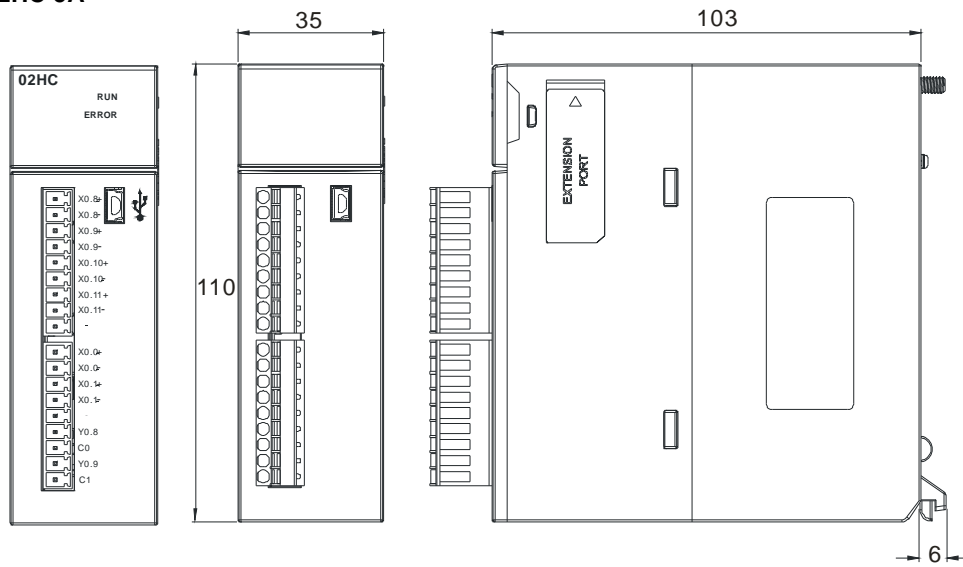

Unit: mm

3

3

● AH04HC-5A

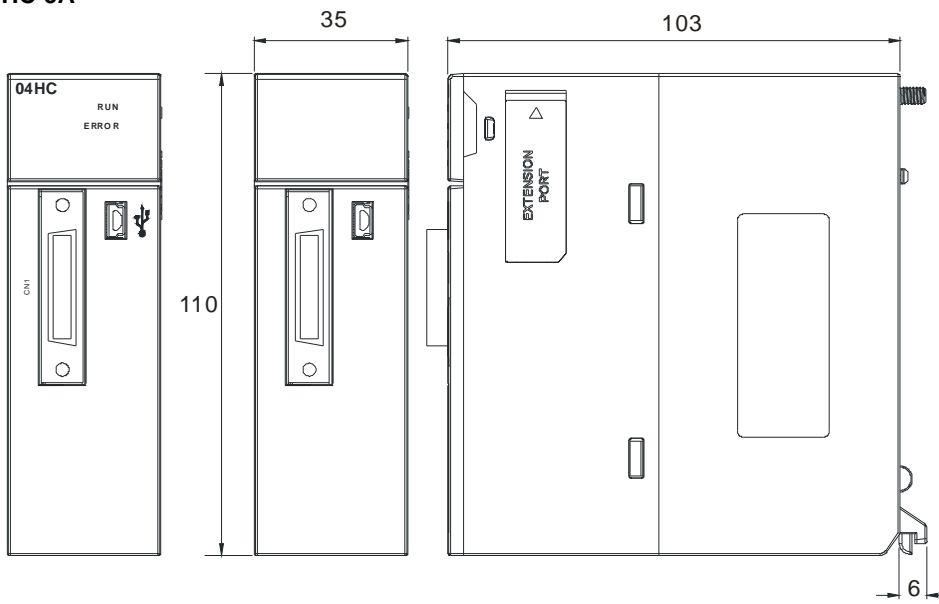

Unit: mm

● AH05PM-5A

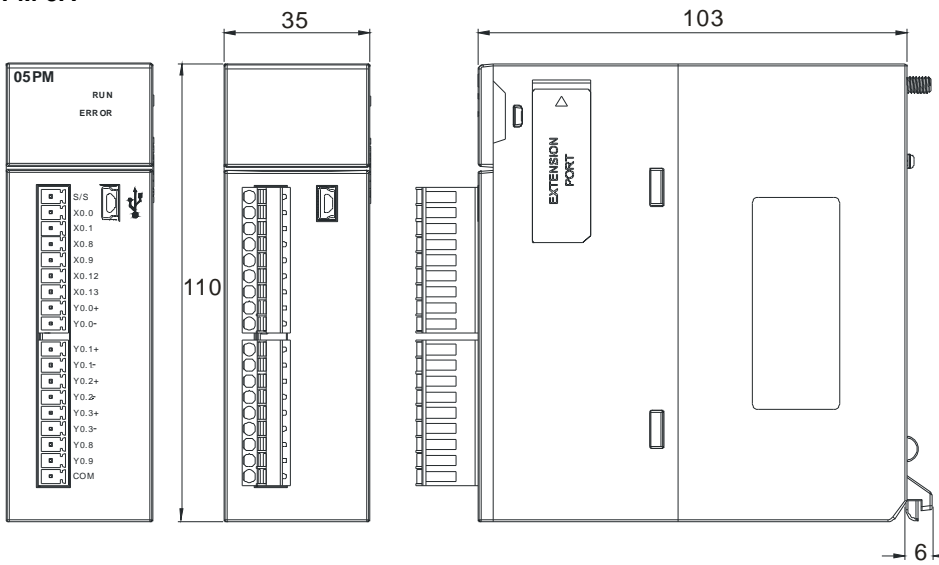

Unit: mm

● AH10PM-5A

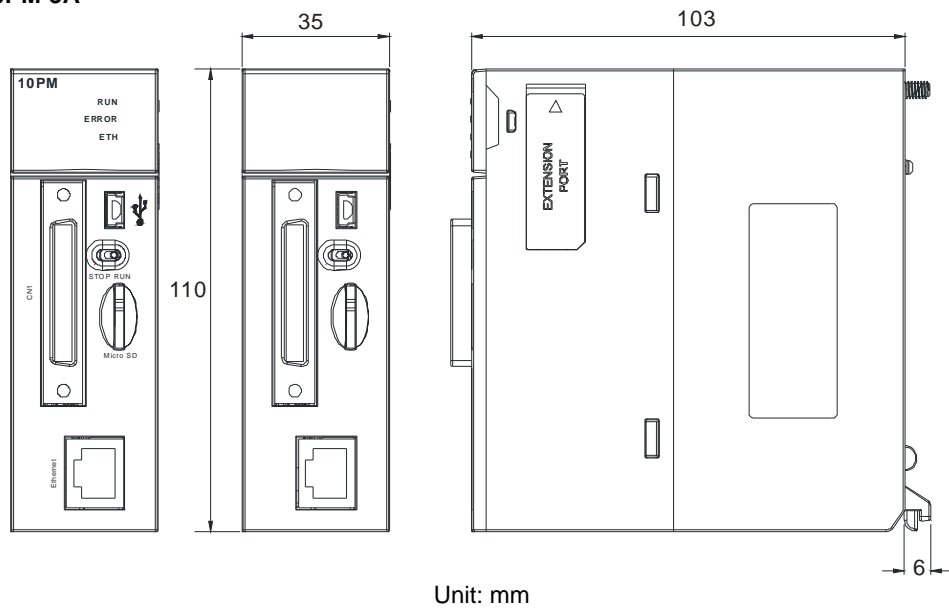

Unit: mm

● AH15PM-5A

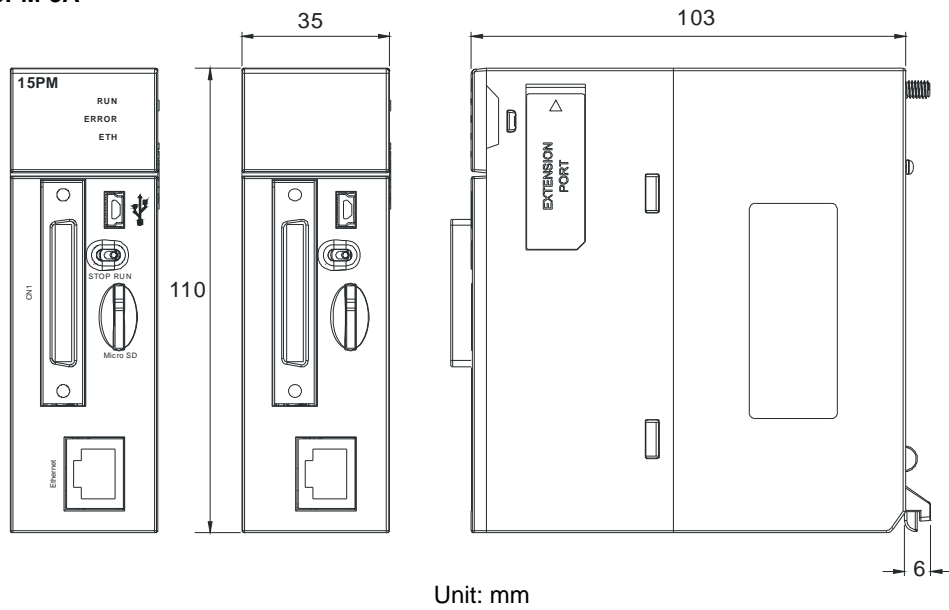

Unit: mm

● AH20MC-5A

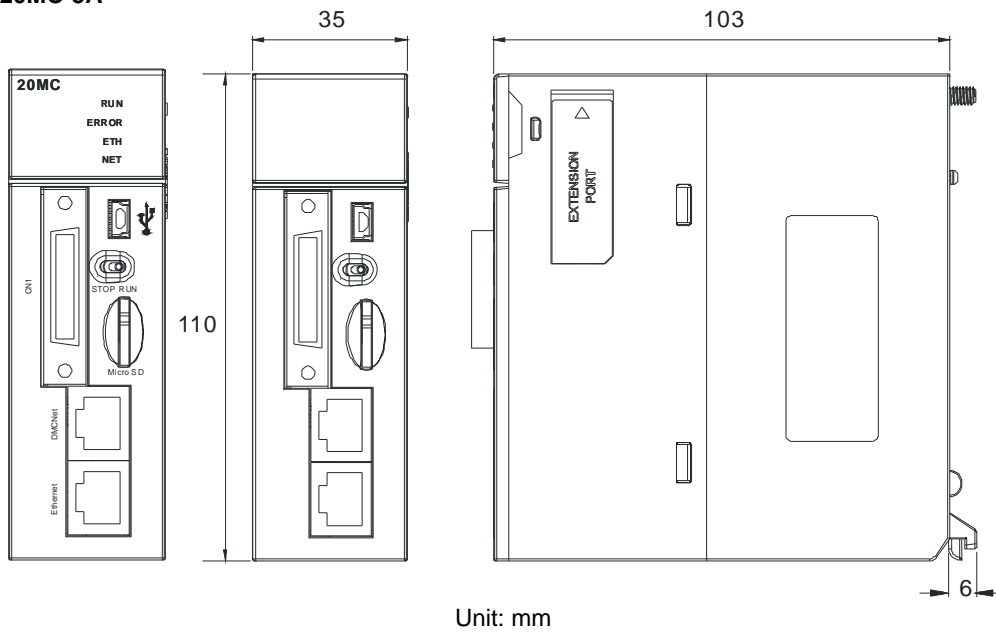

Unit: mm

● I/O extension cable, and external terminal module

1. 36-pin I/O extension cable for AH04HC-5A and AH20MC-5: DVPACAB7D10

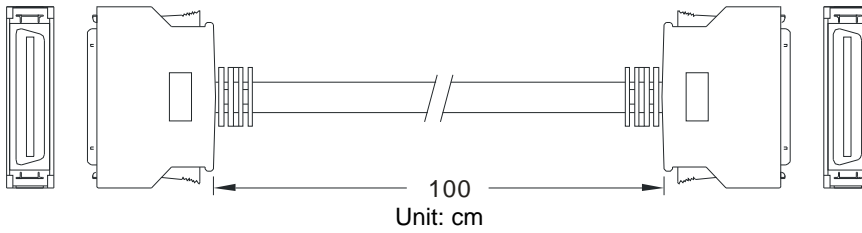

2. External terminal module for AH04HC-5A and AH20MC-5A: DVPAETB-IO16C

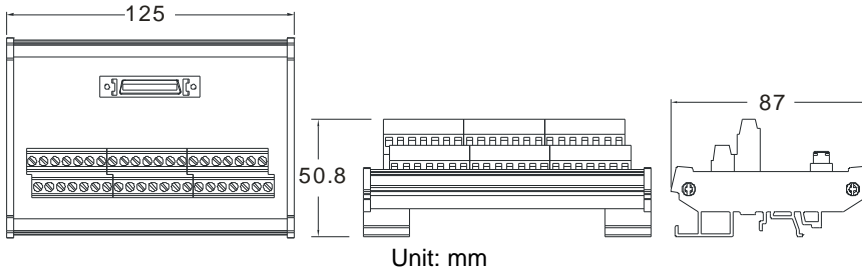

3. 50-pin I/O extension cable for AH10PM-5A and AH15PM-5A: DVPACAB7E10

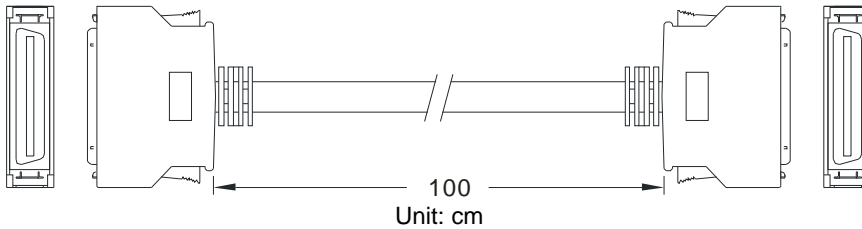

4. External terminal module for AH10PM-5A: DVPAETB-IO24C

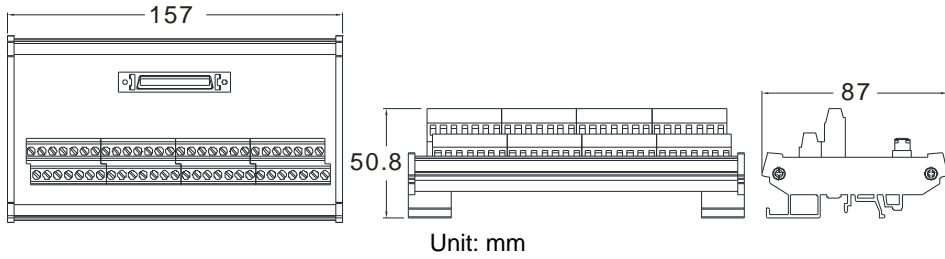

5. External terminal module for AH15PM-5A: DVPAETB-IO34C

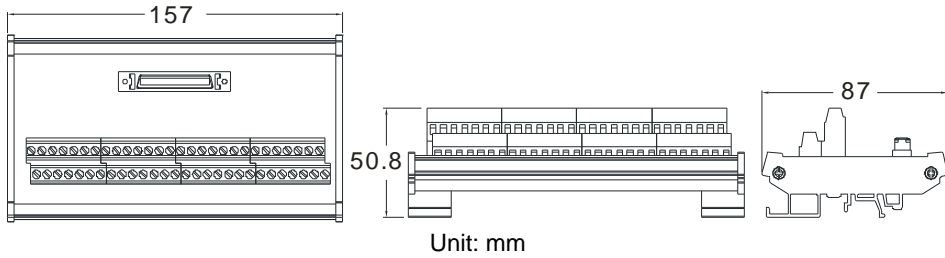

3

3.9.4 Arrangement of Input/Output Terminals

● AH02HC-5A

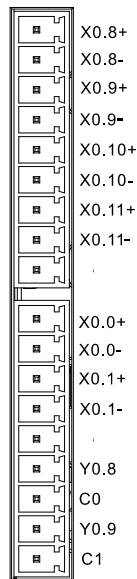

Terminal	Function	Terminal	Function
	Count		Count
X0.8+	CntA0+	X0.0+	Rst0+
X0.8-	CntA0-	X0.0-	Rst0-
X0.9+	CntB0+	X0.1+	Rst1+
X0.9-	CntB0-	X0.1-	Rst1-
X0.10+	CntA1+	Y0.8	Out0
X0.10-	CntA1-	C0	COM0
X0.11+	CntB1+	Y0.9	Out1
X0.11-	CntB1-	C1	COM1

● AH04HC-5A

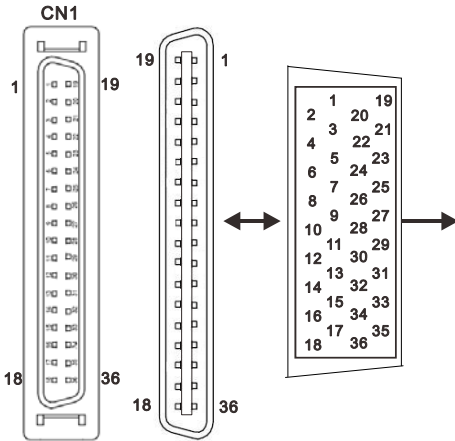

Pin	Terminal	Function Count	Pin	Terminal	Function Count
1	C3	COM3	19	Y0.11	Out3
2	C2	COM2	20	Y0.10	Out2
3	C1	COM1	21	Y0.9	Out1
4	C0	COM0	22	Y0.8	Out0
5	-	-	23	-	-
6	-	-	24	-	-
7	X0.3-	Rst3-	25	X0.3+	Rst3+
8	X0.15-	CntB3-	26	X0.15+	CntB3+
9	X0.14-	CntA3-	27	X0.14+	CntA3+
10	X0.2-	Rst2-	28	X0.2+	Rst2+
11	X0.13-	CntB2-	29	X0.13+	CntB2+
12	X0.12-	CntA2-	30	X0.12+	CntA2+
13	X0.1-	Rst1-	31	X0.1+	Rst1+
14	X0.11-	CntB1-	32	X0.11+	CntB1+
15	X0.10-	CntA1-	33	X0.10+	CntA1+
16	X0.0-	Rst0-	34	X0.0+	Rst0+
17	X0.9-	CntB0-	35	X0.9+	CntB0+
18	X0.8-	CntA0-	36	X0.8+	CntA0+

● AH05PM-5A

Terminal	Function		Terminal	Function	
	Pulse	Count		Pulse	Count
S/S	S/S	S/S	Y0.1+	B0+	-
X0.0	PG0	Rst0	Y0.1-	B0-	-
X0.1	PG1	-	Y0.2+	A1+	-
X0.8	MPGA	CntA0	Y0.2-	A1-	-
X0.9	MPGB	CntB0	Y0.3+	B1+	-
X0.12	DOG0	-	Y0.3-	B1-	-
X0.13	DOG1	-	Y0.8	CLR0	-
Y0.0+	A0+	-	Y0.9	CLR1	-
Y0.0-	A0-	-	COM	-	-

● AH10PM-5A

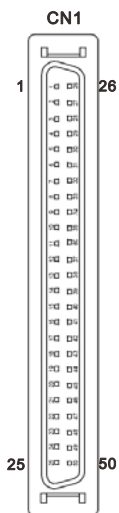

Pin	Terminal	Function		Pin	Terminal	Function	
		Pulse	Count			Pulse	Count
1	C3	COM3	-	26	Y0.11	CLR3/B5	-
2	C2	COM2	-	27	Y0.10	CLR2/A5	-
3	C1	COM1	-	28	Y0.9	CLR1/B4	-
4	C0	COM0	-	29	Y0.8	CLR0/A4	-
5	NC	-	-	30	NC	-	-
6	Y0.7-	B3-	-	31	Y0.7+	B3+	-
7	Y0.6-	A3-	-	32	Y0.6+	A3+	-
8	Y0.5-	B2-	-	33	Y0.5+	B2+	-
9	Y0.4-	A2-	-	34	Y0.4+	A2+	-
10	Y0.3-	B1-	-	35	Y0.3+	B1+	-
11	Y0.2-	A1-	-	36	Y0.2+	A1+	-
12	Y0.1-	B0-/CLR5-	-	37	Y0.1+	B0+/CLR5+	-
13	Y0.0-	A0-/CLR4-	-	38	Y0.0+	A0+/CLR4+	-
14	NC	-	-	39	NC	-	-
15	NC	-	-	40	S/S	S/S	S/S
16	X0.15	DOG3	CntB3/CntB5	41	X0.14	DOG2	CntB3/CntA5
17	X0.13	DOG1	CntB2/CntB4	42	X0.12	DOG0	CntA2/CntA4
18	X0.11	DOG5	CntB1	43	X0.10	DOG4	CntA1
19	X0.9	MPGB	CntB0	44	X0.8	MPGA	CntA0
20	NC	-	-	45	NC	-	-
21	NC	-	-	46	NC	-	-
22	X0.3-	Pg3-	Rst3-/Rst5-	47	X0.3+	Pg3+	Rst3+/Rst5+
23	X0.2-	Pg2-	Rst2-/Rst4-	48	X0.2+	Pg2+	Rst2+/Rst4+
24	X0.1-	Pg1-	Rst1-	49	X0.1+	Pg1+	Rst1+
25	X0.0-	Pg0-	Rst0-	50	X0.0+	Pg0+	Rst0+

3

● AH15PM-5A

Pin	Terminal	Function		Pin	Terminal	Function	
		Pulse	Count			Pulse	Count
1	Y0.11	CLR3	-	26	Y0.10	CLR2	-
2	Y0.9	CLR1	-	27	Y0.8	CLR0	-
3	COM	COM	-	28	Y0.7+	B3+	-
4	Y0.7-	B3-	-	29	Y0.6+	A3+	-
5	Y0.6-	A3-	-	30	Y0.5+	B2+	-
6	Y0.5-	B2-	-	31	Y0.4+	A2+	-
7	Y0.4-	A2-	-	32	Y0.3+	B1+	-
8	Y0.3-	B1-	-	33	Y0.2+	A1+	-
9	Y0.2-	A1-	-	34	Y0.1+	B0+	-
10	Y0.1-	B0-	-	35	Y0.0+	A0+	-
11	Y0.0-	A0-	-	36	S/S	S/S	S/S
12	X1.5	CHG3	-	37	X1.4	CHG2	-
13	X1.3	CHG1	-	38	X1.2	CHG0	-
14	X1.1	LSN3	-	39	X1.0	LSP3	-
15	X0.15	LSN2	CntB3/CntB5	40	X0.14	LSP2	CntB3/CntA5
16	X0.13	LSN1	CntB2/CntB4	41	X0.12	LSP1	CntA2/CntA4
17	X0.11	LSN0	CntB1	42	X0.10	LSP0	CntA1
18	X0.9-	MPGB-	CntB0-	43	X0.9+	MPGB+	CntB0+
19	X0.8-	MPGA-	CntA0-	44	X0.8+	MPGA+	CntA0+
20	X0.7	DOG3	-	45	X0.6	DOG2	-
21	X0.5	DOG1	-	46	X0.4	DOG0	-
22	X0.3-	Pg3-	Rst3-/Rst5-	47	X0.3+	Pg3+	Rst3+/Rst5+
23	X0.2-	Pg2-	Rst2-/Rst4-	48	X0.2+	Pg2+	Rst2+/Rst4+
24	X0.1-	Pg1-	Rst1-	49	X0.1+	Pg1+	Rst1+
25	X0.0-	Pg0-	Rst0-	50	X0.0+	Pg0+	Rst0+

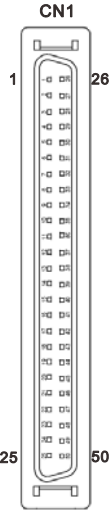

3

● AH20MC-5A

Pin	Terminal	Function		Pin	Terminal	Function	
		Pulse	Count			Pulse	Count
1	C3	-	COM3	19	Y0.11	-	Out3
2	C2	-	COM2	20	Y0.10	-	Out2
3	C1	-	COM1	21	Y0.9	-	Out1
4	C0	-	COM0	22	Y0.8	-	Out0
5	NC	-	-	23	NC	-	-
6	NC	-	-	24	NC	-	-
7	X0.3-	-	Rst3-/Rst5-	25	X0.3+	-	Rst3+/Rst5+
8	X0.15-	DOG3-	CntB3-/CntB5+	26	X0.15+	DOG3+	CntB3+/CntB5+
9	X0.14-	DOG2-	CntA3-/CntA5+	27	X0.14+	DOG2+	CntA3+/CntA5+
10	X0.2-	-	Rst2-/Rst4-	28	X0.2+	-	Rst2+/Rst4+
11	X0.13-	DOG1-	CntB2-/CntB4-	29	X0.13+	DOG1+	CntB2+/CntB4+
12	X0.12-	DOG0-	CntA2-/CntA4-	30	X0.12+	DOG0+	CntA2+/CntA4+
13	X0.1-	-	Rst1-	31	X0.1+	-	Rst1+
14	X0.11-	DOG5-	CntB1-	32	X0.11+	DOG5+	CntB1+
15	X0.10-	DOG4-	CntA1-	33	X0.10+	DOG4+	CntA1+
16	X0.0-	-	Rst0-	34	X0.0+	-	Rst0+
17	X0.9-	MPGB-	CntB0-	35	X0.9+	MPGB+	CntB0+
18	X0.8-	MPGA-	CntA0-	36	X0.8+	MPGA+	CntA0+

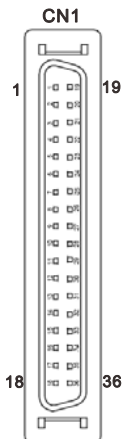

● External terminal module

1. External terminal module for AH04HC-5A: DVPAETB-IO16C

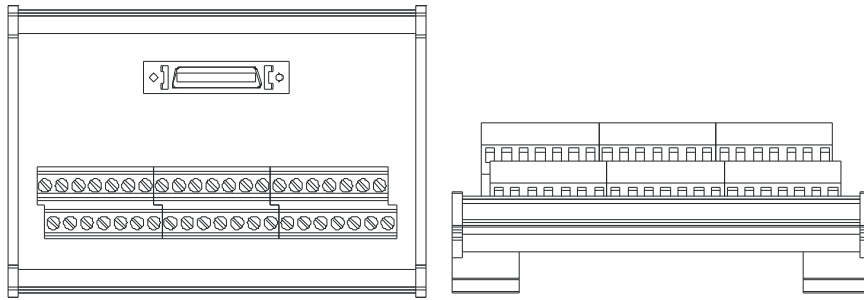

C3	C2	C1	C0	N/C	N/C	X0.3-	X0.15-	X0.14-	X0.2-	X0.13-	X0.12-	X0.1-	X0.11-	X0.10-	X0.0-	X0.9-	X0.8-	24G	24G	FE
Y0.11	Y0.10	Y0.9	Y0.8	N/C	N/C	X0.3+	X0.15+	X0.14+	X0.2+	X0.13+	X0.12+	X0.1+	X0.11+	X0.10+	X0.0+	X0.9+	X0.8+	N/C	24V	24V

2. External terminal module for AH10PM-5A: DVPAETB-IO24C

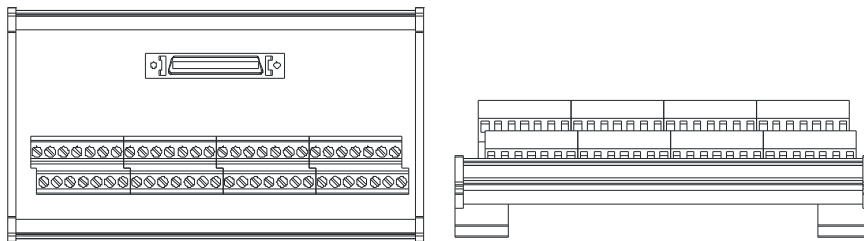

1 st from the upper left	C3	C2	C1	C0	N/C	Y0.7-	Y0.6-	Y0.5-	Y0.4-	Y0.3-	Y0.2-	Y0.1-	Y0.0-	N/C
15 th from the upper left	N/C	X0.15	X0.13	X0.11	X0.9	N/C	N/C	X0.3-	X0.2-	X0.1-	X0.0-	24G	24G	FE
1 st from the lower left	Y0.11	Y0.10	Y0.9	Y0.8	N/C	Y0.7+	Y0.6+	Y0.5+	Y0.4+	Y0.3+	Y0.2+	Y0.1+	Y0.0+	N/C
15 th from the lower left	S/S	X0.14	X0.12	X0.10	X0.8	N/C	N/C	X0.3+	X0.2+	X0.1+	X0.0+	N/C	24V	24V

3. External terminal module for AH15PM-5A: DVPAETB-IO34C

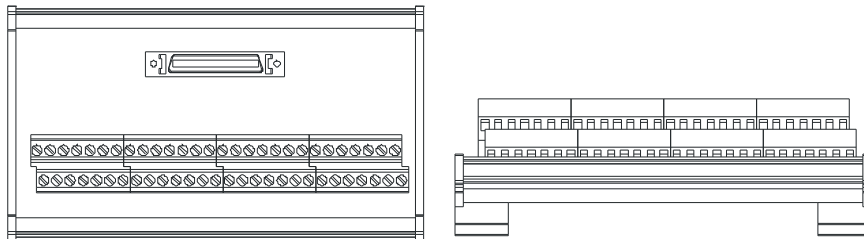

1 st from the upper left	Y0.11	Y0.9	COM	Y0.7-	Y0.6-	Y0.5-	Y0.4-	Y0.3-	Y0.2-	Y0.1-	Y0.0-	X1.5	X1.3	X1.1
15 th from the upper left	X0.15	X0.13	X0.11	X0.9-	X0.8-	X0.7	X0.5	X0.3-	X0.2-	X0.1-	X0.0-	24G	24G	FE
1 st from the lower left	Y0.10	Y0.8	Y0.7+	Y0.6+	Y0.5+	Y0.4+	Y0.3+	Y0.2+	Y0.1+	Y0.0+	S/S	X1.4	X1.2	X1.0
15 th from the lower left	X0.14	X0.12	X0.10	X0.9+	X0.8+	X0.6	X0.4	X0.3+	X0.2+	X0.1+	X0.0+	N/C	24V	24V

3

4. External terminal module for AH20MC-5A: DVPAETB-IO16C

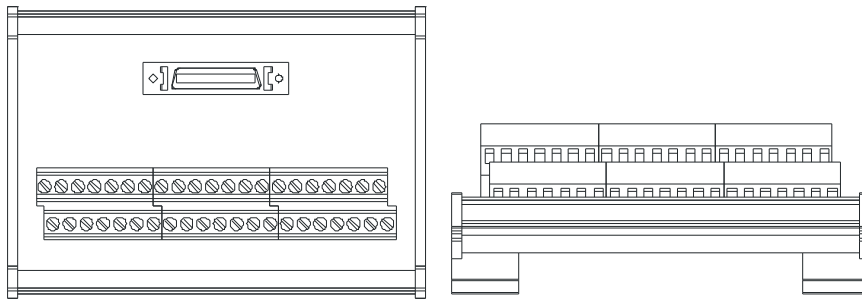

C3	C2	C1	C0	N/C	N/C	X0.3-	X0.15-	X0.14-	X0.2-	X0.13-	X0.12-	X0.1-	X0.11-	X0.10-	X0.0-	X0.9-	X0.8-	24G	24G	FE
Y0.11	Y0.10	Y0.9	Y0.8	N/C	N/C	X0.3+	X0.15+	X0.14+	X0.2+	X0.13+	X0.12+	X0.1+	X0.11+	X0.10+	X0.0+	X0.9+	X0.8+	N/C	24V	24V

3

3.10 Specifications for the Remote I/O Modules

3.10.1 General Specifications

- **AHRTU-DNET-5A**

Item	Specifications
Communication type	CAN
Electrical isolation	500 V DC
Connector type	Removable connector (5.08 mm)
Data type	I/O polled, and explicit
Communication speed	Standard mode: 125 kbps, 250 kbps, and 500 kbps Extended mode: 10 kbps, 20 kbps, 50 kbps, 125 kbps, 250 kbps, 500 kbps, 800 kbps, and 1 Mbps
Communication cable	Delta shielded twisted pair cables (Two communication cables, two power cables, and one shielded cable)

- **AHRTU-PFBS-5A**

Item	Specifications
Communication type	High-speed RS-485
Electrical isolation	500 V DC
Connector type	DB9 connector
Data type	Cyclic data exchange
Communication speed	9.6 kbps, 19.2 kbps, 45.45 kbps, 93.75 kbps, 187.5 kbps, 500 kbps, 1.5 Mbps, 3 Mbps, 6 Mbps, and 12 Mbps are supported.
Communication cable	Shielded twisted pair cable

3.10.2 Profiles

● AHRTU-DNET-5A

1. Profile

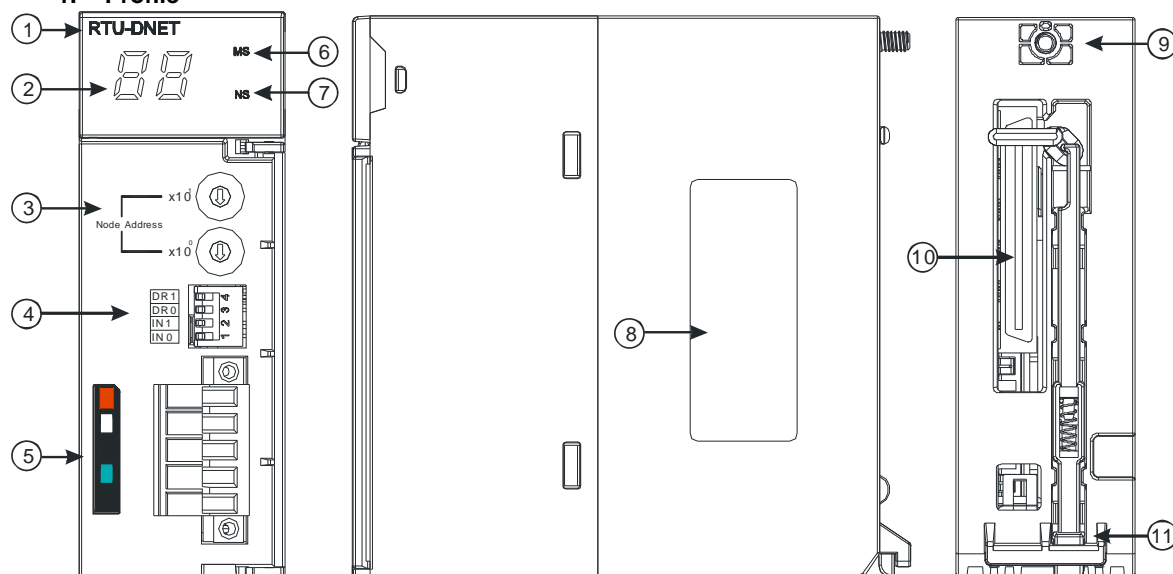

3

Number	Name	Description
1	Model name	Model name of the module
2	Seven-segment display	Display
3	Address knobs	Setting the address
4	Function switch	Setting the functions
5	DeviceNet connector	DeviceNet is used to interconnect control devices for data exchange.
6	MS LED indicator	Indicating the status of the module
7	NS LED indicator	Indicating the status of the network
8	Label	Nameplate
9	Set screw	Fixing the module
10	Connector	Connecting the module and a backplane
11	Projection	Fixing the module

2. Address knobs

It is used to set the node address of AHRTU-DNET-5A on a DeviceNet network. (Node addresses range from 0 to 63.)

Setting	Description	
0...63	Available nodes on a DeviceNet network	
64...99	Unavailable nodes on a DeviceNet network	

Example: If users want to set the communication address of AHRTU-DNET-5A to 26, they can turn the knob corresponding to $x10^1$ to 2, and turn the knob corresponding to $x10^0$ to 6.

Points for attention:

- When the power supply is cut off, the node address is set. After the setting of the node address is complete, AHRTU-DNET-5A can be supplied with power.
- If AHRTU-DNET-5A is running, changing the node address is unavailable.
- Please use a slotted screwdriver to turn the knobs with care, and do not scrape them.

3. Function switch

The function switch provides the following functions:

- Setting the working mode (IN 0)
- Setting the transmission speed of a DeviceNet network (DR 0–DR 1)

DR 1	DR 0	Transmission speed
OFF	OFF	125 kbps
OFF	ON	250 kbps
ON	OFF	500 kbps
ON	ON	Extended transmission speed

IN 1	Reserved	
IN 0	ON	Clearing the data in the internal storage in AHRTU-DNET-5A
	OFF	No action

Note:

- When the power supply is cut off, the functions are set. After the setting of the functions is complete, AHRTU-DNET-5A can be supplied with power.
- If AHRTU-DNET-5A is running, changing the functions is unavailable.
- Please use a slotted screwdriver to adjust the DIP switch with care, and do not scrape them.

4. DeviceNet connector

Pin	Signal	Color	Description
1	V+	Red	24 V DC
2	CAN_H	White	Signal (positive pole)
3	SHIELD	-	It is connected to a shielded cable.
4	CAN_L	Blue	Signal (negative pole)
5	V-	Black	0 V DC

● AHRTU-PFBS-5A

1. Profile

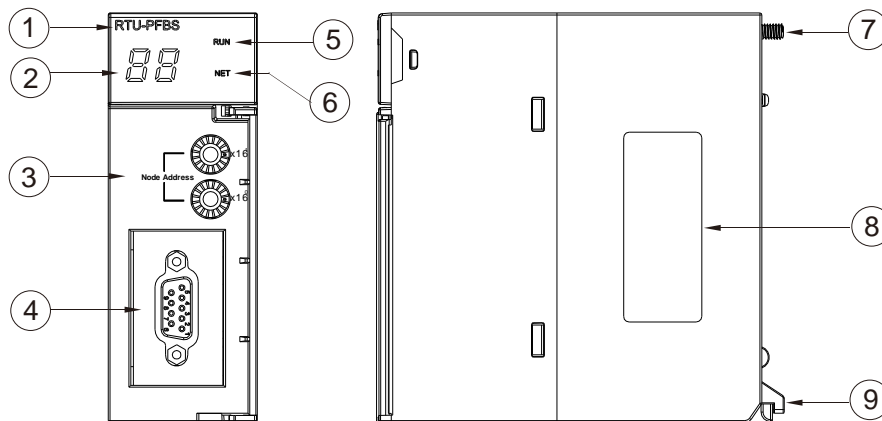

1. Model name	2. Seven-segment display	3. Address knobs
4. PROFIBUS-DP port	5. RUN LED indicator	6. NET LED indicator
7. Set screw	8. Label	9. Projection

3

2. Definitions of the pins in the PROFIBUS-DP port

PIN	PIN name	Description
1	--	N/C
2	--	N/C
3	RxD/TxD-P	Receiving/Sending data (P (B))
4	--	N/C
5	DGND	Data reference potential (C)
6	VP	Supply positive voltage
7	--	N/C
8	RxD/TxD-N	Receiving/Sending data (N (A))
9	--	N/C

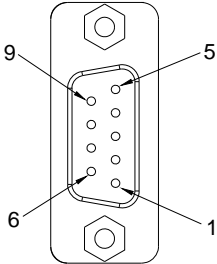

3. Setting a PROFIBUS node address by means of the address knobs

The address knobs of AHRTU-PFBS-5A are used for setting the node address of AHRTU-PFBS-5A on a PROFIBUS-DP network. There are two address knobs. They are a knob corresponding to $x16^0$, and a knob corresponding to $x16^1$. The range for one address knob is 0~F. The range for setting the node address is described below.

Address	Definition
H'1~H'7D	Valid PROFIBUS address
H'0 or H'7E~H'FF	Invalid PROFIBUS address

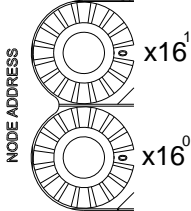

Example: If users need to set the node address of AHRTU-PFBS-5A to 26 (decimal value), they have to turn the knob corresponding to $x16^1$ to "1" and the knob corresponding to $x16^0$ to "A".
 26 (decimal value) = $1A$ (hexadecimal value) = $1 \times 16^1 + A \times 16^0$.

Points for attention:

- If users set the node address of AHRTU-PFBS-5A when AHRTU-PFBS-5A is not supplied with power, they have to power AHRTU-PFBS-5A after the node address of AHRTU-PFBS-5A is set.
- If users change the node address of AHRTU-PFBS-5A when AHRTU-PFBS-5A is powered, the change will not take effect immediately after the node address of AHRTU-PFBS-5A is changed, and it will take effect after the users cut off the power supplied to AHRTU-PFBS-5A and then power AHRTU-PFBS-5A again.
- To prevent the address knobs on AHRTU-PFBS-5A from being scratched, please carefully use a slotted screwdriver to rotate the address knobs on AHRTU-PFBS-5A.

3.10.3 Dimensions

● AHRTU-DNET-5A

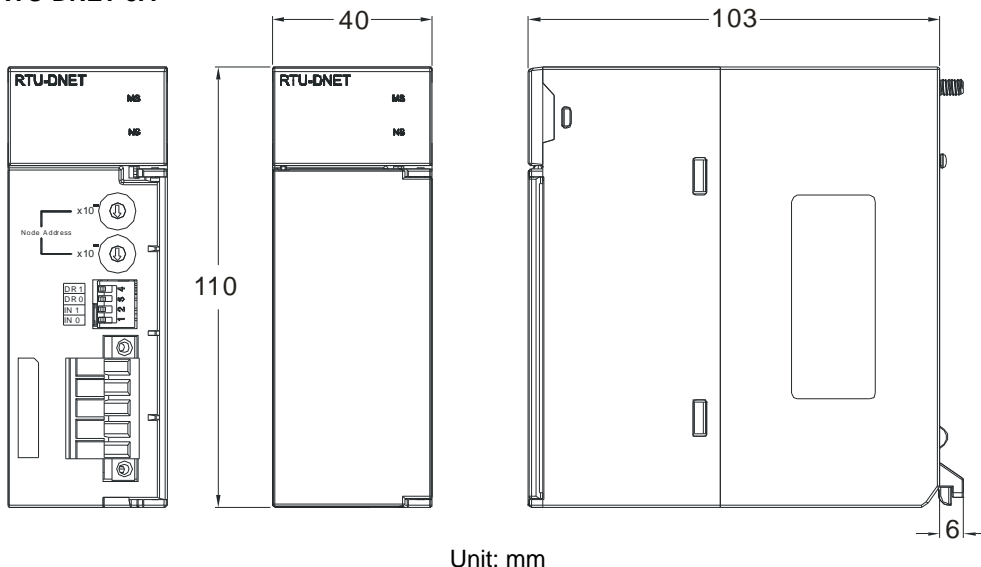

- AHRTU-PFBS-5A

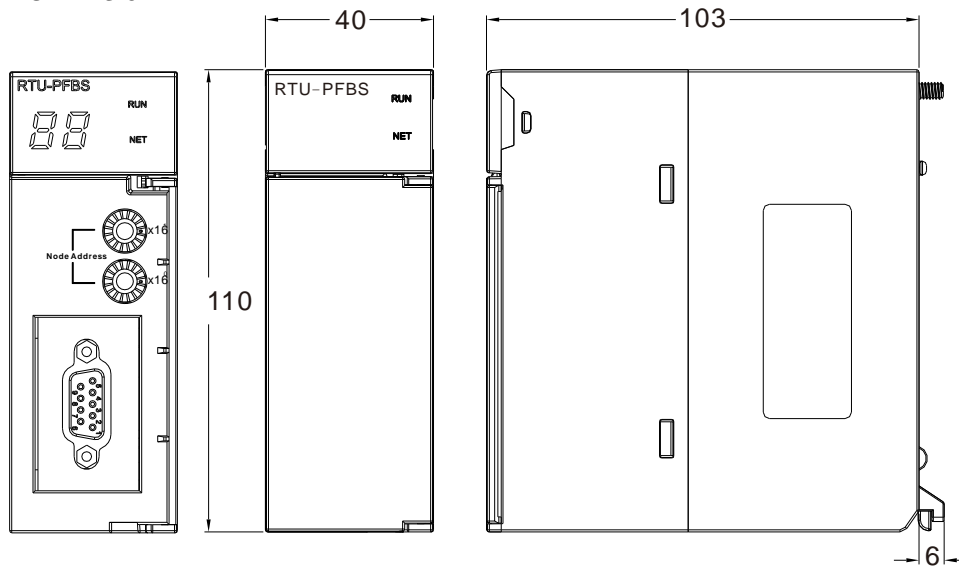

Unit: mm

3.11 Space Module and Extension Cables

3.11.1 General Specifications

- AHAADP01EF-5A/AHAADP02EF-5A

Item	Specifications
Connector type	155 Mbps 1*9 SC full-duplex optical fiber transceiver
Transmission interface	Optical fiber
Transmission speed	100 Mbps
Transmission distance	2 KM
Electric energy consumption	1.5 W
Insulation voltage	2,500 V DC

3.11.2 Profiles

- Space module AHASP01-5A

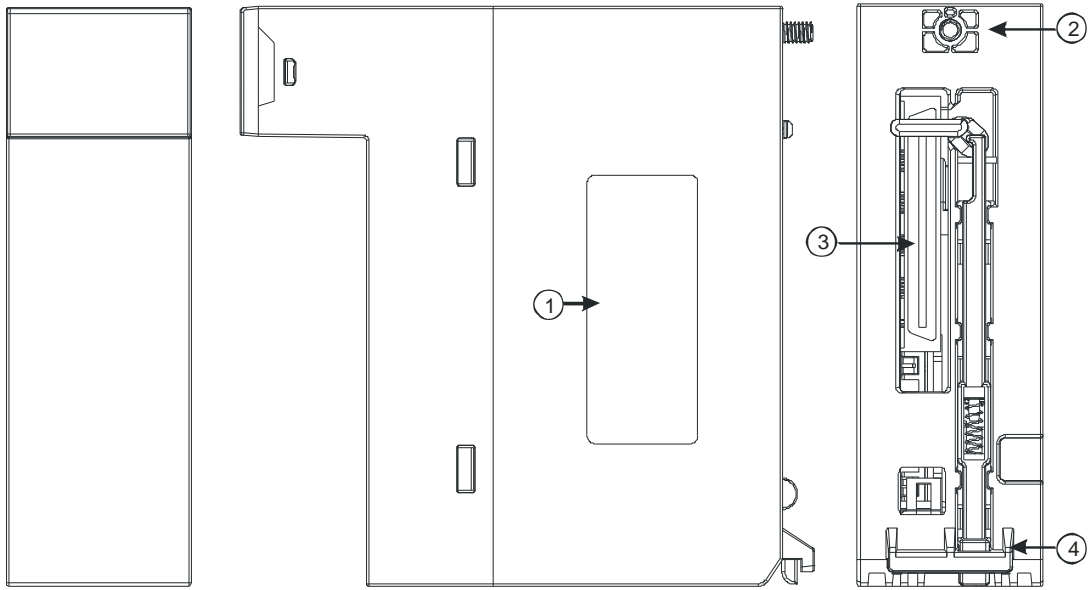

3

Number	Name	Description
1	Label	Nameplate
2	Set screw	Fixing the module
3	Connector	Connecting the module and a backplane
4	Projection	Fixing the module

- Extension cable

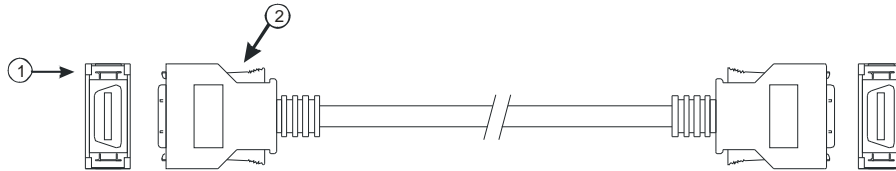

Number	Name	Description
1	Connector	Connecting backplanes 1. AHACAB06-5A 2. AHACAB10-5A 3. AHACAB15-5A 4. AHACAB30-5A
2	Clip	Fixing the connector

● AHAADP01EF-5A/AHAADP02EF-5A

AHAADP02EF-5A AHAADP01EF-5A

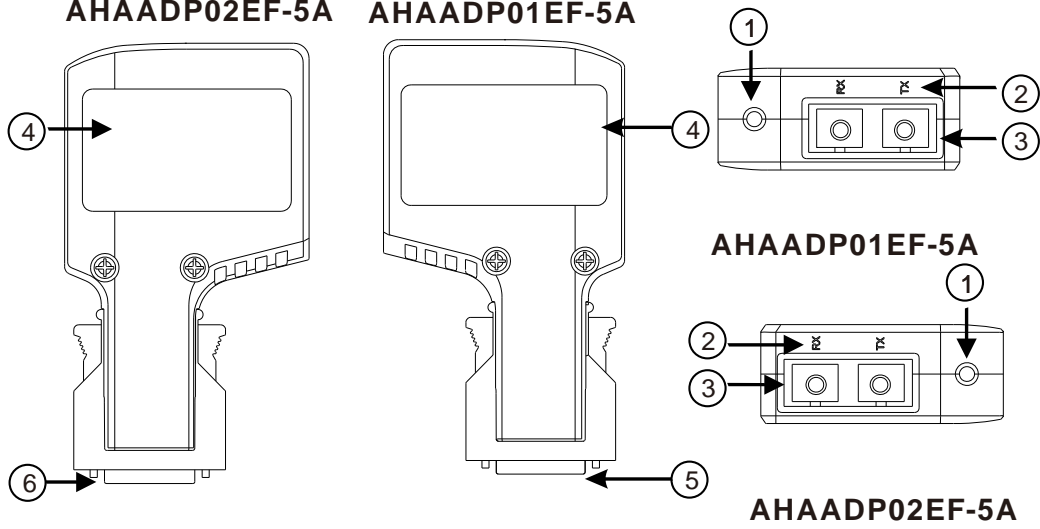

Number	Name
1	Connection/Communication LED indicator
2	Descriptions of the optical fiber ports (TX/RX)
3	Optical fiber ports
4	Label
5	Connector

3.11.3 Dimensions

● Space module AHASP01-5A

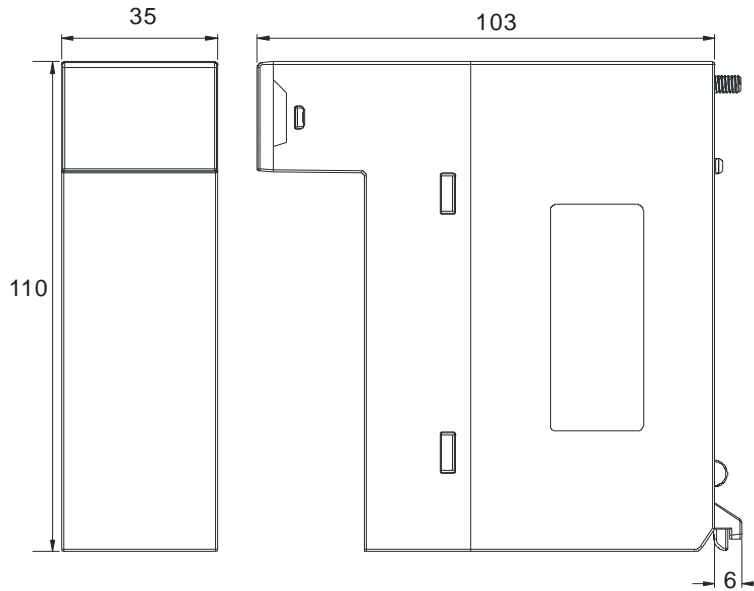

Unit: mm

● **Extension cable**

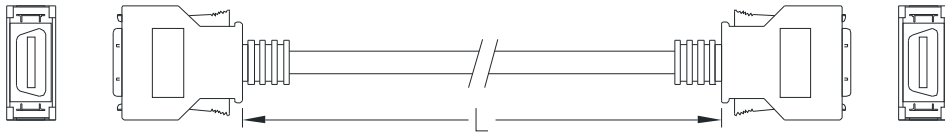

Extension cable	Length
AHACAB06-5A	0.6 m
AHACAB10-5A	1.0 m
AHACAB15-5A	1.5 m
AHACAB30-5A	3.0 m

● **AHAADP01EF-5A/AHAADP02EF-5A**

AHAADP02EF-5A

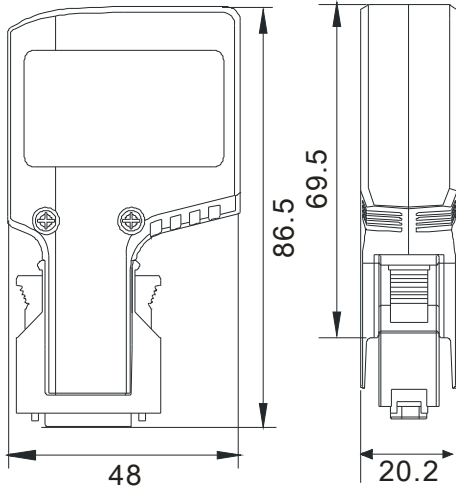

AHAADP01EF-5A

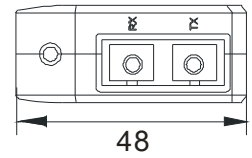
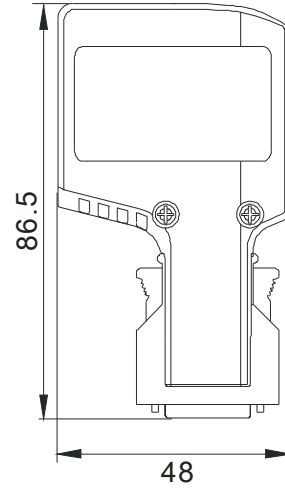

AHAADP01EF-5A

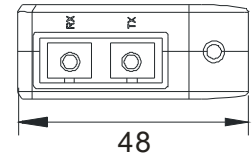

AHAADP02EF-5A

Unit: mm

MEMO

3

4

Chapter 4 Assigning Addresses

Table of Contents

4.1	Assigning I/O Addresses	4-2
4.2	Software-defined Addresses	4-3
4.2.1	Start Addresses for Digital Input/Output Modules	4-3
4.2.2	Start Addresses for Analog Input/Output Modules	4-4
4.2.3	Start Addresses for Temperature Measurement Modules.....	4-4
4.2.4	Start Addresses for Motion Control Modules.....	4-5
4.2.5	Start Addresses for Network Modules	4-6
4.3	User-defined Addresses	4-6
4.3.1	Start Addresses for Digital Input/Output Modules	4-6
4.3.2	Start Addresses for Analog Input/Output Modules	4-7
4.3.3	Start Addresses for Temperature Measurement Modules.....	4-8
4.3.4	Start Addresses for Motion Control Modules.....	4-8
4.3.5	Start Addresses for Network Modules	4-9

4.1 Assigning I/O Addresses

The assignment of input devices and that of output devices to an AH500 series input/output module installed on a local backplane are explained in this chapter.

HWCONFIG in ISPSOft

The following is the **HWCONFIG** window in ISPSOft. Please refer to chapter 8 in AH500 Operation Manual for more information related to the hardware configuration.

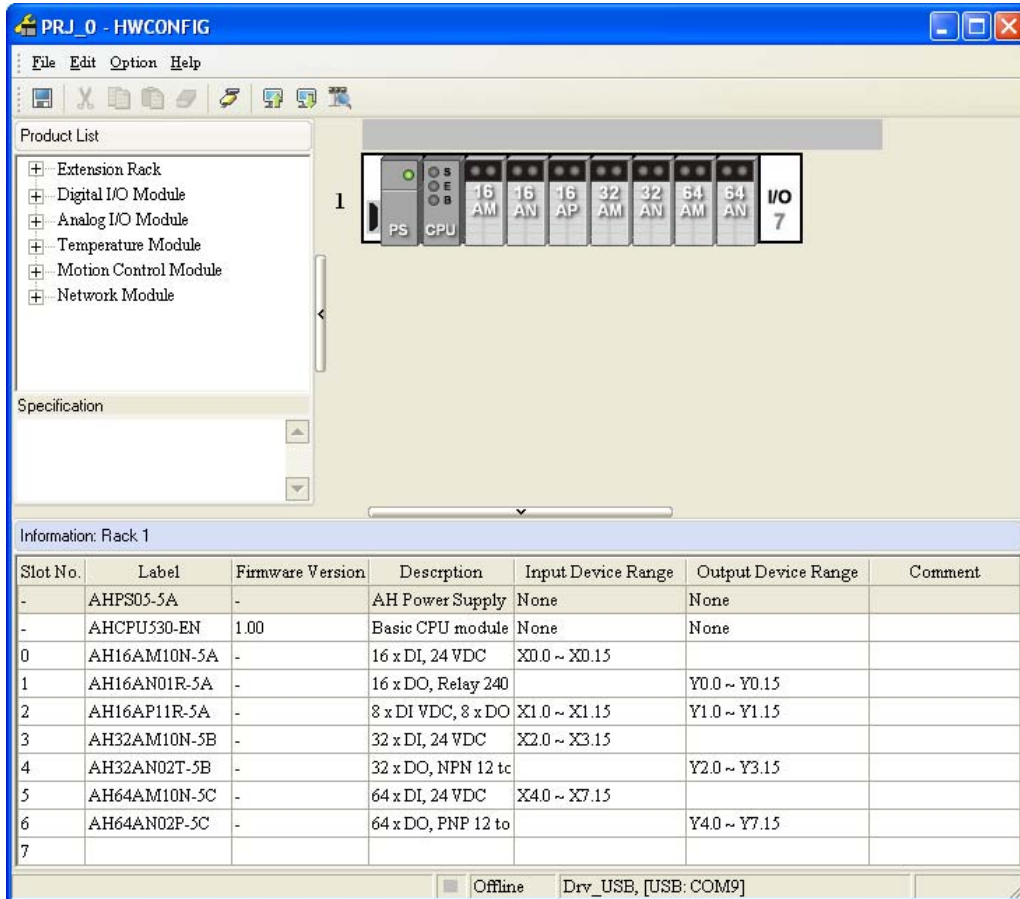

4

Software-defined address

Addresses are automatically assigned to an input/output module through HWCONFIG in ISPSOft. In other words, a start address is automatically assigned to an input/output module through HWCONFIG in ISPSOft.

User-defined address

Users can assign a start address to an input/output module through HWCONFIG in ISPSOft. The advantage is that a start address assigned to an input/output module is the address set by users. Besides, users can write a program easily.

4.2 Software-defined Addresses

4.2.1 Start Addresses for Digital Input/Output Modules

Input/Output devices are automatically assigned to a digital input/output module through HWCONFIG in ISPSOft according to the number of inputs/outputs which the digital input/output module has. The default start addresses are shown below.

- AH16AM10N-5A/AH16AM30N-5A: There are 16 inputs. The input device range occupies 16 bits. (Xn.0~Xn.15)
- AH16AN01R-5A/AH16AN01T-5A/AH16AN01P-5A/AH16AN01S-5A: There are 16 outputs. The output device range occupies 16 bits. (Yn.0~Yn.15)
- AH16AP11R-5A/AH16AP11T-5A/AH16AP11P-5A: There are 8 inputs, and 8 outputs. The input device range occupies 16 bits, and the output device range occupies 16 bits. (Xn.0~Xn.15, and Yn.0~Yn.15)
- AH16AR10N-5A: There are 16 inputs. The input device range occupies 16 bits. (Xn.0~Xn.15)
- AH32AM10N-5A/AH32AM10N-5B/AH32AM10N-5C: There are 32 inputs. The input device range occupies 32 bits. (Xn.0~Xn+1.15)
- AH32AN02T-5A/AH32AN02T-5B/AH32AN02T-5C/AH32AN02P-5A/AH32AN02P-5B/AH32AN02P-5C: There are 32 outputs. The output device range occupies 32 bits. (Yn.0~Yn+1.15)
- AH64AM10N-5C: There are 64 inputs. The input device range occupies 64 bits. (Xn.0~Xn+3.15)
- AH64AN02T-5C/AH64AN02P-5C: There are 64 outputs. The output device range occupies 64 bits. (Yn.0~Yn+3.15)

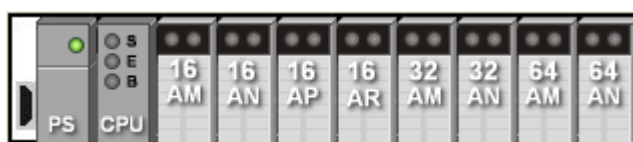

4

Information: Rack 1					
Slot No.	Label	Firmware Version	Description	Input Device Range	Output Device Range
-	AHPS05-5A	-	AH Power Supply Module	None	None
-	AHCPU530-EN	1.00	Basic CPU module building with	None	None
0	AH16AM10N-5A	-	16 x DI, 24 VDC	X0.0 ~ X0.15	
1	AH16AN01R-5A	-	16 x DO, Relay 240 VAC/24 VDC		Y0.0 ~ Y0.15
2	AH16AP11R-5A	-	8 x DI VDC, 8 x DO VAC/VDC	X1.0 ~ X1.15	Y1.0 ~ Y1.15
3	AH16AR10N-5A	1.00	16 x DI, 24 VDC	X2.0 ~ X2.15	
4	AH32AM10N-5A	-	32 x DI, 24 VDC	X3.0 ~ X4.15	
5	AH32AN02T-5A	-	32 x DO, NPN 12 to 24 VDC		Y2.0 ~ Y3.15
6	AH64AM10N-5C	-	64 x DI, 24 VDC	X5.0 ~ X8.15	
7	AH64AN02P-5C	-	64 x DO, PNP 12 to 24 VDC		Y4.0 ~ Y7.15

4.2.2 Start Addresses for Analog Input/Output Modules

Input/Output data registers are automatically assigned to an analog input/output module through HWCONFIG in ISPSOft according to the number of registers which is defined for the analog input/output module. A channel occupies two words.

- AH04AD-5A: There are 4 input channels. The input device range occupies 8 data registers.
- AH08AD-5B/AH08AD-5C: There are 8 input channels. The input device range occupies 16 data registers
- AH06XA-5A: There are 4 input channels, and 2 output channels. The input device range occupies 8 data registers, and the output device range occupies 4 data registers.
- AH04DA-5A: There are 4 output channels. The output device range occupies 8 data registers.
- AH08DA-5B/AH08DA-5C: There are 8 output channels. The output device range occupies 16 data registers.



4

Slot No.	Label	Firmware Version	Description	Input Device Range	Output Device Range	Comment
-	AHPS05-5A	-	AH Power Supply Module	None	None	
-	AHCPU530-EN	1.00	Basic CPU module building with Ethernet	None	None	
0	AH04AD-5A	1.00	4 x AI 16bit	D0 ~ D7		
1	AH08AD-5B	1.00	8 x AI 16bit	D8 ~ D23		
2	AH06XA-5A	1.00	4 x 16bit AI, 2 x 16bit AO	D24 ~ D31	D32 ~ D35	
3	AH04DA-5A	1.00	4 x AO 16bit		D36 ~ D43	
4	AH08DA-5B	1.00	4 x AO 16bit		D44 ~ D59	
5						
6						
7						

4.2.3 Start Addresses for Temperature Measurement Modules

Input data registers are automatically assigned to a temperature measurement module through HWCONFIG in ISPSOft according to the number of registers which is defined for the temperature measurement module. A channel occupies two words.

- AH04PT-5A: There are 4 input channels. The input device range occupies 8 data registers.
- AH08PTG-5A: There are 8 input channels. The input device range occupies 16 data registers.
- AH04TC-5A: There are 4 input channels. The input device range occupies 8 data registers.
- AH08TC-5A: There are 8 input channels. The input device range occupies 16 data registers



Slot No.	Label	Firmware Version	Description	Input Device Range	Output Device Range
-	AHPS05-5A	-	AH Power Supply Module	None	None
-	AHCPU530-EN	1.00	Basic CPU module building with	None	None
0	AH04PT-5A	1.00	4 x 3/4 wires RTD input 0.1 degree	D0 ~ D7	
1	AH08PTG-5A	1.00	8 x 3/4 wires RTD input 0.1 degree	D8 ~ D23	
2	AH04TC-5A	1.00	4 x 24 bit TC input 0.1 degree Ce	D24 ~ D31	
3	AH08TC-5A	1.00	8 x 24 bit TC input 0.1 degree Ce	D32 ~ D47	

4.2.4 Start Addresses for Motion Control Modules

Input/Output data registers are automatically assigned to a motion control module through HWCONFIG in ISPSOft according to the number of registers which is defined for the motion control module.

- AH02HC-5A: There are 2 input channels. The input device range occupies 14 data registers, and the output device range occupies 2 data registers.
- AH04HC-5A: There are 4 input channels. The input device range occupies 28 data registers, and the output device range occupies 4 data registers.
- AH05PM-5A: No input registers and no output registers are assigned to it. Please refer to AH5000 Motion Control Module Manual for more information about the parameter setting.
- AH10PM-5A: No input registers and no output registers are assigned to it. Please refer to AH5000 Motion Control Module Manual for more information about the parameter setting.
- AH15PM-5A: No input registers and no output registers are assigned to it. Please refer to AH5000 Motion Control Module Manual for more information about the parameter setting.
- AH20MC-5A: No input registers and no output registers are assigned to it. Please refer to AH5000 Motion Control Module Manual for more information about the parameter setting.



Information: Rack 1

Slot No.	Label	Firmware Version	Description	Input Device Range	Output Device Range
-	AHPS05-5A	-	AH Power Supply Modu	None	None
-	AHCPU530-EN	1.00	Basic CPU module buildi	None	None
0	AH02HC-5A	1.00	High speed counter, 2 ch	D0 ~ D13	D14 ~ D15
1	AH02HC-5A	1.00	High speed counter, 2 ch	D16 ~ D29	D30 ~ D31
2	AH05PM-5A	1.00	2-axis pulse-train MC	None	None
3	AH10PM-5A	1.00	6-axis pulse-train MC	None	None
4	AH15PM-5A	1.00	4-axis pulse-train MC	None	None
5	AH20MC-5A	1.00	12-axis DMCNET MC	None	None

4

4.2.5 Start Addresses for Network Modules

Input/Output data registers are automatically assigned to a motion control module through HWCONFIG in ISPSOft according to the number of registers which is defined for the motion control module.

- AH10EN-5A: The input device range occupies 20 data registers, and the output device range occupies 20 data registers.
- AH10SCM-5A: The input device range occupies 18 data registers.
- AH10DNET-5A: No input registers and no output registers are assigned to it.
- AH10PFBS-5A: No input registers and no output registers are assigned to it.
- AH10PFBM-5A: The input device range occupies 15 data registers.
- AH10COPM-5A: The input device range occupies 2 data registers.



4

Information: Rack 1

Slot No.	Label	Firmware Version	Description	Input Device Range	Output Device Range
-	AHPS05-5A	-	AH Power Supply Modu	None	None
-	AHCPU530-EN	1.00	Basic CPU module buildi	None	None
0	AH10EN-5A	1.00	Ethernet master module	D0 ~ D19	D20 ~ D39
1	AH10SCM-5A	1.00	Serial communication mo	D40 ~ D57	
2	AH10DNET-5A	1.00	DeviceNet scanner	None	None
3	AH10PFBS-5A	1.00	Profibus slave module	None	None
4	AH10PFBM-5A	1.00	Profibus master module	D1058 ~ D1072	
5	AH10COPM-5A	1.00	CANopen Communicatio	D1073 ~ D1074	

4.3 User-defined Addresses

4.3.1 Start Addresses for Digital Input/Output Modules

Users can assign input devices and output devices to a digital input/output module through HWCONFIG in ISPSOft. The input devices should be in the range of X0.0 to X511.15, and the output devices should be in the range of Y0.0 to Y511.15. Take AH16AP11R-5A for instance. The original input devices are X0.0~X0.15, and the original output devices are Y0.0~Y0.15. Users can change the input device range from X0.0~X0.15 to X10.0~X10.15, and change the output device range from Y0.0~Y0.15 to Y20.0~Y20.15.

- Default input/output device range: X0.0~X0.15, and Y0.0~Y0.15

Slot No.	Label	Firmware Version	Description	Input Device Range	Output Device Range	Comment
-	AHPS05-5A	-	AH Power Supply Module	None	None	
-	AHCPU530-EN	1.00	Basic CPU module building with Ethernet	None	None	
0	AH16AP11R-5A	-	8 x DI VDC, 8 x DO VAC/VDC	X0.0 ~ X0.15	Y0.0 ~ Y0.15	
1						
2						
3						
4						
5						
6						
7						

- User-defined input/output device range: X10.0~X10.15, and Y20.0~Y20.15

Slot No.	Label	Firmware Version	Description	Input Device Range	Output Device Range	Comment
-	AHPS05-5A	-	AH Power Supply Module	None	None	
-	AHCPU530-EN	1.00	Basic CPU module building with Ethernet	None	None	
0	AH16AP11R-5A	-	8 x DI VDC, 8 x DO VAC/VDC	X10.0 ~ X10.15	Y20.0 ~ Y20.15	
1						
2						
3						
4						
5						
6						
7						

4.3.2 Start Addresses for Analog Input/Output Modules

Users can assign input registers and output registers to an analog input/output module through HWCONFIG in ISPSOft. The input registers and the output registers should be in the range of D0 to D65535. Take AH06XA-5A for instance. The original input registers are D0~D7, and the original output registers are D8~D11. Users can change the input device range from D0~D7 to D50~D57, and change the output device range from D8~D11 to D100~D103.

- Default input/output device range: D0~D7, and D8~D11

Slot No.	Label	Firmware Version	Description	Input Device Range	Output Device Range	Comment
-	AHPS05-5A	-	AH Power Supply Module	None	None	
-	AHCPU530-EN	1.00	Basic CPU module building with Ethernet	None	None	
0	AH06XA-5A	1.00	4 x 16bit AI, 2 x 16bit AO	D0 ~ D7	D8 ~ D11	
1						
2						
3						
4						
5						
6						
7						

- User-defined input/output device range: D50~D57, and D100~D103

Slot No.	Label	Firmware Version	Description	Input Device Range	Output Device Range	Comment
-	AHPS05-5A	-	AH Power Supply Module	None	None	
-	AHCPU530-EN	1.00	Basic CPU module building with Ethernet	None	None	
0	AH06XA-5A	1.00	4 x 16bit AI, 2 x 16bit AO	D50 ~ D57	D100 ~ D103	
1						
2						
3						
4						
5						
6						
7						

4.3.3 Start Addresses for Temperature Measurement Modules

Users can assign input registers to a temperature measurement module through HWCONFIG in ISPSOft. The input registers should be in the range of D0 to D65535. Take AH08TC-5A for instance. The original input registers are D0~D15. Users can change the input device range from D0~D15 to D60~D75.

- Default input device range: D0~D15

Slot No.	Label	Firmware Versi...	Description	Input Device Range	Output Device Range	Comment
-	AHPS05-5A	-	AH Power Supply	None	None	
-	AHCPU530-EN	1.00	Basic CPU modul	None	None	
0	AH08TC-5A	1.00	8 x 24bit TC input	D0 ~ D15		
1						
2						
3						
4						
5						
6						
7						

4

- User-defined input device range: D60~D75

Slot No.	Label	Firmware Versi...	Description	Input Device Range	Output Device Range	Comment
-	AHPS05-5A	-	AH Power Supply	None	None	
-	AHCPU530-EN	1.00	Basic CPU modul	None	None	
0	AH08TC-5A	1.00	8 x 24bit TC input	D60 ~ D75		
1						
2						
3						
4						
5						
6						
7						

4.3.4 Start Addresses for Motion Control Modules

Users can assign input registers and output registers to a motion control module through HWCONFIG in ISPSOft. The input registers should be in the range of D0 to D65535, and the output registers should be in the range of D0 to D65535. Take AH04HC-5A for instance. The original input registers are D0~D27. Users can change the input device range from D0~D27 to D200~D227.

- Default input device range: D0~D27

Slot No.	Label	Firmware Version	Description	Input Device Range	Output Device Range	Comment
-	AHPS05-5A	-	AH Power Supply Module	None	None	
-	AHCPU530-EN	1.00	Basic CPU module building with Ethernet	None	None	
0	AH04HC-5A	1.00	High speed counter, 4 channels	D0 ~ D27	D28 ~ D31	
1						
2						
3						
4						

- User-defined input device range: D200~D227

Slot No.	Label	Firmware Version	Description	Input Device Range	Output Device Range	Comment
-	AHPS05-5A	-	AH Power Supply Module	None	None	
-	AHCPU530-EN	1.00	Basic CPU module building with Ethernet	None	None	
0	AH04HC-5A	1.00	High speed counter, 4 channels	D200 ~ D227	D28 ~ D31	
1						
2						
3						
4						

4.3.5 Start Addresses for Network Modules

Users can assign input registers and output registers to a network module through HWCONFIG in ISPSOft. The input registers should be in the range of D0 to D65535, and the output registers should be in the range of D0 to D65535. Take AH10EN-5A for instance. The original input registers are D0~D19. Users can change the input device range from D0~D19 to D150~D169.

- Default input device range: D0~D19

Slot No.	Label	Firmware Version	Description	Input Device Range	Output Device Range	Comment
-	AHPS05-5A	-	AH Power Supply Module	None	None	
-	AHCPU530-EN	1.00	Basic CPU module building with Ethernet	None	None	
0	AH10EN-5A	1.00	Ethernet master module	D0 ~ D19	D20 ~ D39	
1						
2						
3						
4						

- User-defined input device range: D150~D169

Slot No.	Label	Firmware Version	Description	Input Device Range	Output Device Range	Comment
-	AHPS05-5A	-	AH Power Supply Module	None	None	
-	AHCPU530-EN	1.00	Basic CPU module building with Ethernet	None	None	
0	AH10EN-5A	1.00	Ethernet master module	D150 ~ D169	D20 ~ D39	
1						
2						
3						
4						

4

MEMO

4

5

Chapter 5 Wiring



Table of Contents

5.1	Wiring	5-3
5.2	Connecting Power Cables.....	5-4
5.2.1	Precautions	5-4
5.2.2	Ground	5-5
5.2.3	Wiring Power Supply Modules.....	5-6
5.2.4	Power Consumption	5-8
5.3	Wiring CPU Modules	5-10
5.4	Wiring Digital Input/Output Modules.....	5-11
5.4.1	Wiring AH16AM10N-5A.....	5-11
5.4.2	Wiring AH16AM30N-5A.....	5-12
5.4.3	Wiring AH16AR10N-5A	5-13
5.4.4	Wiring AH16AN01S-5A	5-14
5.4.5	Wiring AH16AN01R-5A	5-15
5.4.6	Wiring AH16AN01T-5A.....	5-16
5.4.7	Wiring AH16AN01P-5A	5-17
5.4.8	Wiring AH16AP11R-5A	5-18
5.4.9	Wiring AH16AP11T-5A.....	5-19
5.4.10	Wiring AH16AP11P-5A	5-20
5.4.11	Wiring AH32AM10N-5A.....	5-21
5.4.12	Wiring AH32AM10N-5B.....	5-22
5.4.13	Wiring AH32AM10N-5C.....	5-23
5.4.14	Wiring AH32AN02T-5A.....	5-24
5.4.15	Wiring AH32AN02T-5B.....	5-25
5.4.16	Wiring AH32AN02T-5C	5-26
5.4.17	Wiring AH32AN02P-5A	5-28
5.4.18	Wiring AH32AN02P-5B	5-29
5.4.19	Wiring AH32AN02P-5C	5-30
5.4.20	Wiring AH64AM10N-5C.....	5-32
5.4.21	Wiring AH64AN02T-5C	5-33
5.4.22	Wiring AH64AN02P-5C	5-34
5.5	Wiring Digital Input/Output Terminals	5-35
5.5.1	Wiring Digital Input Terminals.....	5-35
5.5.1.1	Sinking and Sourcing.....	5-35
5.5.1.2	Relay Type.....	5-36
5.5.1.3	Open-collector Input Type	5-36
5.5.1.4	Two-wire Proximity Switch.....	5-37
5.5.1.5	Three-wire Switch.....	5-37
5.5.1.6	Optoelectronic Switch.....	5-38
5.5.1.7	Voltage Input (120~240 V AC).....	5-38
5.5.2	Wiring Digital Output Terminals.....	5-39
5.5.2.1	Output Circuits.....	5-39
5.5.2.2	Relay Output Circuit	5-40
5.5.2.3	Transistor Output Circuit.....	5-42
5.5.2.4	TRIAC Output Circuit.....	5-44
5.6	Wiring Analog Input/Output Modules.....	5-45
5.6.1	Wiring AH04AD-5A.....	5-45
5.6.2	Wiring AH08AD-5B.....	5-46
5.6.3	Wiring AH08AD-5C.....	5-46
5.6.4	Wiring AH04DA-5A.....	5-47

5.6.5	Wiring AH08DA-5B.....	5-48
5.6.6	Wiring AH08DA-5C	5-49
5.6.7	Wiring AH06XA-5A.....	5-50
5.7	Wiring Temperature Measurement Modules	5-51
5.7.1	Wiring AH04PT-5A.....	5-51
5.7.2	Wiring AH08PTG-5A	5-52
5.7.3	Wiring AH04TC-5A.....	5-53
5.7.4	Wiring AH08TC-5A.....	5-53
5.8	Wiring Network Modules	5-53
5.8.1	Wiring AH10DNET-5A.....	5-53
5.8.1.1	DeviceNet Connector	5-53
5.8.1.2	Connecting a Cable to the DeviceNet Connector.....	5-54
5.8.1.3	Installing the DeviceNet Connector	5-54
5.8.2	Wiring AH10EN-5A.....	5-55
5.8.3	Wiring AH10SCM-5A.....	5-55
5.8.4	Wiring AH10PFBM-5A/AH10PFBS-5A	5-55
5.8.4.1	Connecting the PROFIBUS-DP Connector	5-55
5.8.4.2	Definitions of the Pins in the PROFIBUS-DP Port.....	5-56
5.8.4.3	Setting a PROFIBUS Node Address by the Knobs	5-56
5.8.5	Wiring AH10COPM-5A	5-57
5.8.5.1	CANopen Communication Connector	5-57
5.8.5.2	Address Knobs	5-57
5.8.5.3	Function Switch	5-58
5.9	Wiring Remote I/O Modules	5-58
5.9.1	Wiring AHRTU-DNET-5A	5-58
5.9.1.1	DeviceNet Connector	5-58
5.9.1.2	Connecting a Cable to the DeviceNet Connector.....	5-58
5.9.1.3	Installing the DeviceNet Connector	5-59
5.9.2	Wiring AHRTU-PFBS-5A.....	5-60
5.9.2.1	Connecting the PROFIBUS-DP Connector	5-60
5.9.2.2	Definitions of the Pins in the PROFIBUS-DP Port.....	5-60
5.9.2.3	Setting a PROFIBUS Node Address by the Knobs	5-60
5.9.3	Wiring AHAADP01EF-5A/AHAADP02EF-5A	5-61
5.9.3.1	Connecting 100BASE-FX Fibers	5-61
5.9.3.2	Specifications for Cables	5-61
5.9.3.3	Installing AHAADP01EF-5A/AHAADP02EF-5A on a Backplane	5-61
5.10	Wiring Motion Control Modules	5-62
5.10.1	Specifications for Motion Control Modules	5-62
5.10.2	I/O Extension Cables and External Terminal Modules	5-73
5.10.3	Wiring AH02HC-5A and AH04HC-5A.....	5-75
5.10.3.1	External Wiring	5-77
5.10.3.2	Wiring the Differential Input Terminals	5-78
5.10.3.3	Transistor Output Circuit.....	5-79
5.10.4	Wiring AH05PM-5A, AH10PM-5A, and AH15PM-5A	5-80
5.10.4.1	Wiring Input Terminals	5-83
5.10.4.2	Wiring the Output Terminals	5-84
5.10.4.3	Wiring AH10PM-5A and an Inferior Servo Drive	5-87
5.10.5	Wiring AH20MC-5A	5-92
5.10.5.1	Wiring the Differential Input Terminals	5-93
5.10.5.2	Transistor Output Circuit.....	5-93

5.1 Wiring

● Points for attention

	<ul style="list-style-type: none"> ● Before installing or wiring a module, users need to make sure that the external power supply is turned off. If the power supply is not turned off, users may get an electric shock, or the product may be damaged. ● If the installation of the module or the wiring of the module is complete, users need to make sure that a terminal block cover is installed on the module before they turn on the power supply or operate the module. If the terminal block cover is not installed properly, users may get an electric shock, or the module may not operate normally.
	<ul style="list-style-type: none"> ● Be sure to connect the terminals FG and LG with protective grounding conductors. Otherwise, users may get an electric shock, or the module may not operate normally. ● To ensure that a PLC is wired correctly, users need to check the rated voltage of the product, and the arrangement of the terminals. If the PLC is connected to the power supply which does not conform to the rated voltage, or the product is not wired correctly, a fire accident will occur, or the product will be damaged. ● The external connections should be crimped or press-welded by specific tools, or soldered correctly. The improper connections will result in a short circuit, a fire accident, or erroneous operation. ● Tighten the terminal screws with the specified torque. If the terminal screws are loose, a short circuit, a fire accident, or erroneous operation will occur. Tightening the terminal screws too far, may cause damage to the terminal screws and the module, resulting in a short circuit or a malfunction. ● Make sure that there are no foreign substances such as iron filings or wiring debris inside the module. These foreign substances may result in a fire accident, damage, or erroneous operation.

5

● Wiring an I/O module

- (1) Terminals with insulation sleeves can not be arranged as a terminal block. It is recommended that the terminals be covered with insulation tubes.
- (2) Please use single-core cables or twin-core cables. The diameters of the cables used should be in the range of 12 AWG to 22 AWG. The torques applied to the screw terminals should be in the range of 5 kg-cm (4.3 lb-in) to 8 kg-cm (6.9 lb-in). Please use copper conducting wires. The temperature of the copper conducting wires should be 60/75°C.
- (3) Please keep the input cables, the output cables, and the power cable separate from one another.
- (4) If the main circuit and the power cable can not be separated from each other, please use a shielded cable, and ground it at the side of the I/O module. In some cases, the shielded cable is grounded at the opposite side.

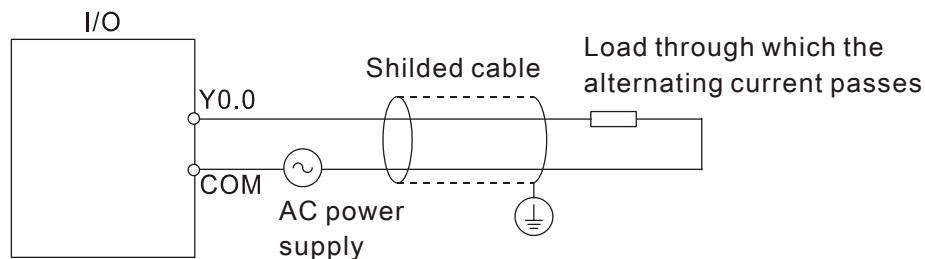

- (5) If users wire a module by means of piping, they need to ground the piping correctly.
- (6) Please keep 24 V DC input cables separate from 110 V AC input cables and 220 V DC input cables.
- (7) If the wiring length is more than 200 meters (686.67 inches), the leakage current will result from parasitic capacitance, and the system will break down.

● Grounding a cable

Please ground a cable according to the steps below.

- (1) Please ground a cable correctly.

- (2) The area of the cross-section of the cable which is grounded should be 2 mm^2 or larger than 2 mm^2 .
- (3) The ground point should be near the PLC. Ground the cable properly.

Note

- (1) The 110 V/220 V power cable and the 24 V DC power cable should be thick cables. (The area of the cross-section of the cable is 2 mm^2 , and the diameter of the cable is 14 AWG.) Be sure to twist the power cables at terminal screws. To prevent the short circuit which results from loose screws, users need to use solderless terminals with insulation sleeves.
- (2) If cables are connected to the terminals LG and FG, the cables need to be grounded. Do not connect LG and FG to any devices. If LG and FG are not grounded, the PLC will be susceptible to noise. Since LG have potential, users will get an electric shock if they touch metal parts.

5.2 Connecting Power Cables

5.2.1 Precautions

- **Connecting AC power cables**

- (1) Please separate the power cable of AHPS05-5A from the power cables for I/O devices and other devices. If there is much noise, connect an isolating transformer.

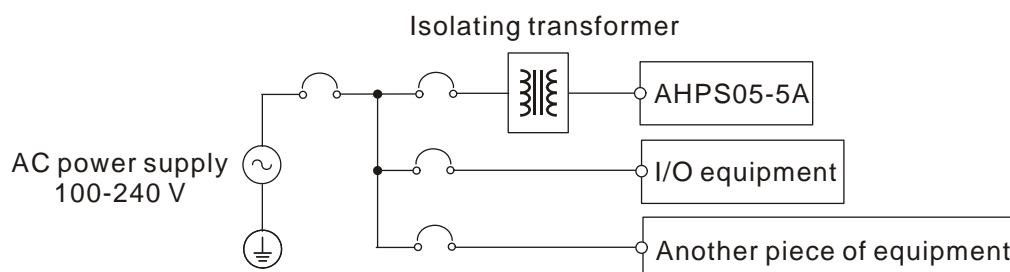

- (2) The 110 V AC cable, the 220 V AC cable, and the 24 V DC cable should be twisted, and connected to a module within a short distance.
- (3) Do not bundle 110 V AC cable, the 220 V AC cable, the 24 V DC cable, the (high-voltage high-current) main circuit, and the I/O signal cable together. Besides, it is recommended that the distance between adjacent cables should be more than 100 millimeters.
- (4) To prevent the surge resulting from lightning, please install a surge absorber in the way shown below.

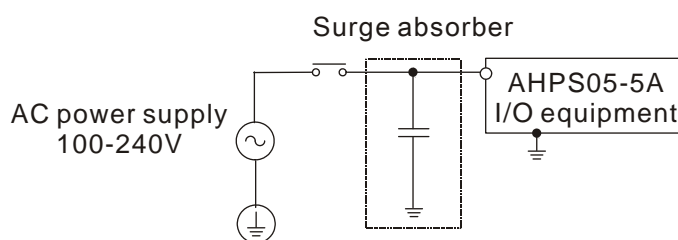
**Points for attention:**

1. The surge absorber and the PLC system should be grounded separately.
2. Please select the surge absorber whose working voltage is not less than the maximum allowable input voltage.

● **Connecting DC power cables**

- (1) AHPS15-5A is independently supplied with power by a DC power supply. Please separate the power cable of the DC power supply from the power cables for I/O devices and other devices. If there is much noise, connect an isolating transformer.

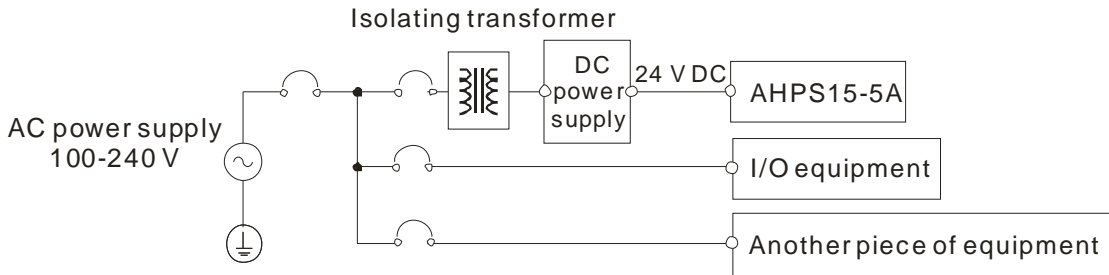

- (2) The 110 V AC cable, the 220 V AC cable, and the 24 V DC cable should be twisted, and connected to a module within a short distance.
- (3) Do not bundle 110 V AC cable, the 220 V AC cable, the 24 V DC cable, the (high-voltage high-current) main circuit, and the I/O signal cable together. Besides, it is recommended that the distance between adjacent cables should be more than 100 millimeters.
- (4) To prevent the surge resulting from lightning, please install a surge absorber in the way shown below.

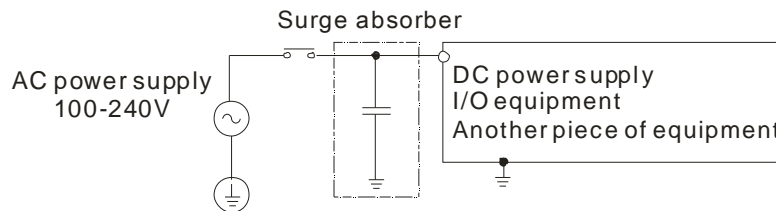

Points for attention:

1. The surge absorber and the PLC system should be grounded separately.
2. Please select the surge absorber whose working voltage is not less than the maximum allowable input voltage.

5.2.2 Ground

- The diameter of the ground should not be less than the diameters of the cables connected to the terminals L and N.
- If much equipment is used, please use single-point ground.

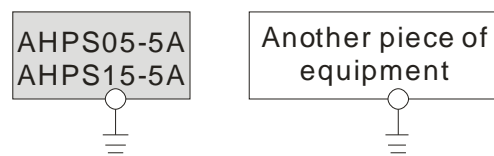

The single-point ground is better.

- If single-point ground can not be used, please use common-point ground.

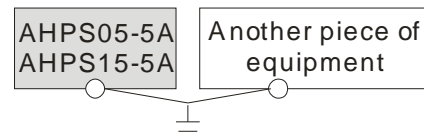

The common-point ground is permitted.

- Users can not ground equipment in the way shown on the right.

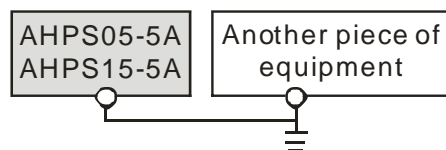

The equipment can not be grounded in this way.

5.2.3 Wiring Power Supply Modules

- Connecting an AC power cable

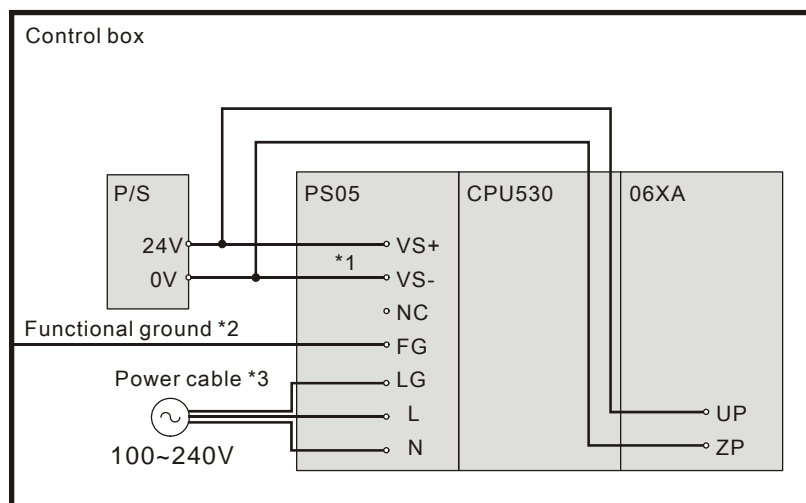

- *1. 24V on the external power supply is connected to VS+ and VS- on the power supply module. VS+ and VS- can be used to detect whether the voltage of the external power supply is stable.
- *2. FG on the power supply module is connected to the control box as the functional ground.
- *3. The live wire and the neutral wire in the AC power cable are connected to L and N on the power supply module respectively. To prevent the system from becoming abnormal, the ground in the AC power cable has to be connected to LG on the power supply module.

5

The power input of AHPS05-5A is the AC input. Users have to pay attention to the following points when they use AHPS05-5A.

- The alternating-current input voltage is in the range of 100 V AC to 240 V AC. Please connect the power supply to the terminals L and N. If the 110 V AC or the 220 V AC power supply is connected to the input terminals VS+ and VS-, the PLC will be damaged.
- In order to ensure that the external power supply stably provides 24 V DC power, the external power supply can be connected to VS+ and VS-. If the PLC detects that the voltage of the external power supply is lower than the working voltage, users can write a protective program.
- The length of the cable connecting with the ground should be more than 1.6 millimeters.
- If the power cut lasts for less than 10 milliseconds, the PLC keeps running without being affected. If the power cut lasts for long, or if the voltage of the power supply decreases, the PLC stops running, and there is no output. When the power supply returns to normal, the PLC resumes. (Users have to notice that there are latched auxiliary relays and registers in the PLC when they write the program.)
- Please use single-core cables or multicore cables. The diameters of the cables used should be in the range of 12 AWG to 22 AWG. The torque applied to the terminal screws should be 9.50 kg-cm (8.25 lb-in). Please use copper conducting wires. The temperature of the copper conductive cables should be 60/75°C.

- Safety wiring: The PLC controls many devices, and the activity of any device affects the activity of other devices. If any device breaks down, the whole automatic control system goes out of control, and the danger occurs. The protection circuit is shown below.

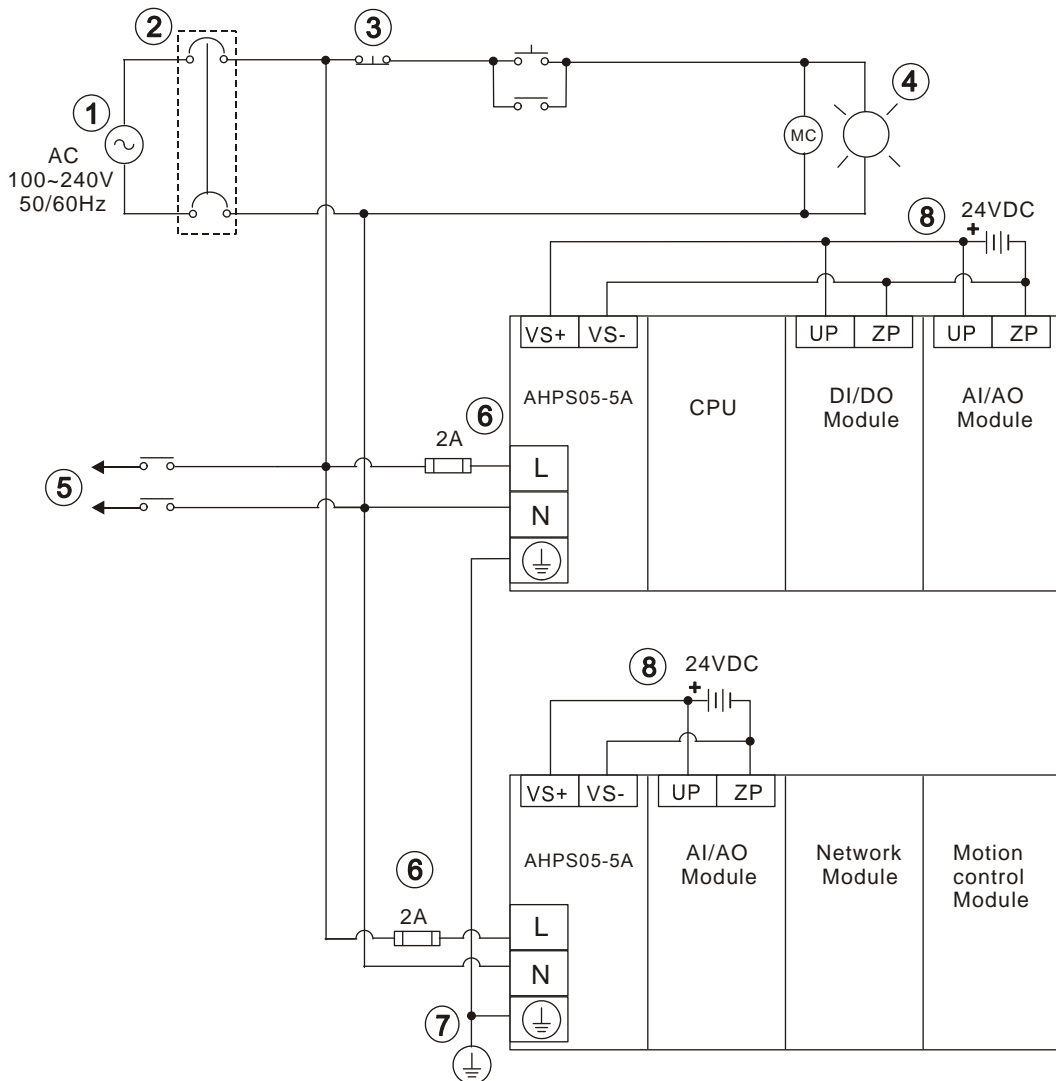

5

①	Alternating-current power supply: 100~240 V AC, and 50/60 Hz
②	Circuit breaker
③	Emergency stop: The emergency stop button can be used to cut off the power when an emergency occurs.
④	Power indicator
⑤	Load through which the alternating current passes
⑥	2 A fuse
⑦	The ground impedance is less than 100 Ω.
⑧	Direct-current power supply: 24 V DC

● Connecting a DC power cable

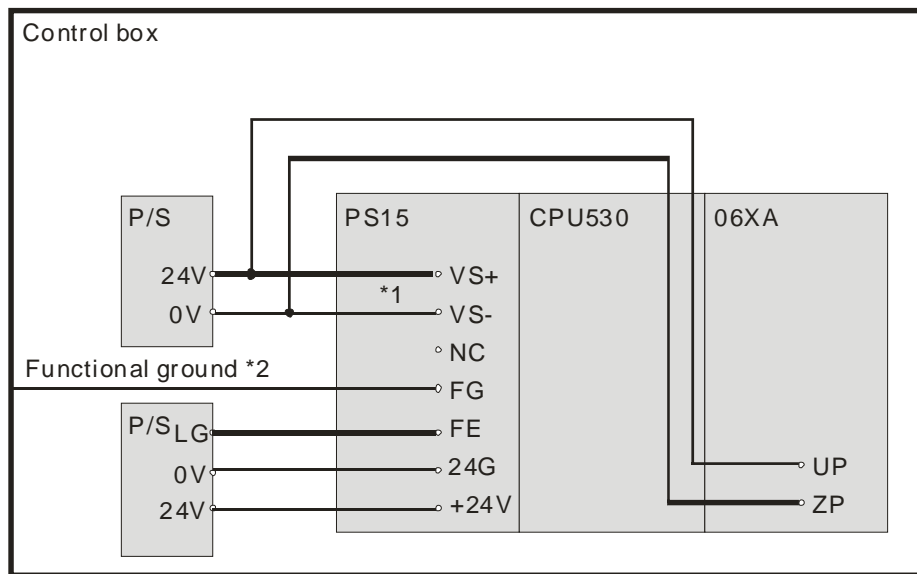

*1. 24V on the external power supply is connected to VS+ and VS- on the power supply module. VS+ and VS- can be used to detect whether the voltage of the external power supply is stable.

*2. FG on the power supply module is connected to the control box as the functional ground.

*3. +24V and 24G on the power supply module are connected to 24V and 0V on the DC power supply. To prevent the system from becoming abnormal, the ground of the DC power supply has to be connected to FE on the power supply module.

5

The power input of AHPS15-5A is the DC input. Users have to pay attention to the following points when they use AHPS15-5A.

- In order to ensure that the external power supply stably provides 24 V DC power, the external power supply can be connected to VS+ and VS-. If the PLC detects that the voltage of the external power supply is lower than the working voltage, users can write a protective program.
- The length of the cable connecting with the ground should be more than 1.6 millimeters.
- If the power cut lasts for less than 10 milliseconds, the PLC keeps running without being affected. If the power cut lasts for long, or if the voltage of the power supply decreases, the PLC stops running, and there is no output. When the power supply returns to normal, the PLC resumes. (Users have to notice that there are latched auxiliary relays and registers in the PLC when they write the program.)
- Please use single-core cables or multicore cables. The diameters of the cables used should be in the range of 12 AWG to 22 AWG. The torque applied to the terminal screws should be 9.50 kg-cm (8.25 lb-in). Please use copper conducting wires. The temperature of the copper conductive cables should be 60/75°C.

5.2.4 Power Consumption

Classification	Model name	Internal power consumption	External power consumption
CPU module	AHCPU500-RS2	2 W	-
	AHCPU510-RS2	2 W	-
	AHCPU520-RS2	2 W	-
	AHCPU530-RS2	2 W	-
	AHCPU500-EN	2 W	-
	AHCPU510-EN	2 W	-
	AHCPU520-EN	2 W	-
	AHCPU530-EN	2 W	-
Main backplane	AHBP04M1-5A	10 mW	-

Classification	Model name	Internal power consumption	External power consumption
Main backplane	AHBP06M1-5A	10 mW	-
	AHBP08M1-5A	10 mW	-
	AHBP12M1-5A	10 mW	-
Extension backplane	AHBP06E1-5A	1.41 W	-
	AHBP08E1-5A	1.41 W	-
Digital I/O module	AH16AM10N-5A	0.1 W	1.9 W
	AH16AM30N-5A	0.1 W	-
	AH16AN01P-5A	0.2 W	0.4 W
	AH16AN01R-5A	2.1 W	-
	AH16AN01S-5A	0.6 W	-
	AH16AN01T-5A	0.2 W	0.4 W
	AH16AP11P-5A	0.2 W	0.2 W
	AH16AP11R-5A	1.1 W	-
	AH16AP11T-5A	0.2 W	0.2 W
	AH16AR10N-5A	0.5 W	-
	AH32AM10N-5A	0.2 W	3.8 W
	AH32AM10N-5B	0.2 W	3.8 W
	AH32AM10N-5C	0.2 W	3.8 W
	AH32AN02P-5A	0.4 W	0.8 W
	AH32AN02P-5B	0.4 W	0.8 W
	AH32AN02P-5C	0.4 W	0.8 W
	AH32AN02T-5A	0.4 W	0.8 W
	AH32AN02T-5B	0.4 W	0.8 W
	AH32AN02T-5C	0.4 W	0.8 W
Digital I/O module	AH64AM10N-5C	0.2 W	4.9 W
	AH64AN02P-5C	0.6 W	1.5 W
	AH64AN02T-5C	0.6 W	1.5 W
Analog I/O module	AH04AD-5A	0.35 W	1 W
	AH04DA-5A	0.34 W	2.6 W
	AH06XA-5A	0.34 W	1.4 W
	AH08AD-5B	1.9 W	-
	AH08DA-5B	0.25 W	2.2 W
	AH08AD-5C	1.6 W	-
	AH08DA-5C	0.25 W	3.7 W
Temperature measurement module	AH04PT-5A	2 W	-
	AH08PTG-5A	0.7 W	4 W
	AH04TC-5A	1.5 W	-
	AH08TC-5A	1.5 W	-
Motion control module	AH02HC-5A	2.4 W	-
	AH04HC-5A	2.4 W	-
	AH05PM-5A	2.7 W	-
	AH10PM-5A	2.7 W	-
	AH15PM-5A	2.7 W	-
	AH20MC-5A	3 W	-
Network module	AH10EN-5A	1.6 W	-
	AH10SCM-5A	1.2 W	-
	AH10DNET-5A	0.9 W	0.72 W
	AH10PFBS-5A	1 W	-
	AH10PFBM-5A	2 W	-
	AH10COPM-5A	0.8 W	-
Remote I/O module	AHRTU-DNET-5A	0.75 W	0.72 W
	AHRTU-PFBS-5A	2 W	-

5.3 Wiring CPU Modules

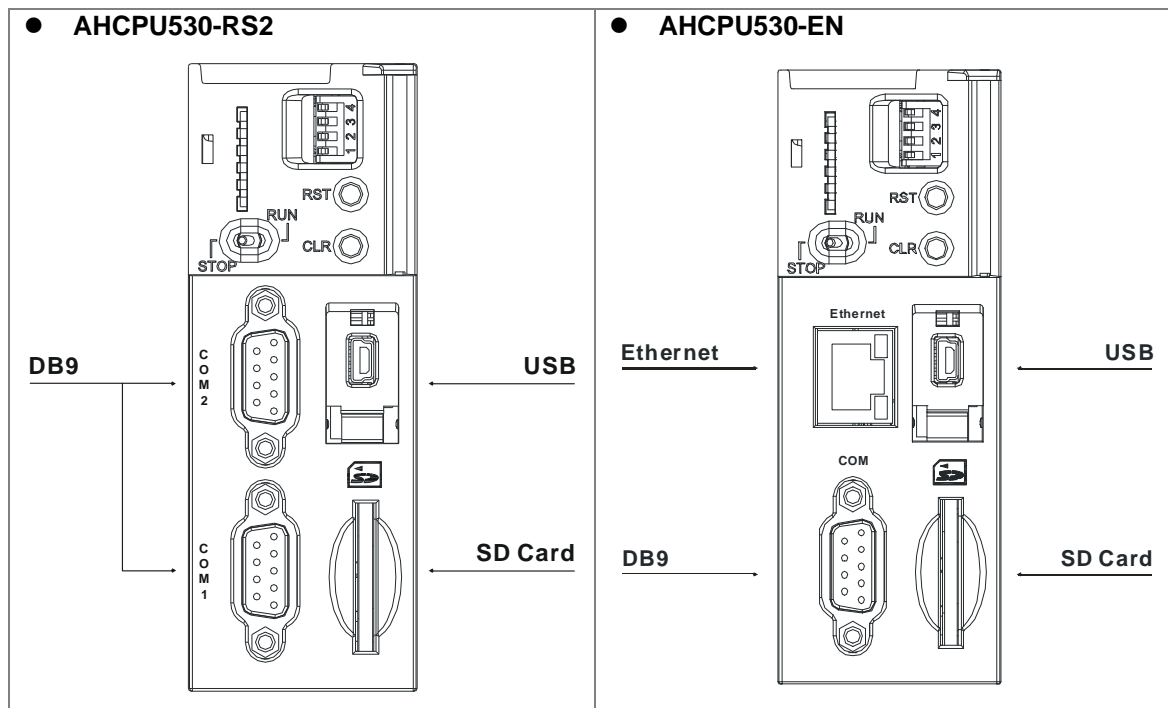

5

● DB9 connector

Pin	Function		
	RS485	RS422	RS232
1	D+	RX+	N/C
2	N/C	N/C	RX
3	N/C	N/C	TX
4	N/C	TX+	N/C
5	Ground	Ground	Ground
6	D-	RX-	N/C
7	N/C	N/C	N/C
8	N/C	N/C	N/C
9	N/C	TX-	N/C

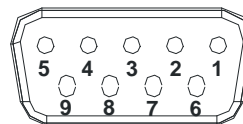

● USB port

Pin	Function
1	VBUS (4.4–5.25 V)
2	D-
3	D+
4	Ground
5	Ground

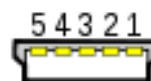

Mini-B

● Ethernet port

Pin	Signal	Description
1	TX+	Transmitting data (positive pole)
2	TX-	Transmitting data (negative pole)
3	RX+	Receiving data (positive pole)
4	--	N/C
5	--	N/C
6	RX-	Receiving data (negative pole)
7	--	N/C
8	--	N/C

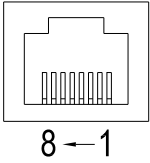

5.4 Wiring Digital Input/Output Modules

The wiring of digital input/output modules is illustrated simply in this section. The simplistic wiring diagrams below also illustrate how the power supplies are connected to S/S, UP, ZP and COM. If users want to get more information about the wiring of digital input/output terminals, they can refer to section 5.5 in this manual.

5.4.1 Wiring AH16AM10N-5A

Input form	Direct current (sinking or sourcing)
Input current	24 V DC, 5 mA

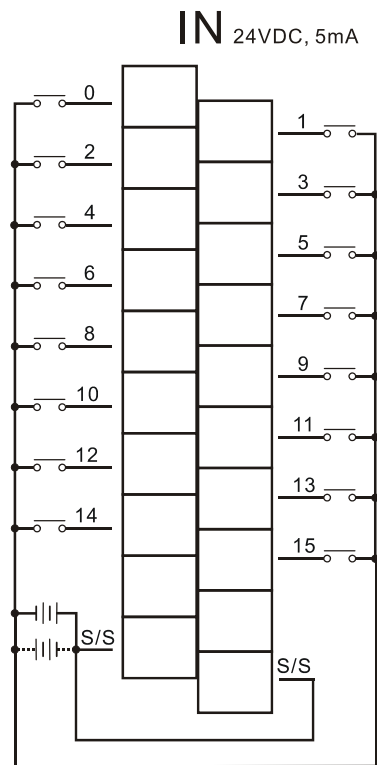
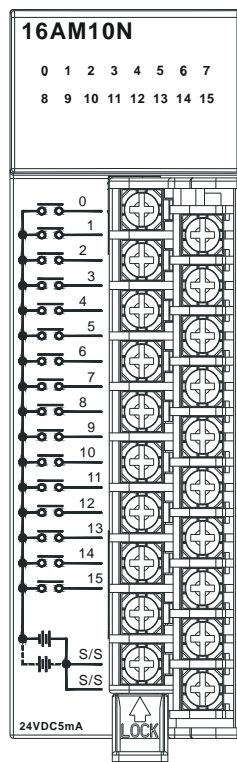

5.4.2 Wiring AH16AM30N-5A

Input form	Alternating current
Input current	120 V AC, 4.5 mA; 240 V AC, 9 mA

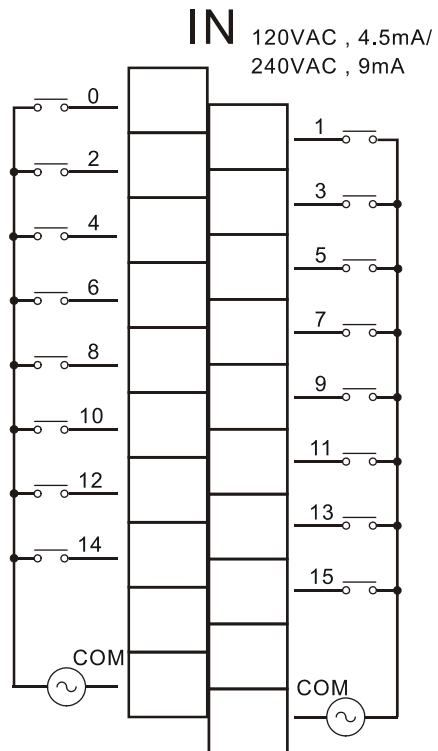
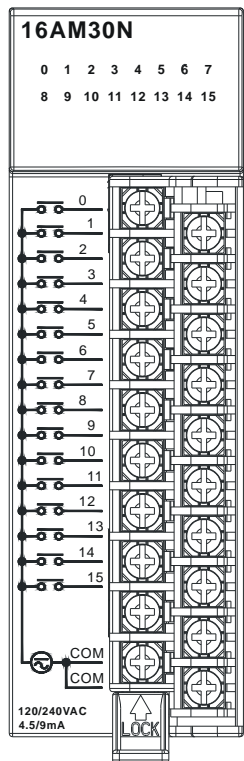

5

5.4.3 Wiring AH16AR10N-5A

Input form	Direct current (sinking or sourcing)
Input current	240 V DC, 5 mA

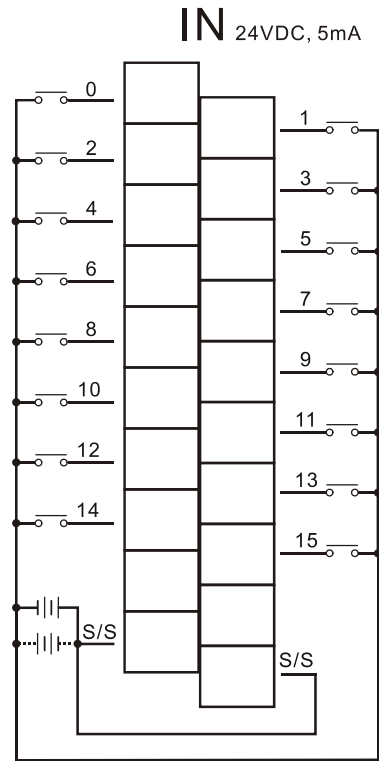
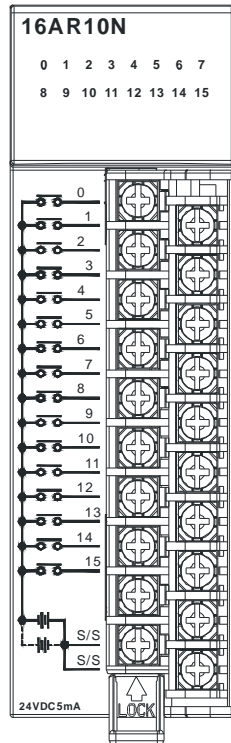

5

5.4.4 Wiring AH16AN01S-5A

Output type	TRIAC-S
Voltage specifications	120/240 V AC, 0.5 A

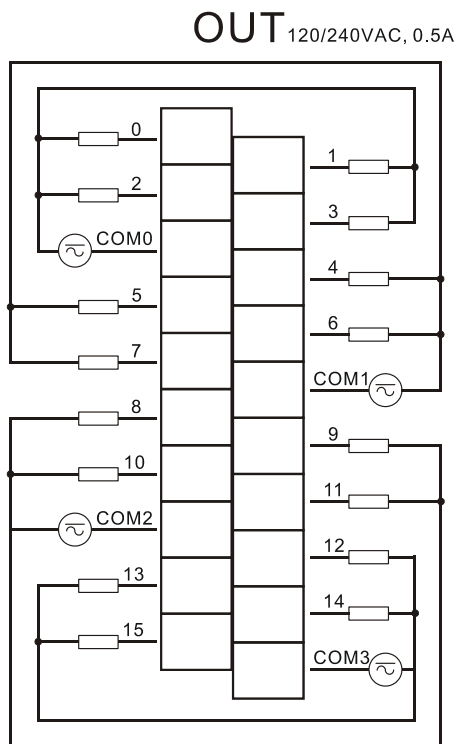
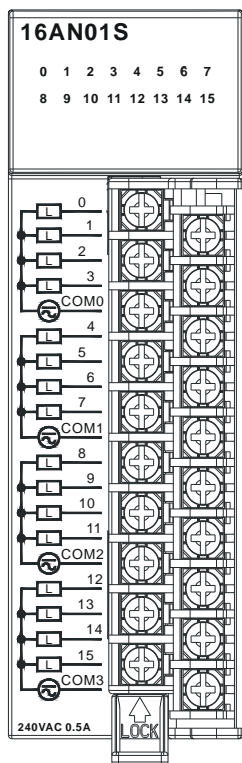

5

5.4.5 Wiring AH16AN01R-5A

Output type	Relay-R
Voltage specifications	24 V DC, 240 V AC, 2 A

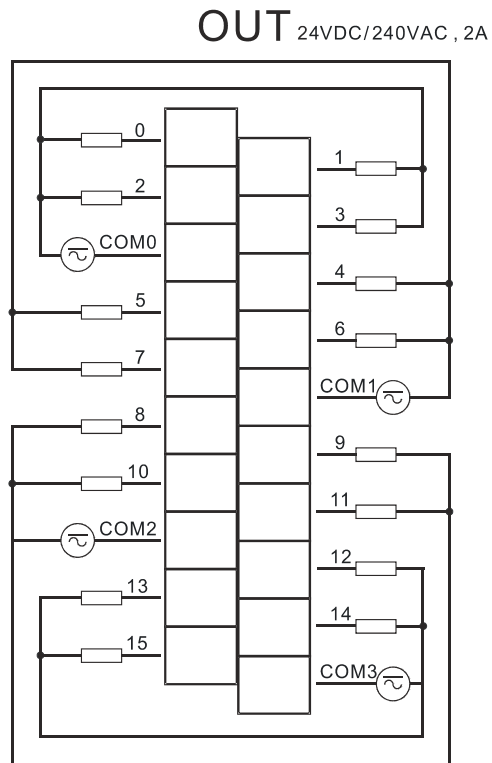
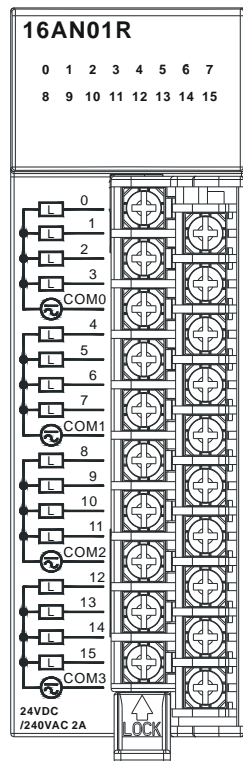

5

5.4.6 Wiring AH16AN01T-5A

Output type	Transistor-T (sinking)
Voltage specifications	12~24 V DC, 0.5 A

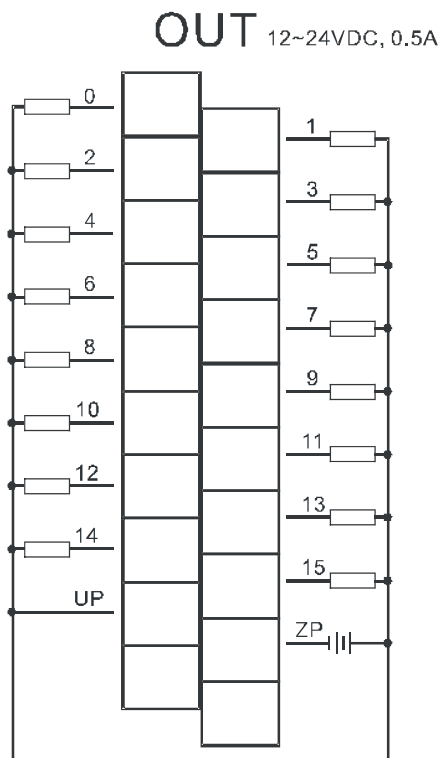
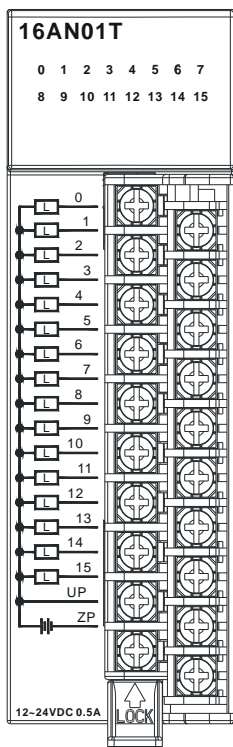

5

5.4.7 Wiring AH16AN01P-5A

Output type	Transistor-P (sourcing)
Voltage specifications	12~24 V DC, 0.5 A

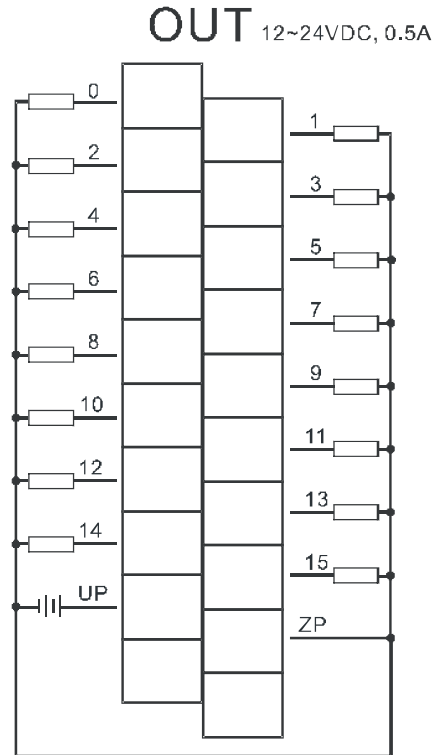
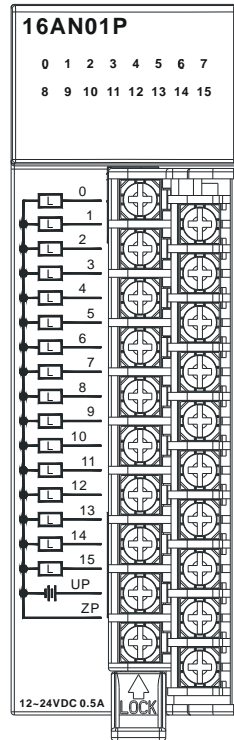

5

5.4.8 Wiring AH16AP11R-5A

Input form	Direct current (sinking or sourcing)
Input current	24 V DC, 5 mA
Output type	Relay-R
Voltage specifications	24 V DC, 240 V AC, 2 A

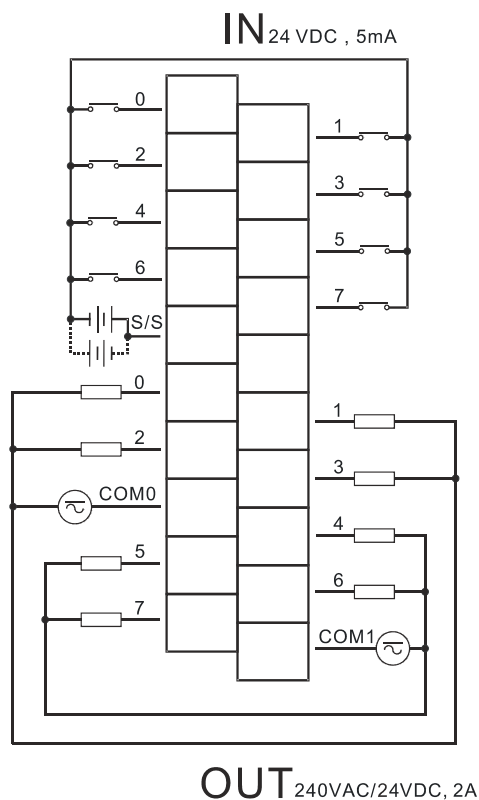
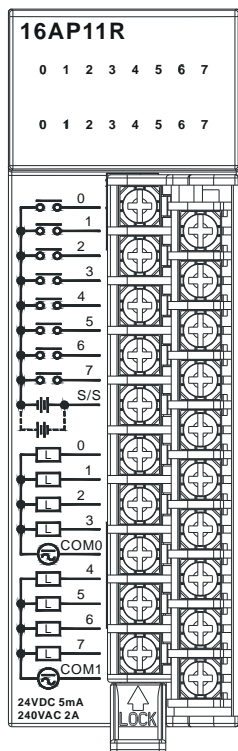

5

5.4.9 Wiring AH16AP11T-5A

Input form	Direct current (sinking or sourcing)
Input current	24 V DC, 5 mA
Output type	Transistor-T (sinking)
Voltage specifications	12~24 V DC, 0.5 A

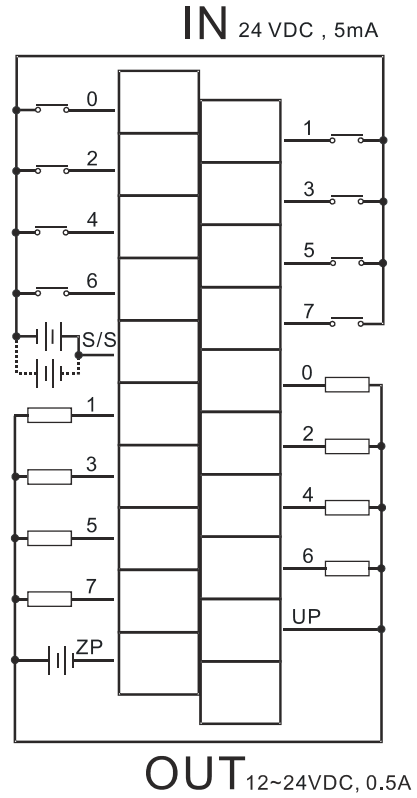
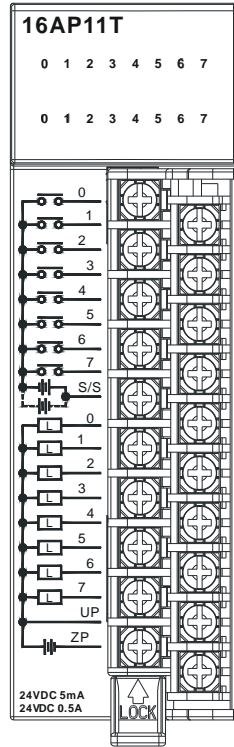

5

5.4.10 Wiring AH16AP11P-5A

Input form	Direct current (sinking or sourcing)
Input current	24 V DC, 5 mA
Output type	Transistor-P (sourcing)
Voltage specifications	12~24 V DC, 0.5 A

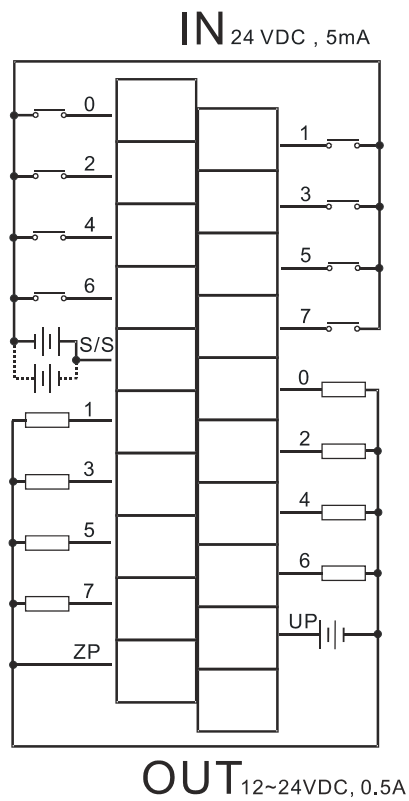
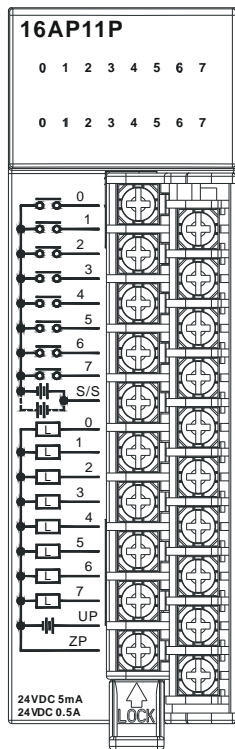

5

5.4.11 Wiring AH32AM10N-5A

Input form	Direct current (sinking or sourcing)
Input current	240 V DC, 5 mA

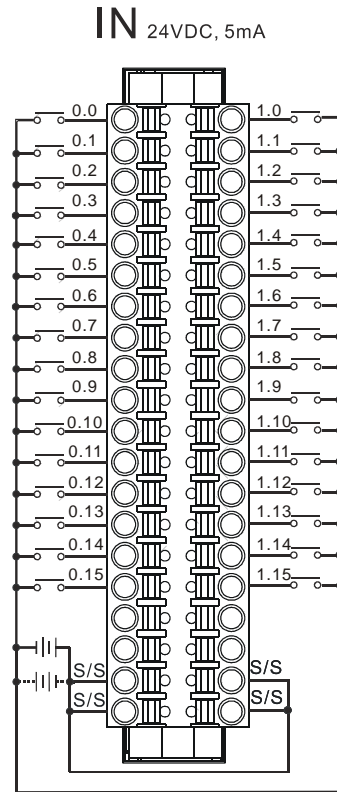
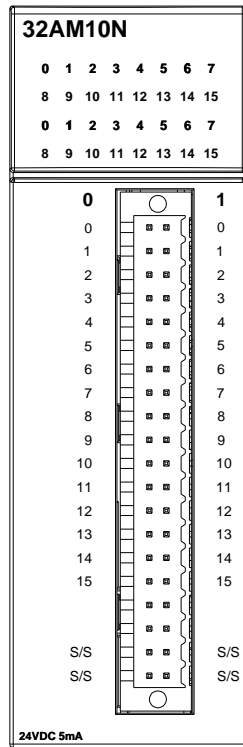

5

5.4.12 Wiring AH32AM10N-5B

Input form	Direct current (sinking or sourcing)
Input current	24 V DC, 5 mA

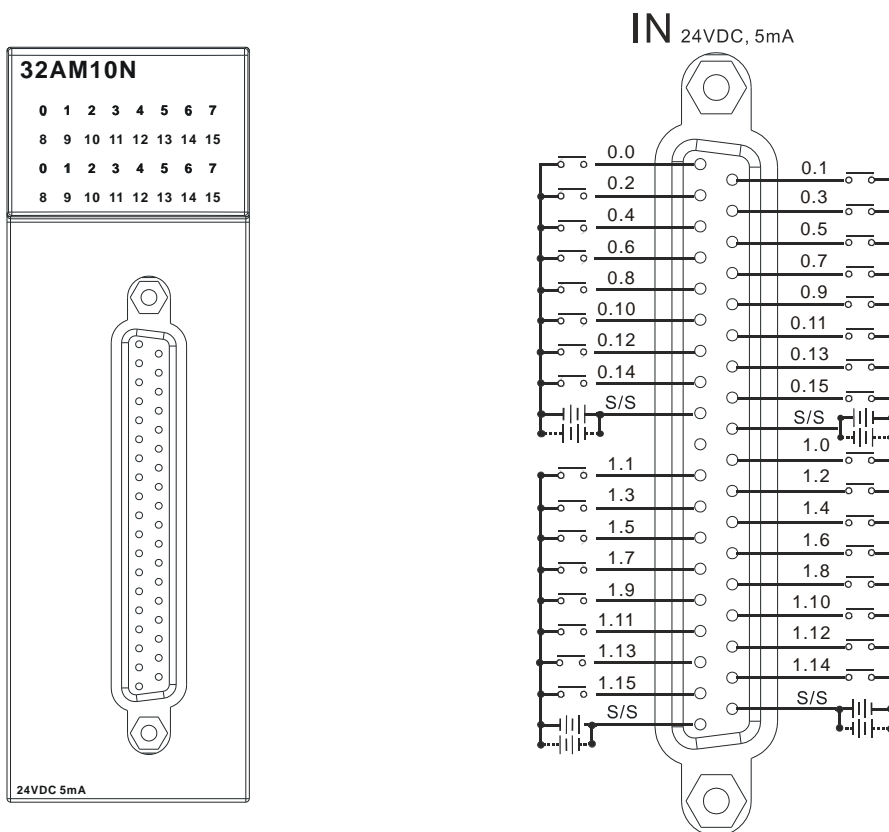

5

Wiring the external terminal module DVPAETB-ID32B:

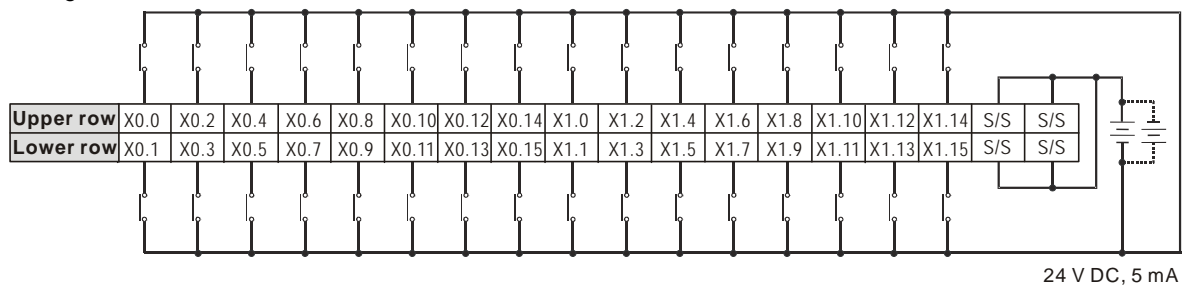

5.4.13 Wiring AH32AM10N-5C

Input form	Direct current (sinking or sourcing)
Input current	24 V DC, 5 mA

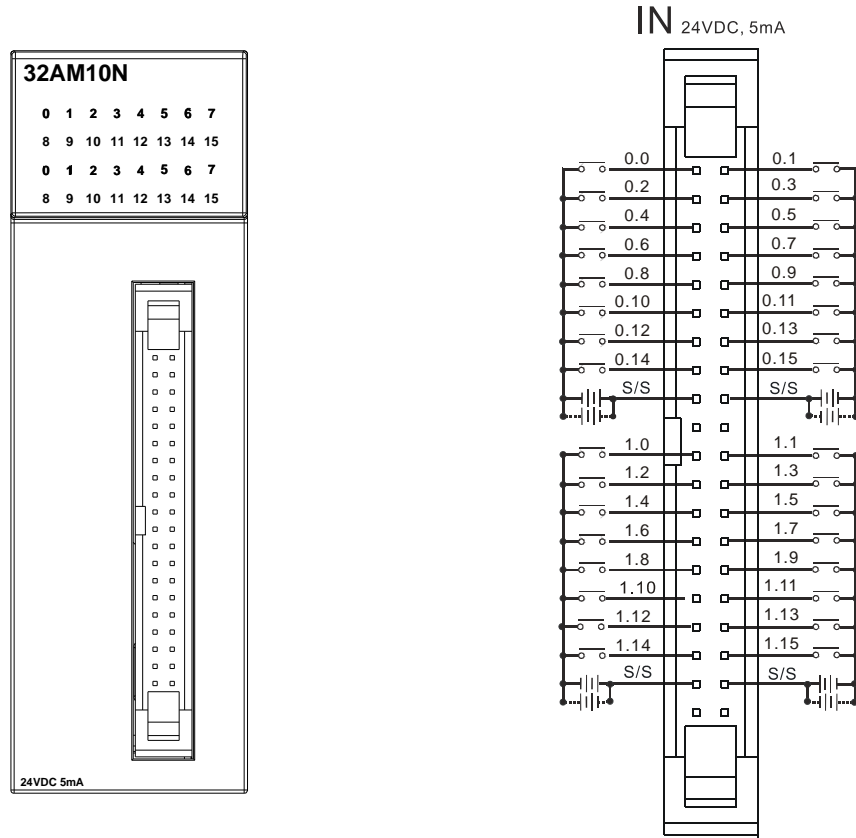

Wiring the external terminal module DVPAETB-ID32A:

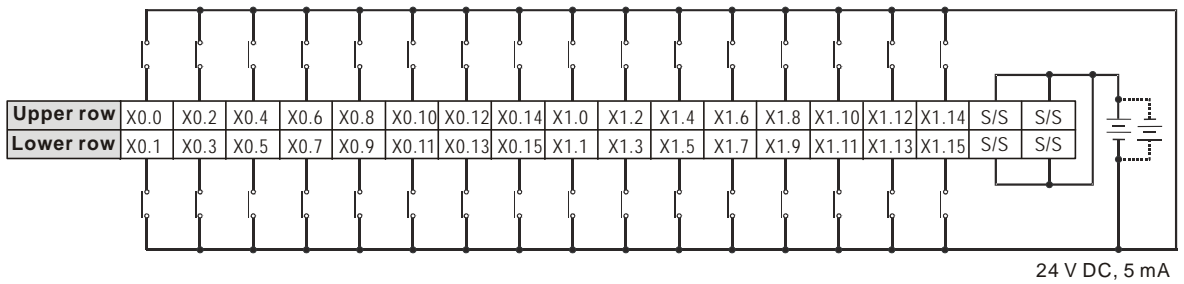

5.4.14 Wiring AH32AN02T-5A

Output type	Transistor-T (sinking)
Voltage specifications	12~24 V DC, 0.1 A

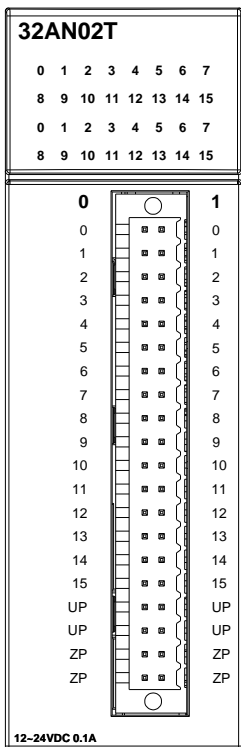

OUT 12~24VDC, 0.1A

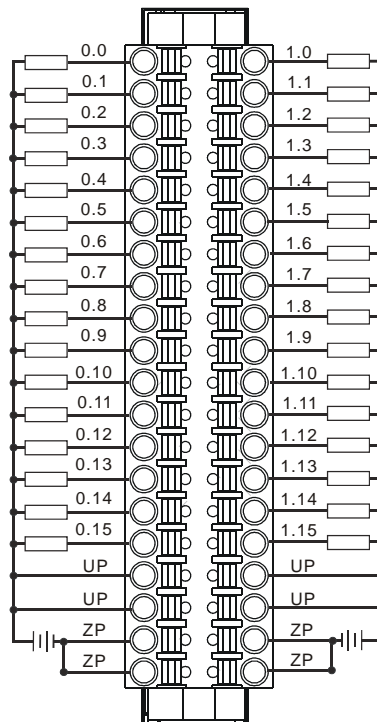

5

5.4.15 Wiring AH32AN02T-5B

Output type	Transistor-T (sinking)
Voltage specifications	12~24 V DC, 0.1 A

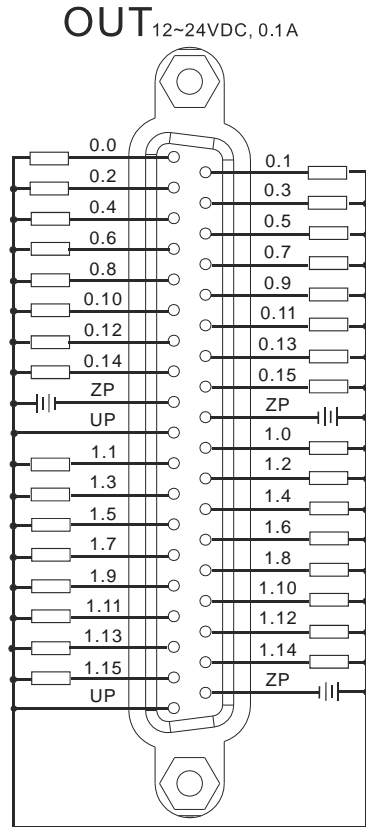
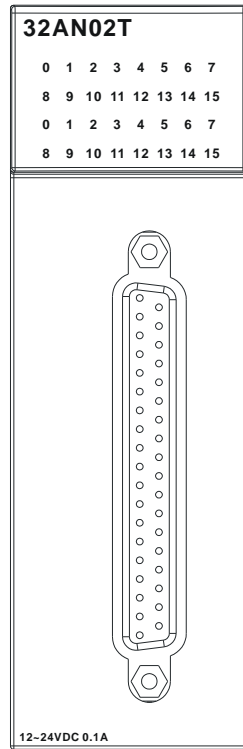

5

Wiring the external terminal module DVPAETB-OT32B:

Output type	Transistor-T (sinking)
Voltage specifications	12~24 V DC, 0.1 A

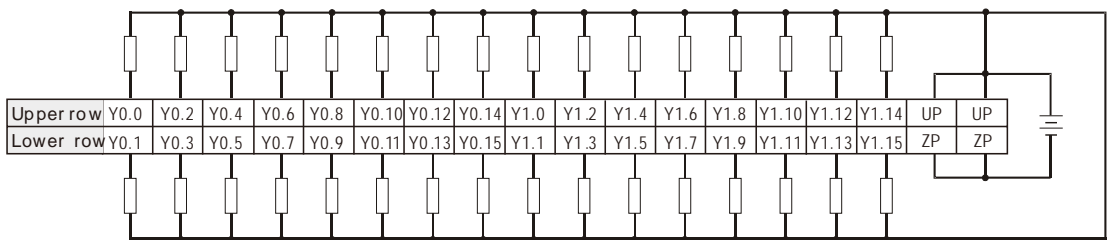

12~24VDC, 0.1A

Wiring the external terminal module DVPAETB-OR32A:

Output type	Relay-R
Voltage specifications	250 V AC, below 30 V DC

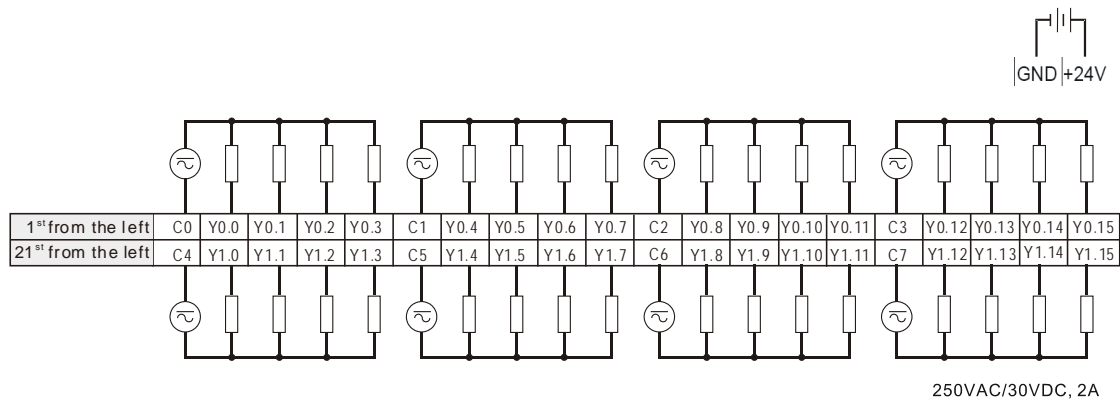

5.4.16 Wiring AH32AN02T-5C

Output type	Transistor-T (sinking)
Voltage specifications	12~24 V DC, 0.1 A

5

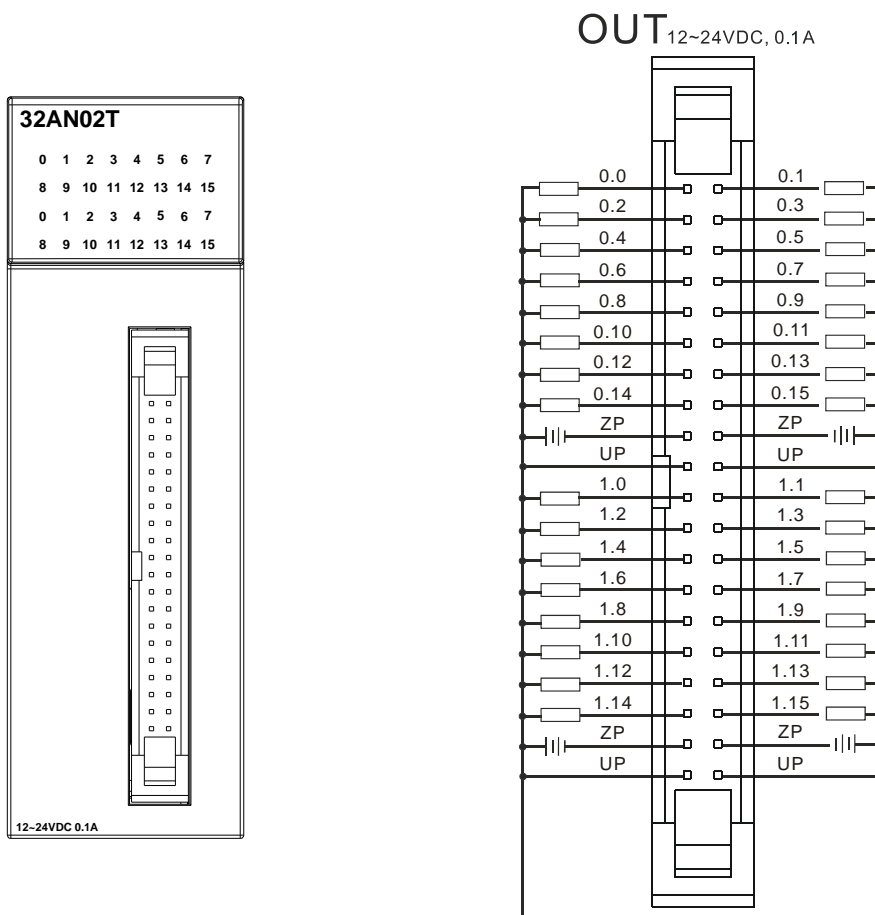

Wiring the external terminal module DVPAETB-OT32A:

Output type	Transistor-T (sinking)
Voltage specifications	12~24 V DC, 0.1 A

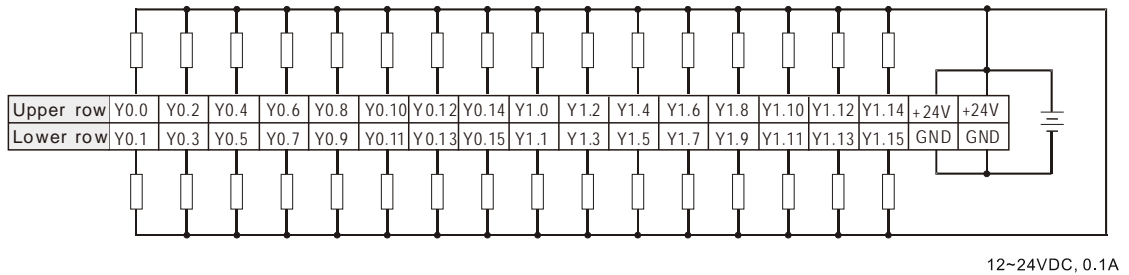

Wiring the external terminal module DVPAETB-OR16A:

Output type	Relay-R
Voltage specifications	250 V AC, below 30 V DC

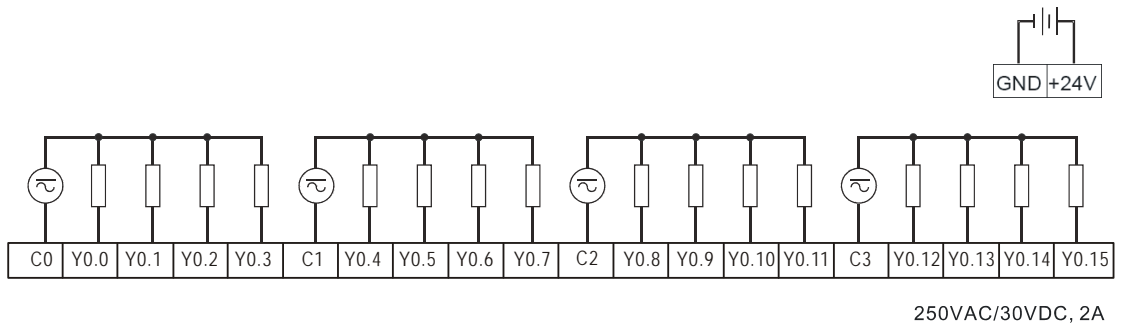

5.4.17 Wiring AH32AN02P-5A

Output type	Transistor-P (sourcing)
Voltage specifications	12~24 V DC, 0.1 A

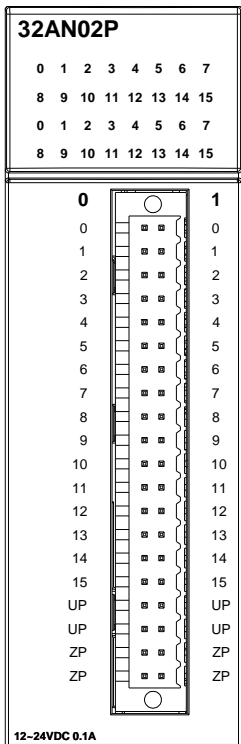

OUT 12~24VDC, 0.1A

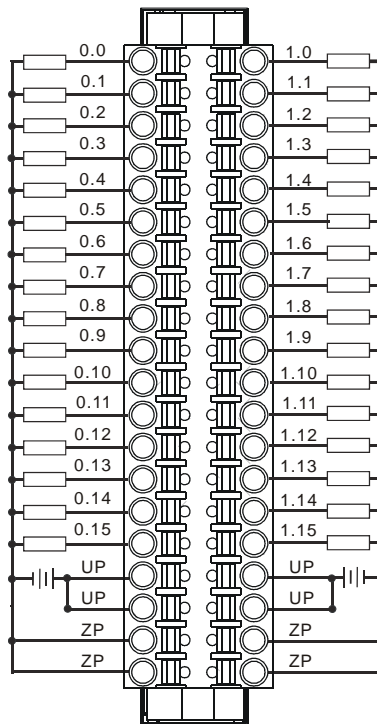

5

5.4.18 Wiring AH32AN02P-5B

Output type	Transistor-P (sourcing)
Voltage specifications	12~24 V DC, 0.1 A

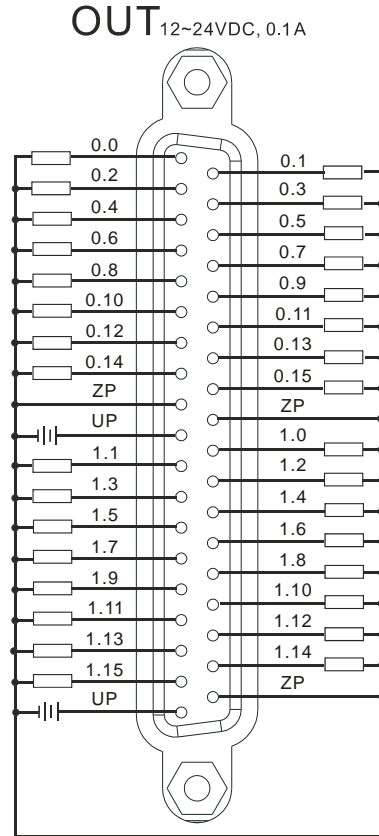
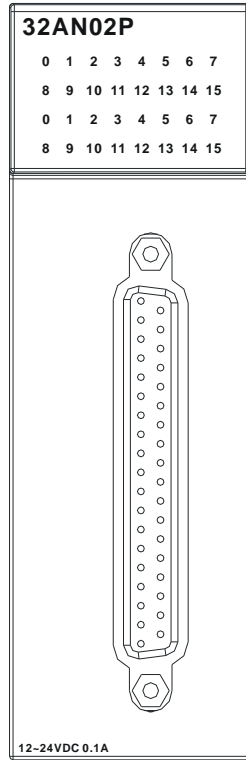

5

Wiring the external terminal module DVPAETB-OT32B:

Output type	Transistor-P (sourcing)
Voltage specifications	12~24 V DC, 0.1 A

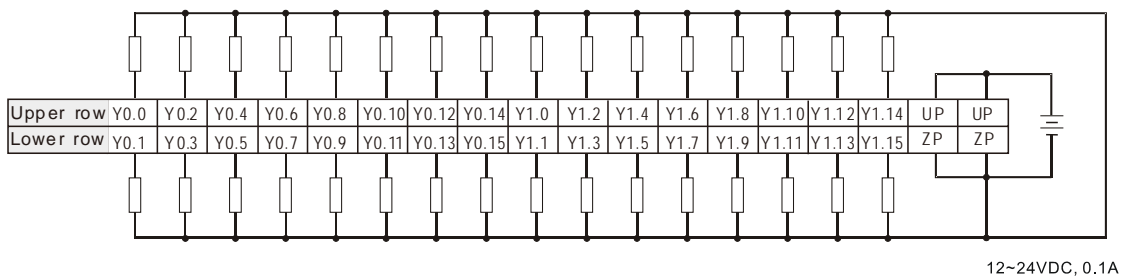

Wiring the external terminal module DVPAETB-OR32B:

Output type	Relay-R
Voltage specifications	250 V AC, below 30 V DC

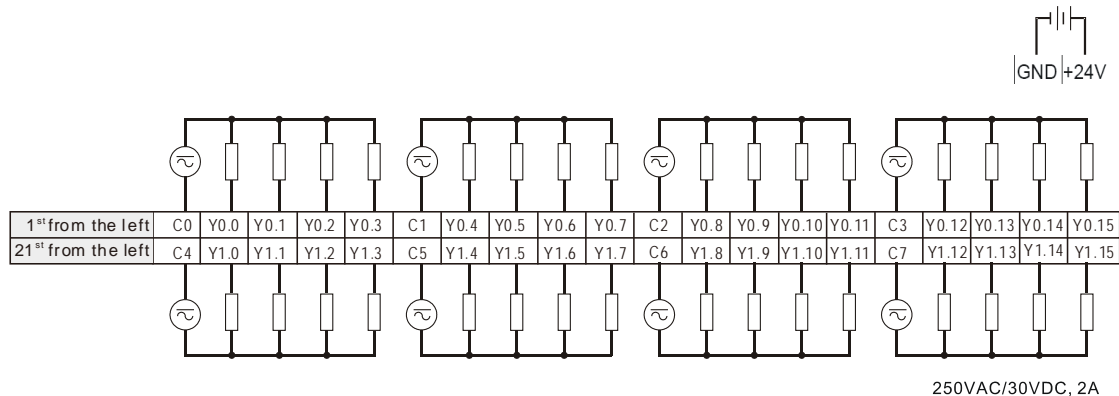

5.4.19 Wiring AH32AN02P-5C

Output type	Transistor-P (sourcing)
Voltage specifications	12~24 V DC, 0.1 A

5

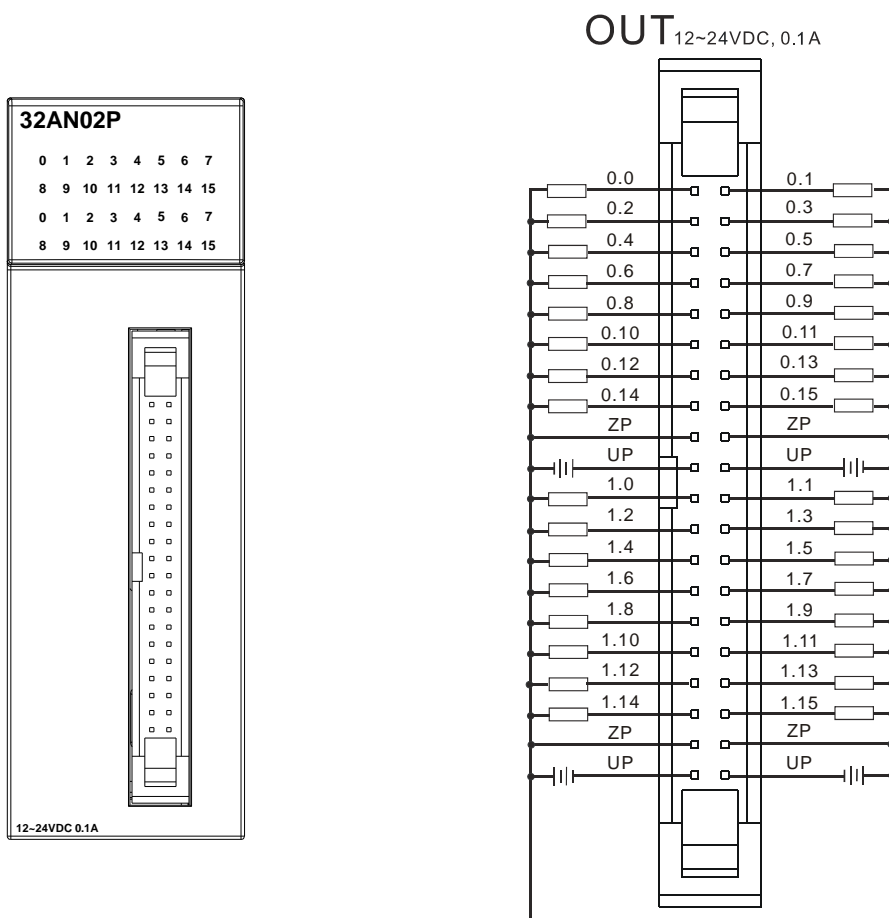

Wiring the external terminal module DVPAETB-OT32A:

Output type	Transistor-P (sourcing)
Voltage specifications	12~24 V DC, 0.1 A

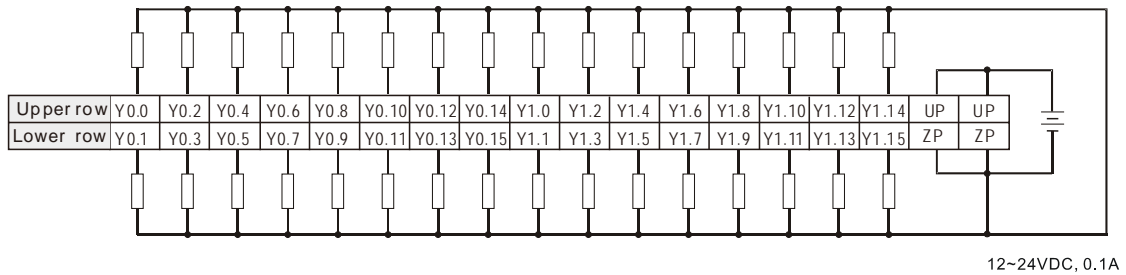

12~24VDC, 0.1A

Wiring the external terminal module DVPAETB-OR16B:

Output type	Relay-R
Voltage specifications	250 V AC, below 30 V DC

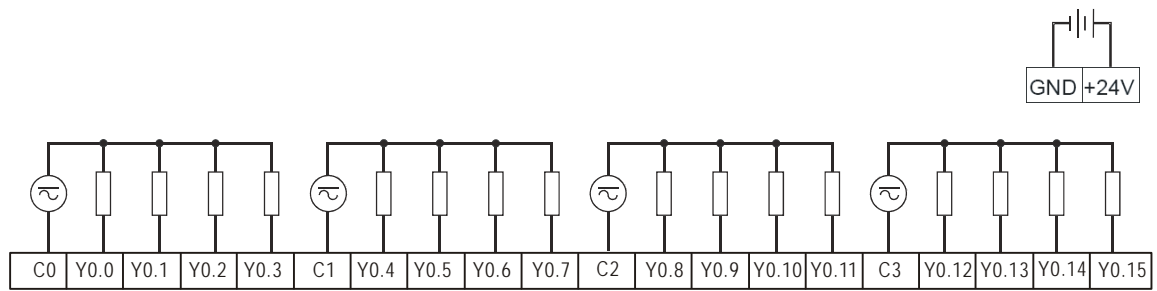

250VAC/30VDC, 2A

5.4.20 Wiring AH64AM10N-5C

Input form	Direct current (sinking or sourcing)
Input current	24 V DC, 5 mA

5

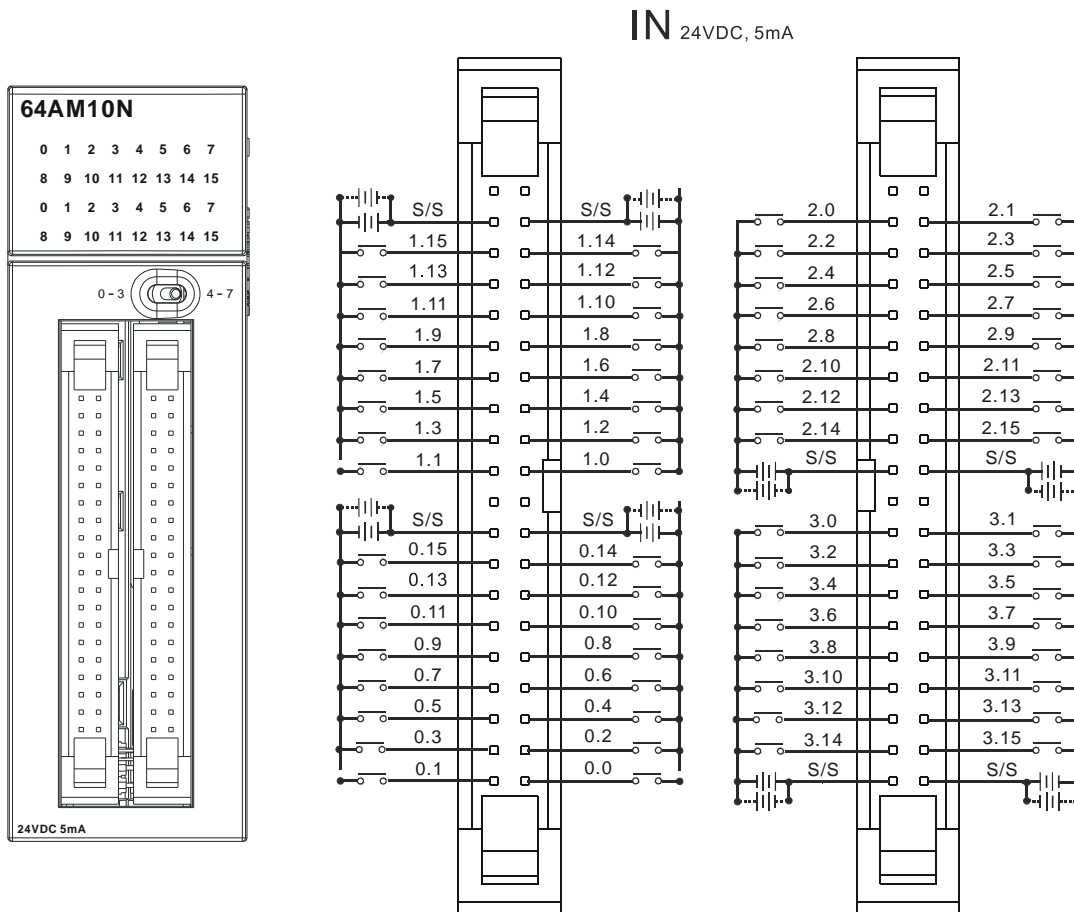

Wiring the external terminal module DVPAETB-ID32A:

Input form	Direct current (sinking or sourcing)
Input current	24 V DC, 5 mA

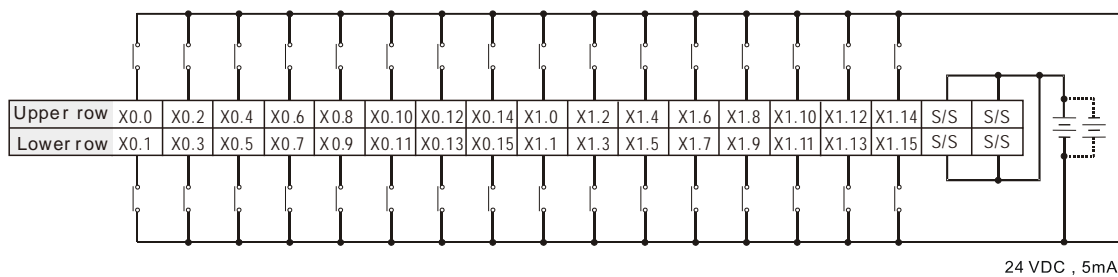

5.4.21 Wiring AH64AN02T-5C

Output type	Transistor-T (sinking)
Voltage specifications	12~24 V DC, 0.1 A

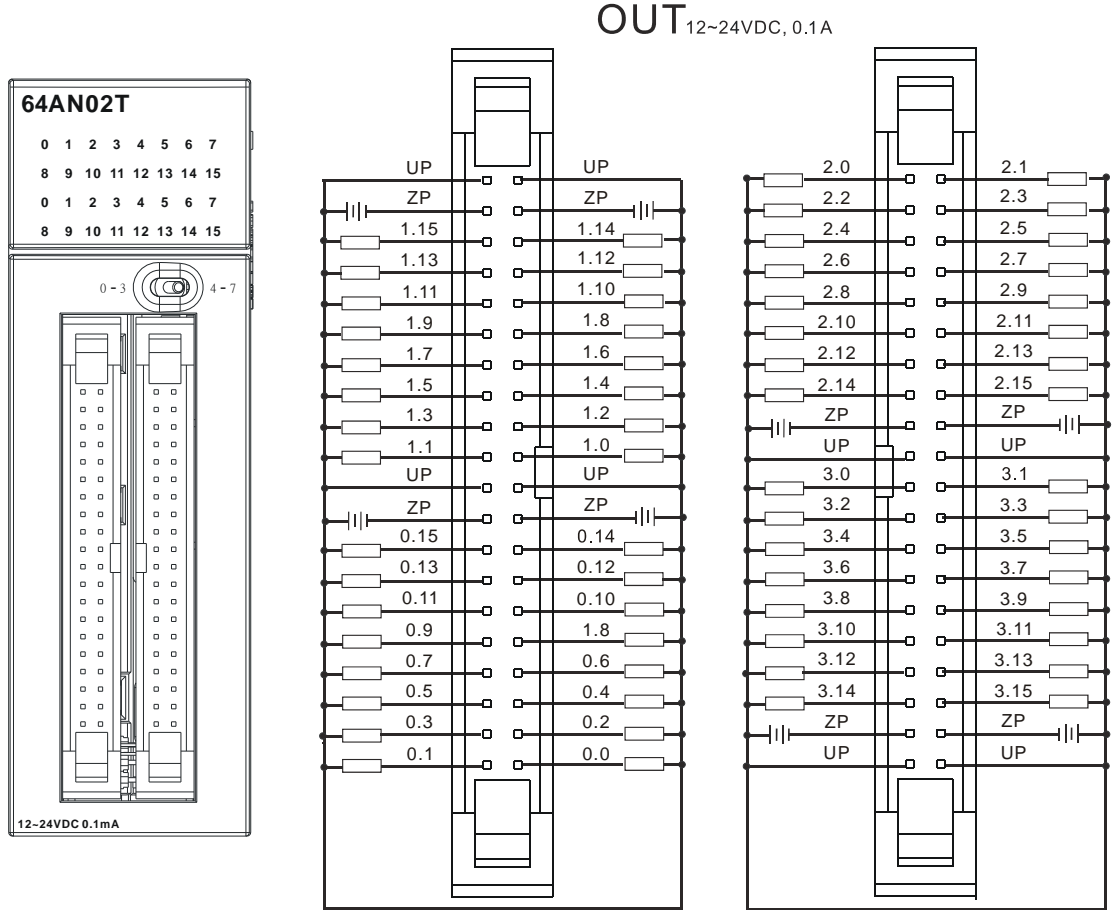

5

Wiring the external terminal module DVPAETB-OT32A:

Output type	Transistor-T (sinking)
Voltage specifications	12~24 V DC, 0.1 A

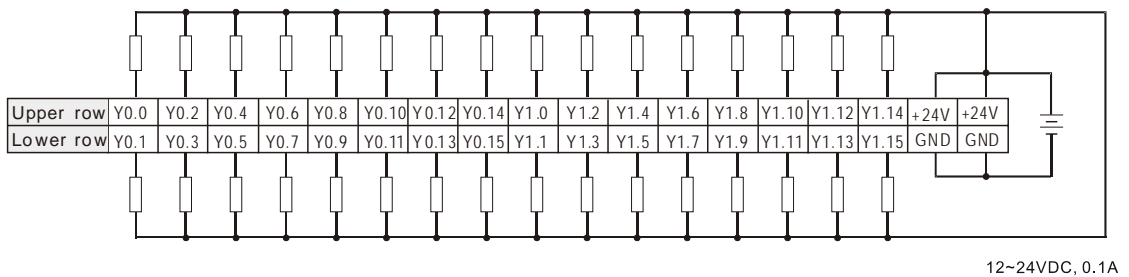

Wiring the external terminal module DVPAETB-OR16A:

Output type	Relay-R
Voltage specifications	250 V AC, below 30 V DC

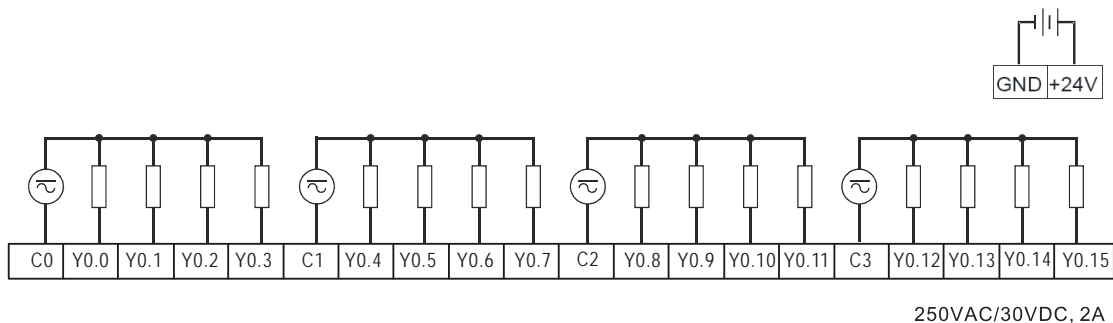

5.4.22 Wiring AH64AN02P-5C

Output type	Transistor-P (sourcing)
Voltage specifications	12~24 V DC, 0.1 A

5

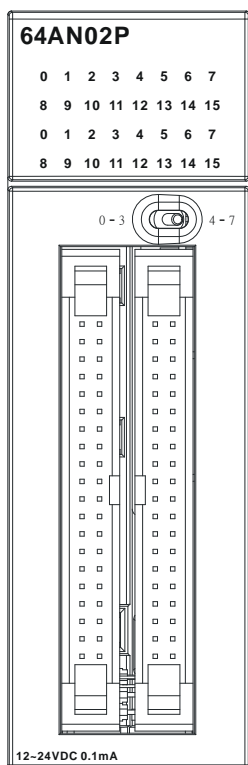

OUT_{12~24VDC, 0.1A}

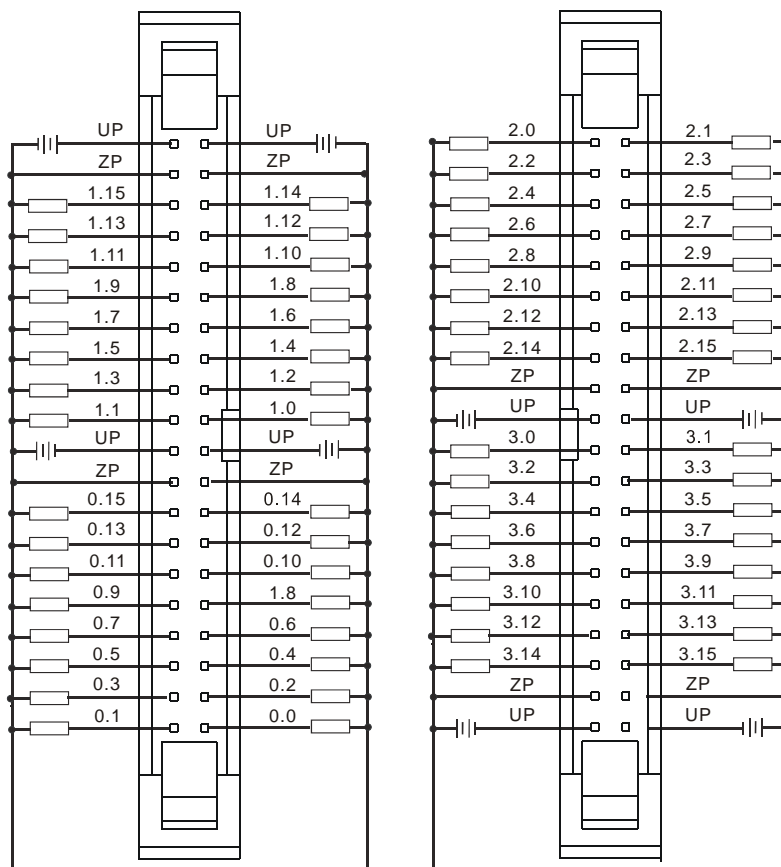

Wiring the external terminal module DVPAETB-OT32A:

Output type	Transistor-P (sourcing)
Voltage specifications	12~24 V DC, 0.1 A

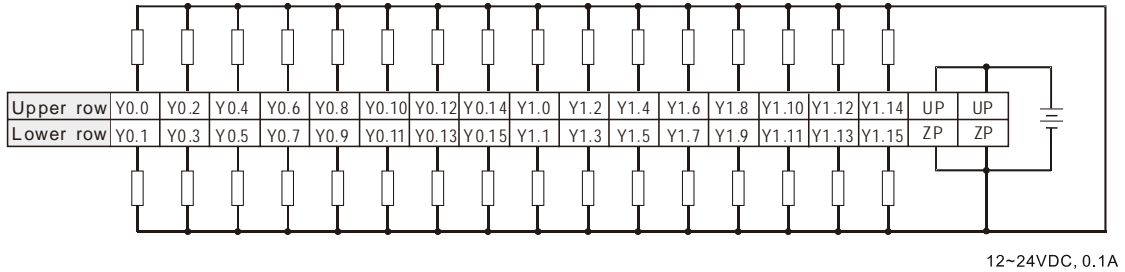

Wiring the external terminal module DVPAETB-OR16B:

Output type	Relay-R
Voltage specifications	250 V AC, below 30 V DC

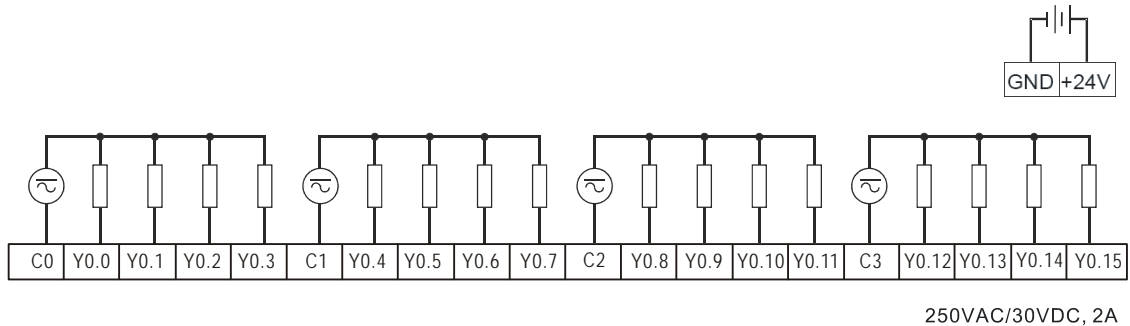

5

5.5 Wiring Digital Input/Output Terminals

5.5.1 Wiring Digital Input Terminals

5.5.1.1 Sinking and Sourcing

The input signal is the 24 V DC power input. Sinking and sourcing are current driving capabilities of a circuit. They are defined as follows.

<ul style="list-style-type: none"> ● Sinking Sinking=The current flows into the common terminal S/S. 	<ul style="list-style-type: none"> ● Sourcing Sourcing=The current flows from the common terminal S/S.
---	---

5.5.1.2 Relay Type

- Sinking

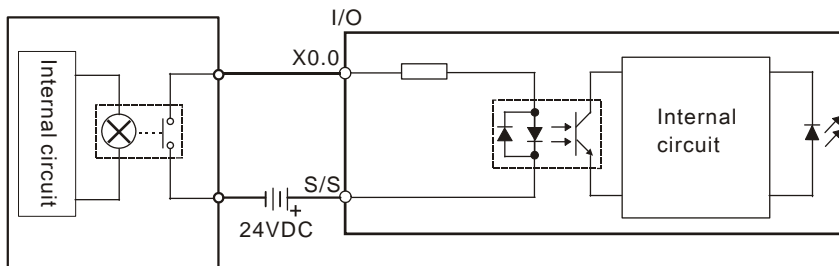

- Sourcing

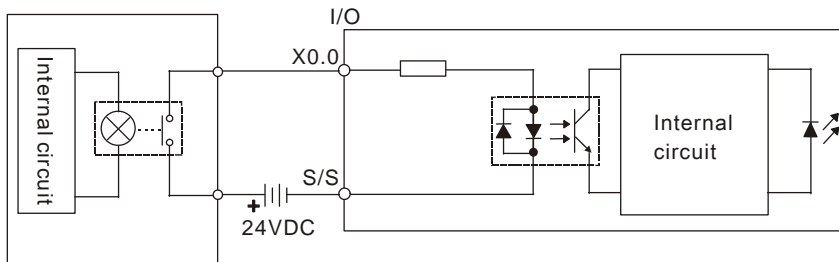

5

5.5.1.3 Open-collector Input Type

- Sinking
(NPN transistor whose collector is open)

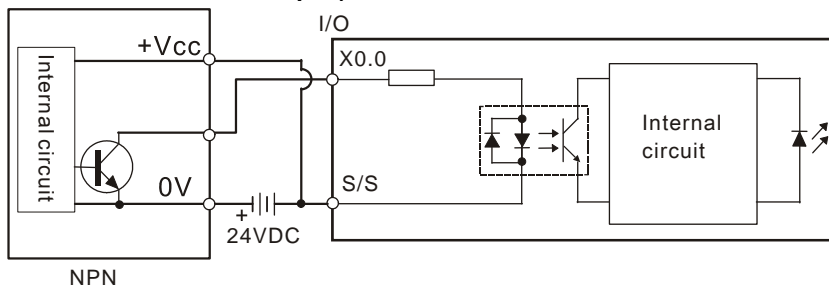

- Sourcing
(PNP transistor whose collector is open)

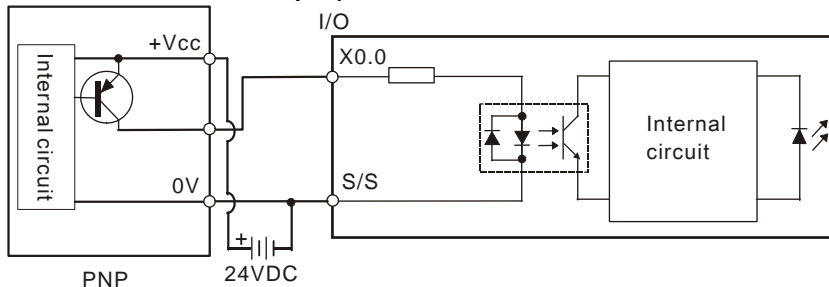

5.5.1.4 Two-wire Proximity Switch

Please use the two-wire proximity switch whose leakage current I_L is less than 1.5 mA when the switch is OFF. If the leakage current is larger than 1.5 mA, please connect the divider resistance R_b gotten from the formula below.

$$R_b \leq \frac{6}{I_L - 1.5} \text{ (k}\Omega\text{)}$$

- Sinking

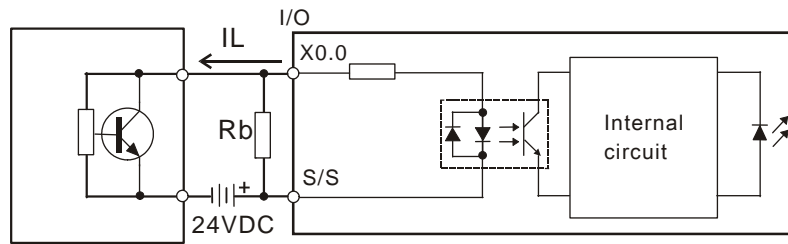

Two-wire proximity switch

- Sourcing

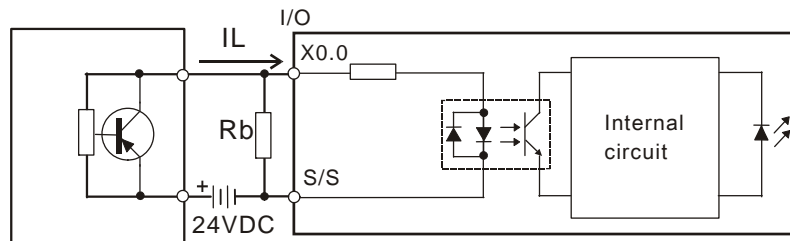

Two-wire proximity switch

5.5.1.5 Three-wire Switch

- Sinking

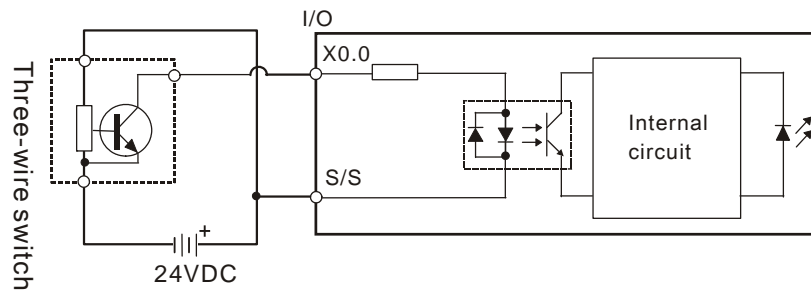

- Sourcing

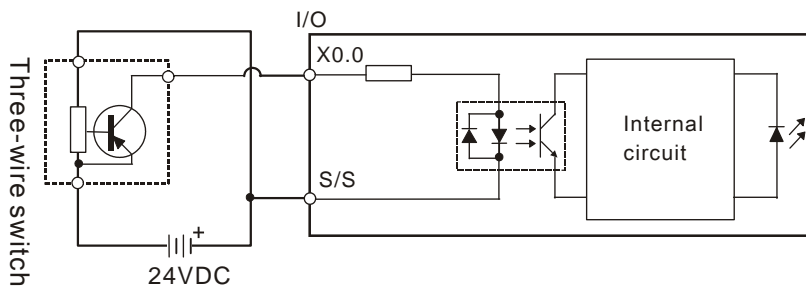

5.5.1.6 Optoelectronic Switch

- Sinking

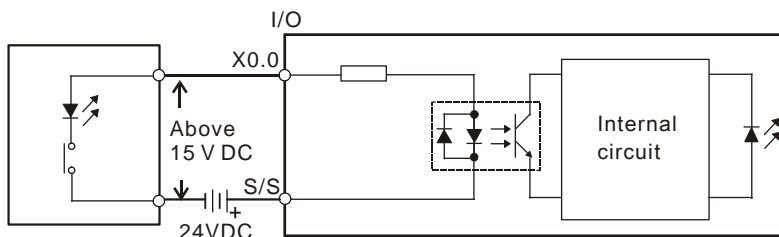

Optoelectronic switch

5

- Sourcing

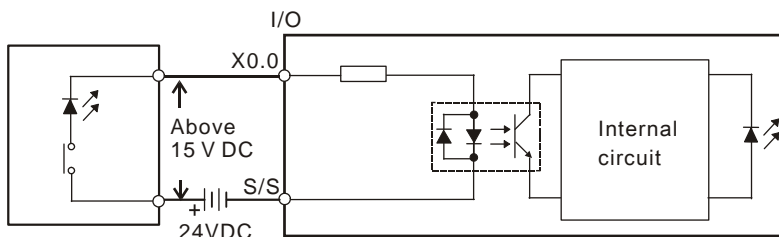

Optoelectronic switch

5.5.1.7 Voltage Input (120~240 V AC)

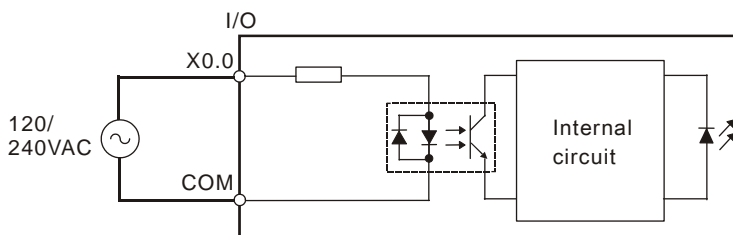

5.5.2 Wiring Digital Output Terminals

5.5.2.1 Output Circuits

There are three types of output units. They are relay outputs, transistor outputs, and TRIAC outputs.

1. Relay output

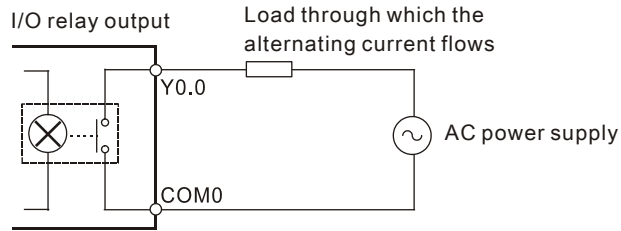

2. Transistor output

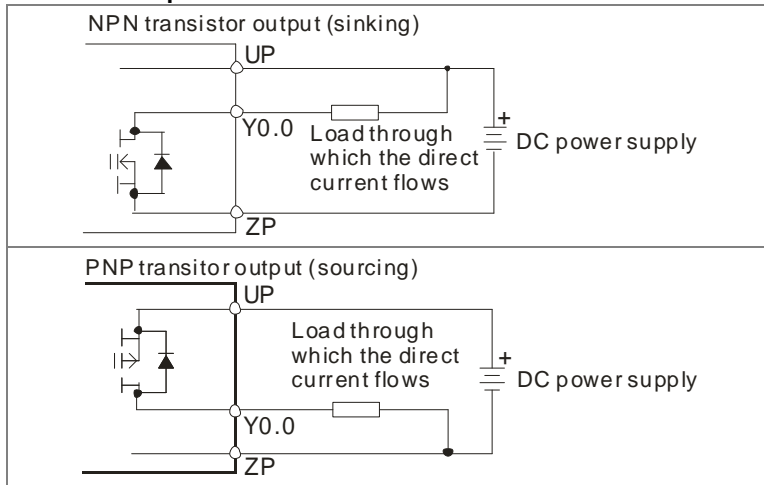

3. TRIAC output

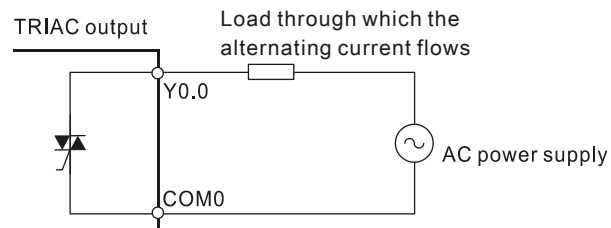

5.5.2.2 Relay Output Circuit

Relay terminals have no polarity. They can be applied to alternating current which passes through a load, or direct current which passes through a load. The maximum current which can pass through every relay terminal is 2 A, and the maximum current which can pass through every common terminal is 5 A. The lifetime of a relay terminal varies with the working voltage, the load type (the power factor $\cos \phi$), and the current passing through the terminal. The relation is shown in the life cycle curve below.

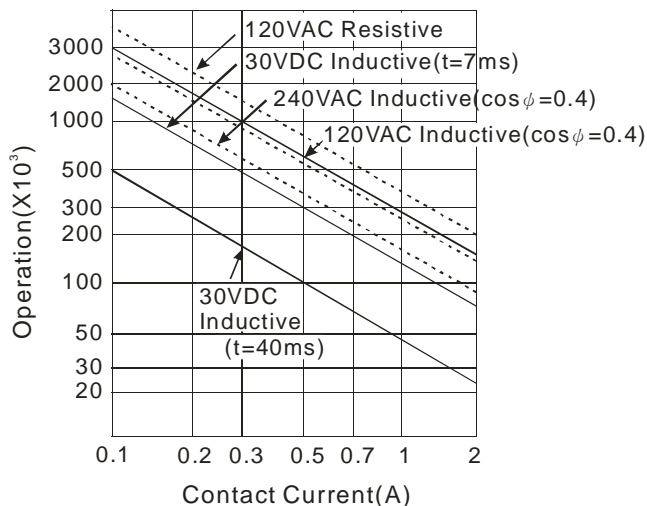

5

● Relay output circuit

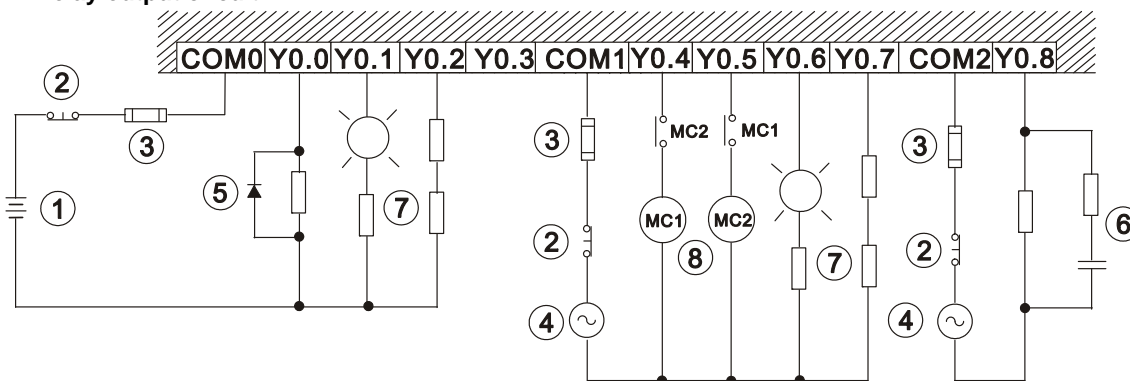

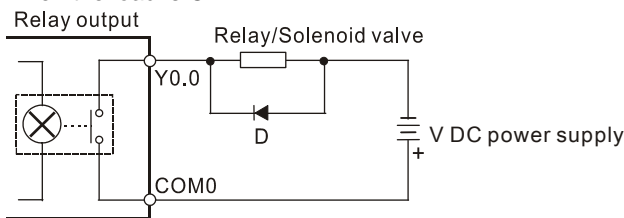
①	Direct-current power supply
②	Emergency stop: An external switch is used.
③	Fuse: To protect the output circuit, a fuse having a breaking capacity in the range of 5 A to 10 A is connected to the common terminal.
④	Alternating-current power supply
⑤	A relay or a solenoid valve is used as a DC load. A diode is connected in parallel to absorb the surge voltage which occurs when the load is OFF.  D: 1N4001 diode

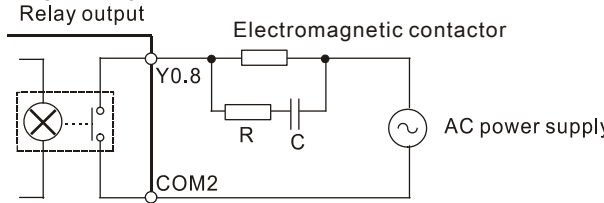
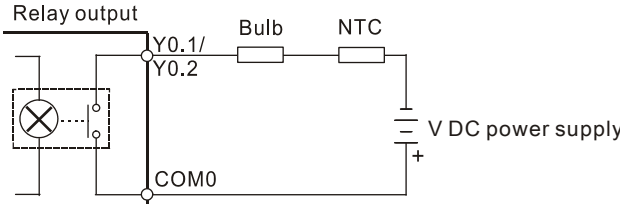
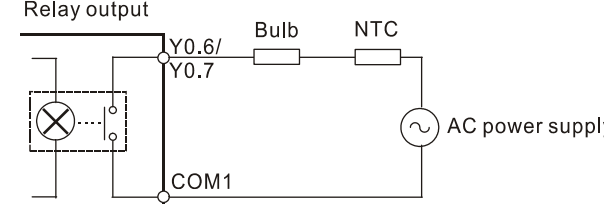
<p>⑥</p>	<p>An electromagnetic contactor is used as an AC load. A resistor and a capacitor are connected in parallel to absorb the surge voltage which occurs when the load is OFF.</p>  <p>R: 100~120 Ω C: 0.1~0.24 μF</p>
<p>⑦</p>	<p>A bulb (incandescent lamp) is used as a DC load. A thermistor is connected in series to absorb the surge current which occurs when the load is ON.</p>  <p>NTC: 10 Ω</p> <p>A bulb (neon lamp) is used as an AC load. A thermistor is connected in series to absorb the surge current which occurs when the load is ON.</p>  <p>NTC: 10 Ω</p>
<p>⑧</p>	<p>Mutually exclusive output: For example, Y0.4 controls the clockwise rotation of the motor, and Y0.5 controls the counterclockwise rotation of the motor. The interlock circuit which is formed, and the program in the PLC ensure that there are protective measures if an abnormal condition occurs.</p>

5.5.2.3 Transistor Output Circuit

The AH500 series transistor outputs are equipped with the diodes which provide the counter-electromotive force protection. They can be used if they are not turned ON/OFF frequently and there are low-power inductive loads. If they are turned ON/OFF frequently and there are high-power inductive loads, they must be connected to noise suppression circuits to reduce the noise and prevent the overvoltage or the overheating from damaging the transistor output circuit.

● **NPN/PNP transistor output circuit**

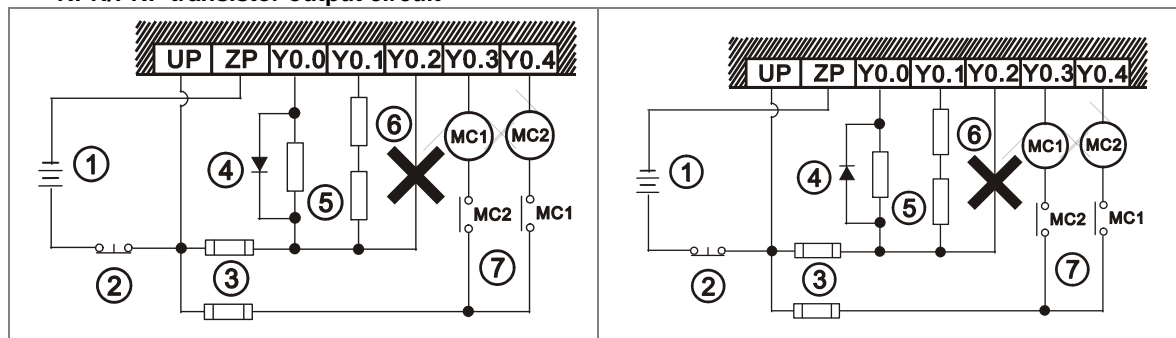

①	Direct-current power supply
②	Emergency stop
③	Fuse

The output terminals of a transistor module are open-collector output terminals. If Y0.0/Y0.1 is a pulse train output terminal of a transistor module, the output current passing through its output pull-up resistor must be greater than 0.1 A to ensure that the transistor module operates normally. A relay or a solenoid valve is used as a DC load. A diode is connected in parallel to absorb the surge voltage which occurs when the load is OFF.

5

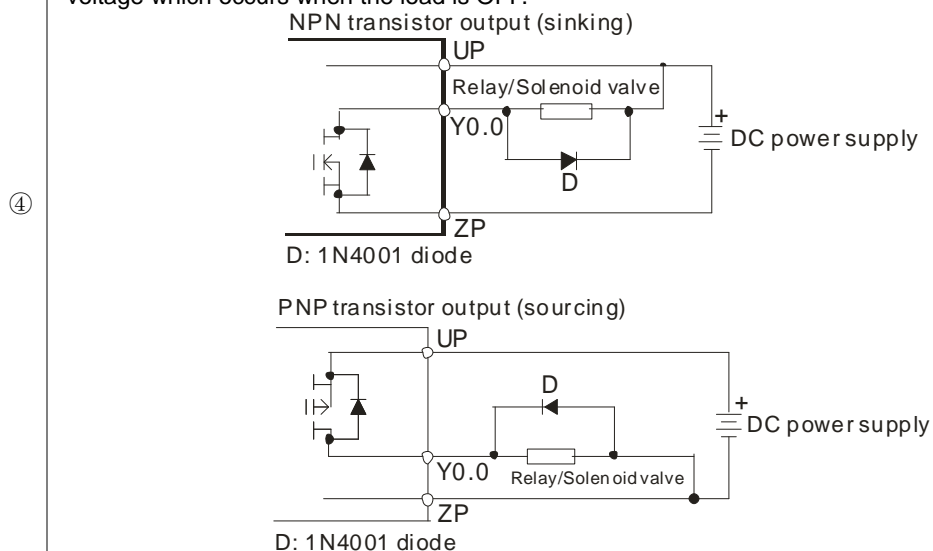

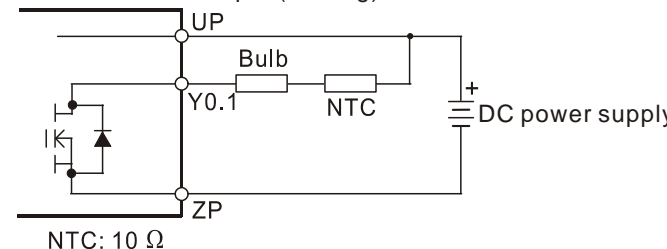
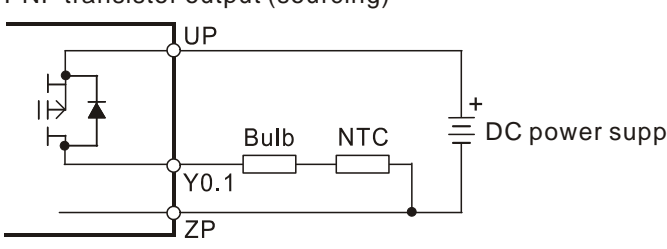
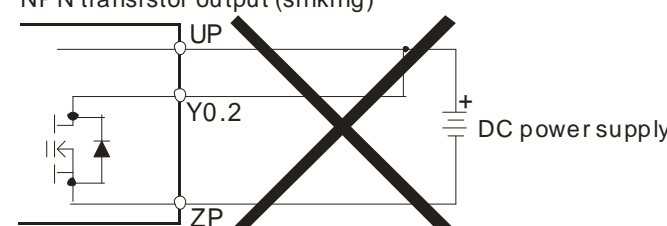
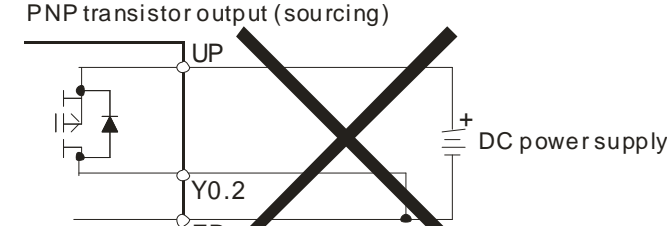
<p>⑤</p>	<p>A bulb (incandescent lamp) is used as a DC load. A thermistor is connected in series to absorb the surge current which occurs when the load is ON.</p> <p>NPN transistor output (sinking)</p>  <p>NTC: 10 Ω</p> <p>PNP transistor output (sourcing)</p>  <p>NTC: 10 Ω</p>
<p>⑥</p>	<p>Y0.2 can not be connected to a power supply directly. It must be connected to a load.</p> <p>NPN transistor output (sinking)</p>  <p>DC power supply</p> <p>PNP transistor output (sourcing)</p>  <p>DC power supply</p>
<p>⑦</p>	<p>Mutually exclusive output: For example, Y0.3 controls the clockwise rotation of the motor, and Y0.4 controls the counterclockwise rotation of the motor. The interlock circuit which is formed, and the program in the PLC ensure that there are protective measures if an abnormal condition occurs.</p>

5.5.2.4 TRIAC Output Circuit

TRIAC terminals only can be applied to alternating current which passes through a load. The maximum current which can pass through every TRIAC terminal is 0.5 A, and the maximum current which can pass through every common terminal is 2 A.

● TRIAC output circuit

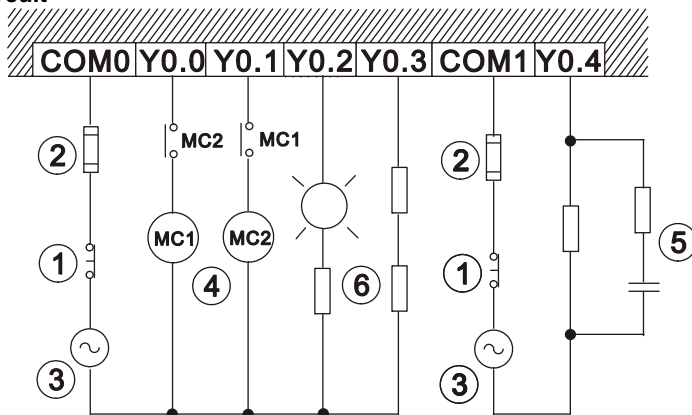

①	Emergency stop: An external switch is used.
②	Fuse: To protect the output circuit, a fuse having a breaking capacity in the range of 5 A to 10 A is connected to the common terminal.
③	Alternating-current power supply.
④	Mutually exclusive output: For example, Y0.0 controls the clockwise rotation of the motor, and Y0.1 controls the counterclockwise rotation of the motor. The interlock circuit which is formed, and the program in the PLC ensure that there are protective measures if an abnormal condition occurs.
⑤	<p>An electromagnetic contactor is used as an AC load. A resistor and a capacitor are connected in parallel to absorb the surge voltage which occurs when the load is OFF.</p> <p>R: 100~120 Ω C: 0.1~0.24μF</p>
⑥	<p>A bulb (neon lamp) is used as an AC load. A thermistor is connected in series to absorb the surge current which occurs when the load is ON.</p> <p>NTC: 10 Ω</p>

5

5.6 Wiring Analog Input/Output Modules

5.6.1 Wiring AH04AD-5A

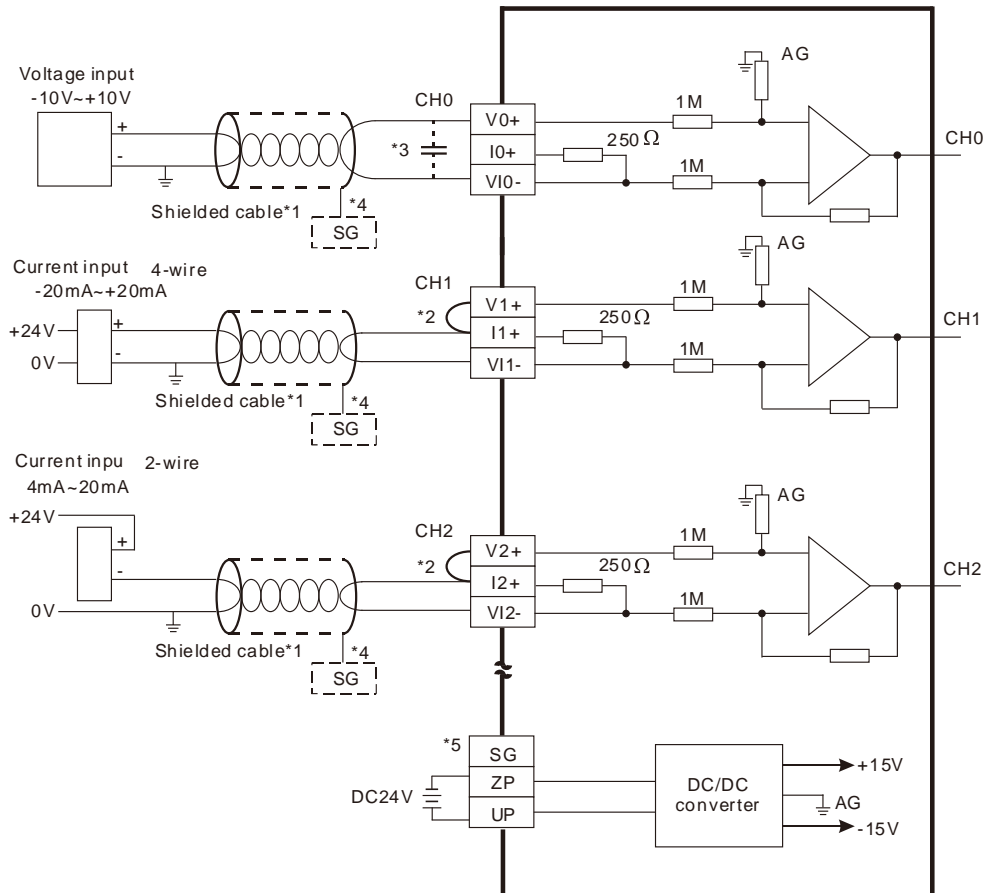

- *1. Please isolate the analog input signal cable from other power cables.
- *2. If the module is connected to a current signal, the terminals V+ and I+ must be short-circuited.
- *3. If the ripple in the input voltage results in the noise interference with the wiring, please connect the module to the capacitor having a capacitance in the range of 0.1 μF to 0.47 μF with a working voltage of 25 V.
- *4. Please connect the shielded cable to the terminal SG.
- *5. Once AH04AD-5A is installed on a backplane, the terminal SG on AH04AD-5A and the terminal \oplus on the backplane will be short-circuited. Please connect the terminal \oplus on the backplane to the ground terminal \oplus .

5.6.2 Wiring AH08AD-5B

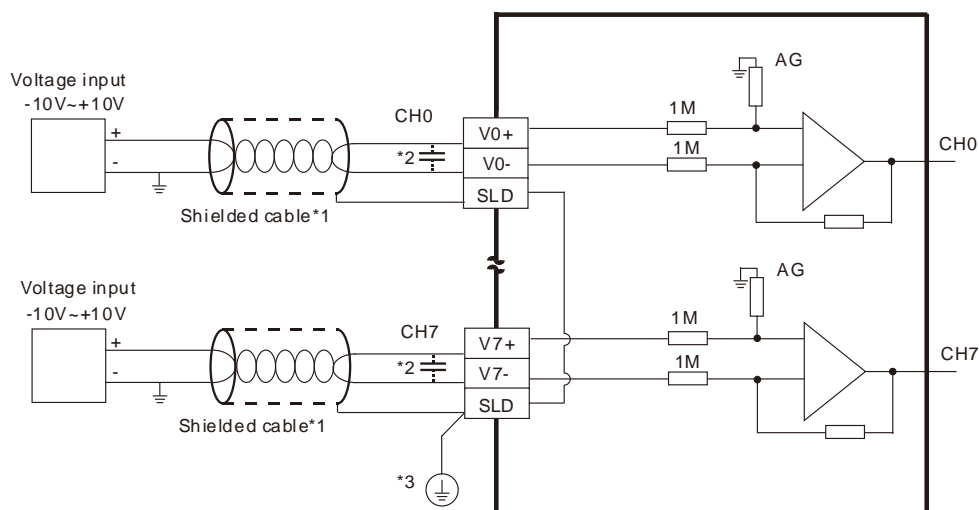

- *1. Please isolate the analog input signal cable from other power cables.
- *2. If the ripple in the input voltage results in the noise interference with the wiring, please connect the module to the capacitor having a capacitance in the range of $0.1 \mu\text{F}$ to $0.47 \mu\text{F}$ with a working voltage of 25 V.
- *3. Please connect the terminal SLD to the ground terminal \oplus .

5

5.6.3 Wiring AH08AD-5C

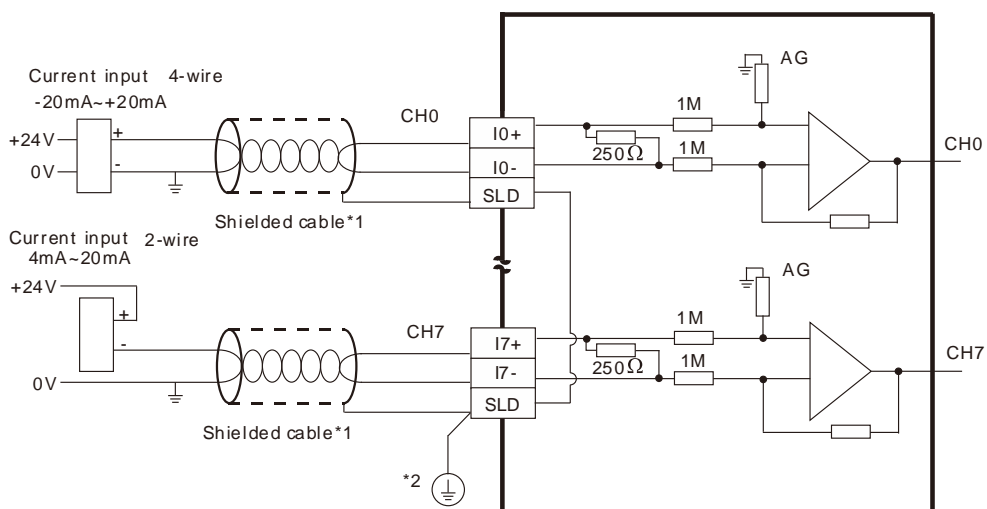

- *1. Please isolate the analog input signal cable from other power cables.
- *2. Please connect the terminal SLD to the ground terminal \oplus .

5.6.4 Wiring AH04DA-5A

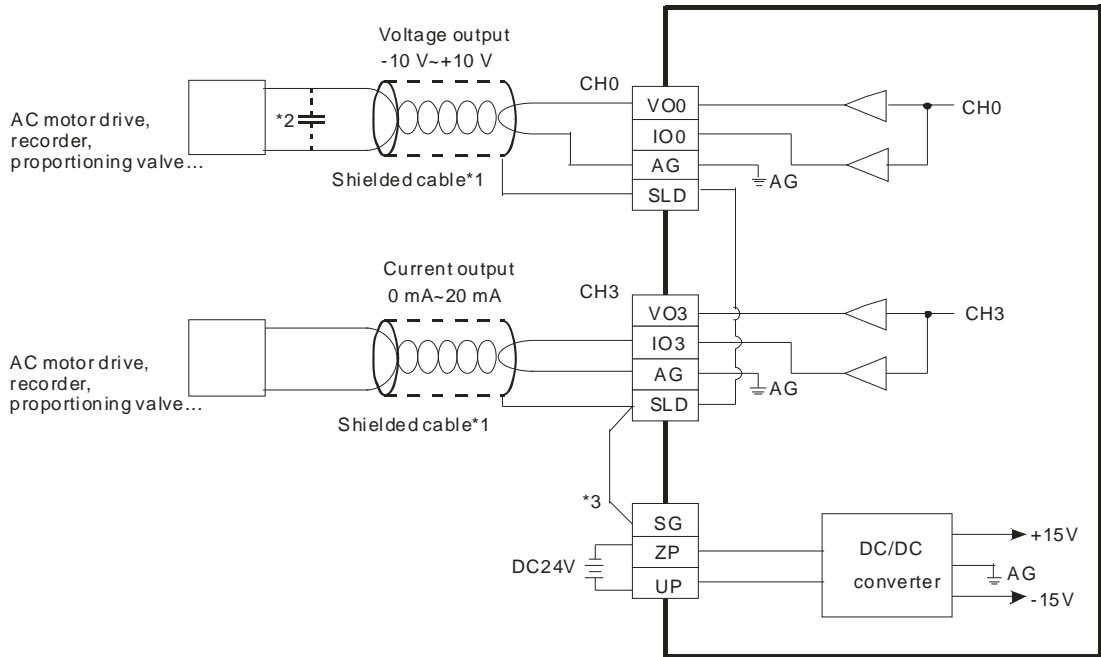

- *1. Please isolate the analog output signal cable from other power cables.
- *2. If a ripple is large for the input terminal of the load and results in the noise interference with the wiring, please connect the module to the capacitor having a capacitance in the range of 0.1 μF to 0.47 μF with a working voltage of 25 V.
- *3. Please connect the terminal SLD to the terminal SG. Once AH04DA-5A is installed on a backplane, the terminal SG on AH04DA-5A and the terminal \oplus on the backplane will be short-circuited. Please connect the terminal \oplus on the backplane to the ground terminal \oplus .

5

5.6.5 Wiring AH08DA-5B

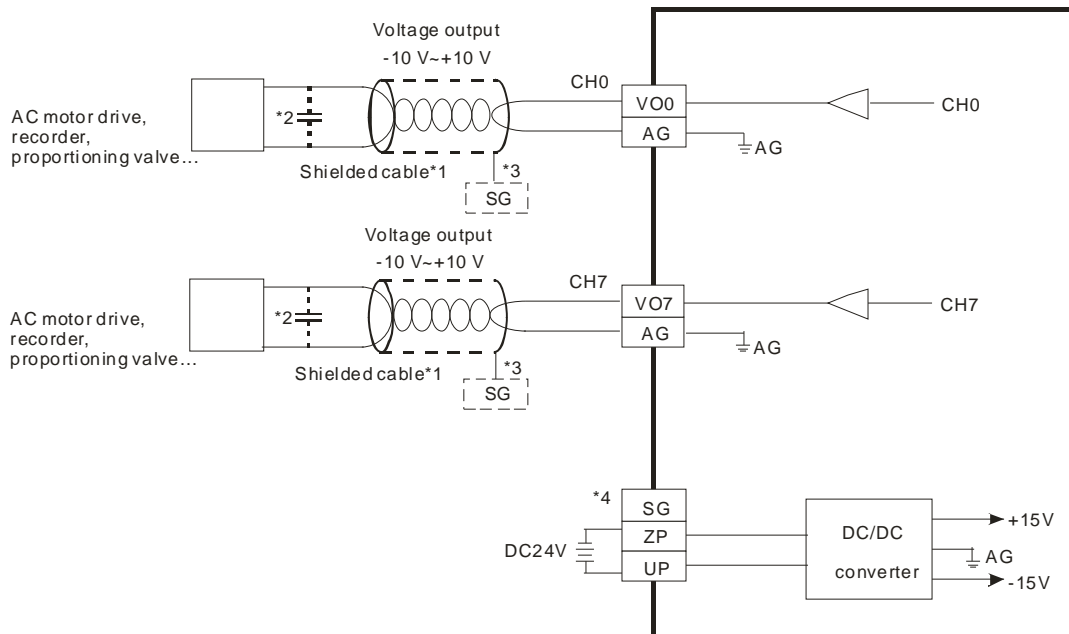

5

- *1. Please isolate the analog output signal cable from other power cables.
- *2. If a ripple is large for the input terminal of the load and results in the noise interference with the wiring, please connect the module to the capacitor having a capacitance in the range of 0.1 μF to 0.47 μF with a working voltage of 25 V.
- *3. Please connect the shielded cable to the terminal SG.
- *4. Once AH08DA-5B is installed on a backplane, the terminal SG on AH08DA-5B and the terminal ⏏ on the backplane will be short-circuited. Please connect the terminal ⏏ on the backplane to the ground terminal ⏏ .

5.6.6 Wiring AH08DA-5C

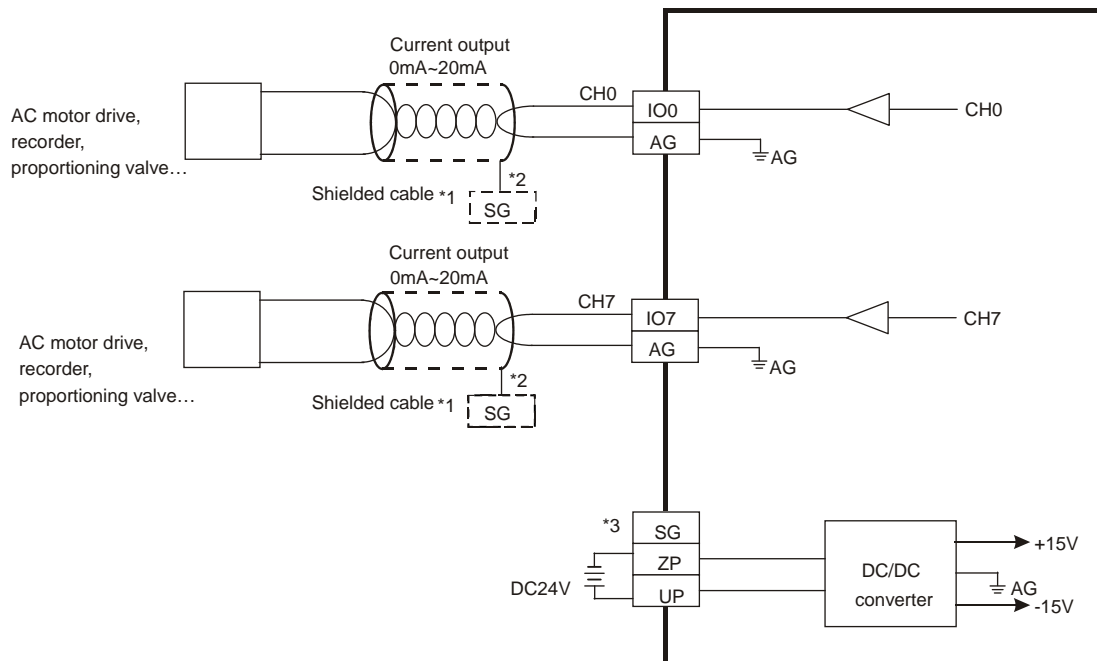

- *1. Please isolate the analog output signal cable from other power cables.
- *2. Please connect the shielded cable to the terminal SG.
- *3. Once AH08DA-5C is installed on a backplane, the terminal SG on AH08DA-5C and the terminal \oplus on the backplane will be short-circuited. Please connect the terminal \oplus on the backplane to the ground terminal \oplus .

5

5.6.7 Wiring AH06XA-5A

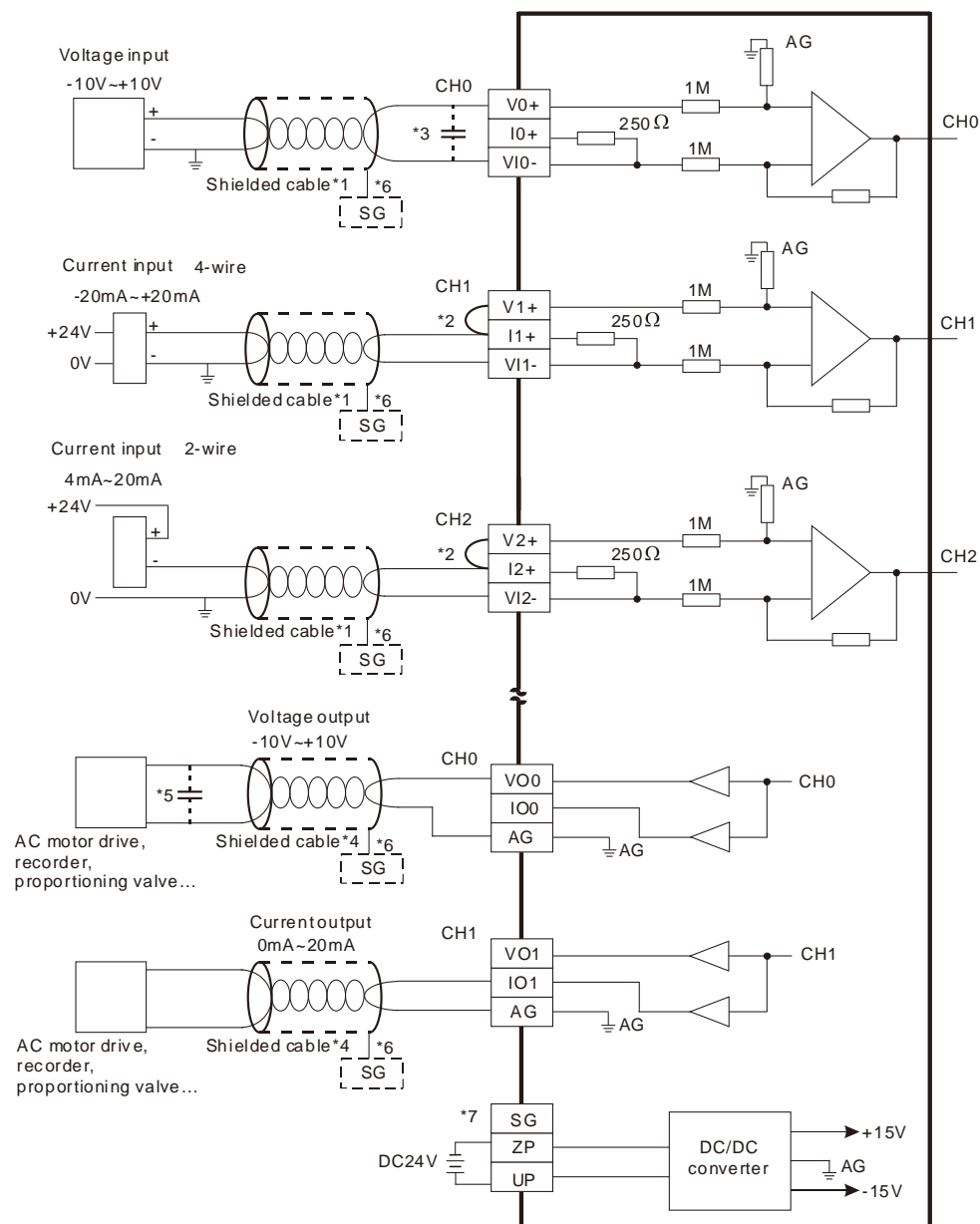

5

- *1. Please isolate the analog input signal cable from other power cables.
- *2. If the module is connected to a current signal, the terminals V1+ and I1+ must be short-circuited, and the terminals V2+ and I2+ must be short-circuited.
- *3. If the ripple in the input voltage results in the noise interference with the wiring, please connect the module to the capacitor having a capacitance in the range of 0.1 μF to 0.47 μF with a working voltage of 25 V.
- *4. Please isolate the analog output signal cable from other power cables.
- *5. If a ripple is large for the input terminal of the load and results in the noise interference with the wiring, please connect the module to the capacitor having a capacitance in the range of 0.1 μF to 0.47 μF with a working voltage of 25 V.
- *6. Please connect the shielded cables to the terminal SG.
- *7. Once AH06XA-5A is installed on a backplane, the terminal SG on AH06XA-5A and the terminal ⏏ on the backplane will be short-circuited. Please connect the terminal ⏏ on the backplane to the ground terminal ⏏ .

5.7 Wiring Temperature Measurement Modules

5.7.1 Wiring AH04PT-5A

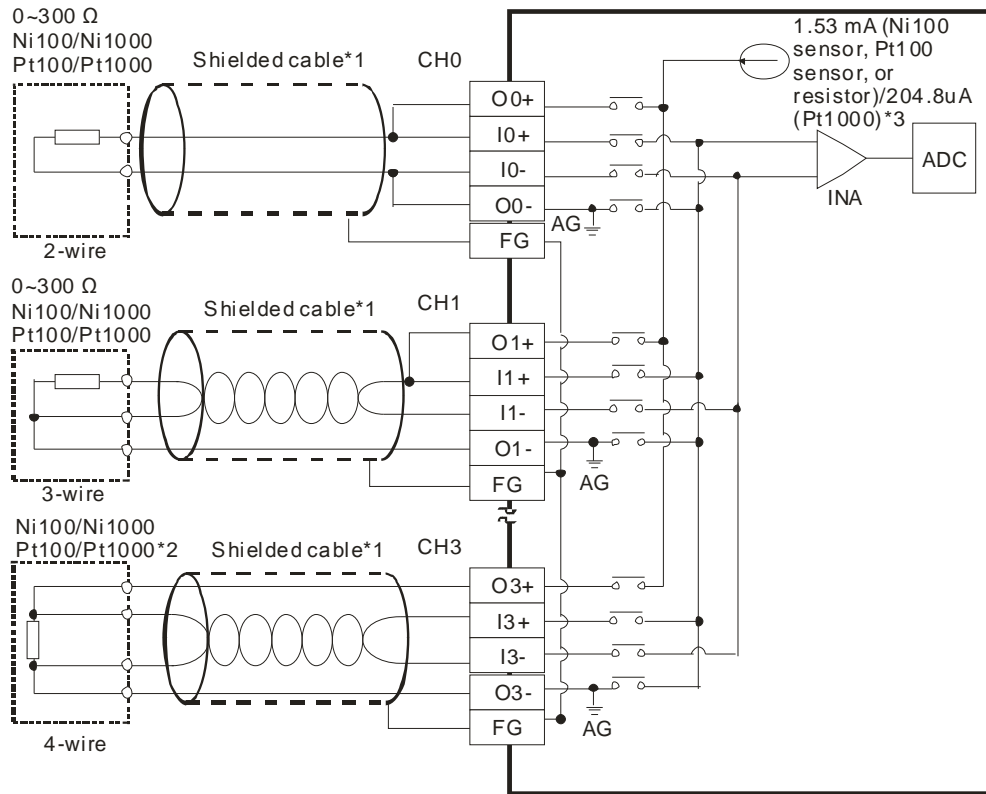

5

- *1. The cable connected to the input terminal should be the cable or the shielded twisted pair cable which can be connected to an Ni100/Ni1000/Pt100/Pt1000 sensor, and should be kept separate from other power cables and cables which generate noise. Please use a three-wire temperature sensor. If users want to use a two-wire temperature sensor, **On+** and **In+** must be short-circuited, and **On-** and **In-** must be short-circuited. (**n** is in the range of 0 to 3.)
- *2. If users want to measure resistance in the range of 0 Ω to 300 Ω, they can use a two-wire or three-wire sensor instead of a four-wire sensor.
- *3. Users need to select an appropriate sensor. If an Ni100 temperature sensor, a Pt100 temperature sensor, or a resistance sensor is used, the internal excitation current is 1.53 mA. If an Ni1000 temperature sensor, or a Pt1000 temperature sensor is used, the internal excitation current is 204.8 μA.

5.7.2 Wiring AH08PTG-5A

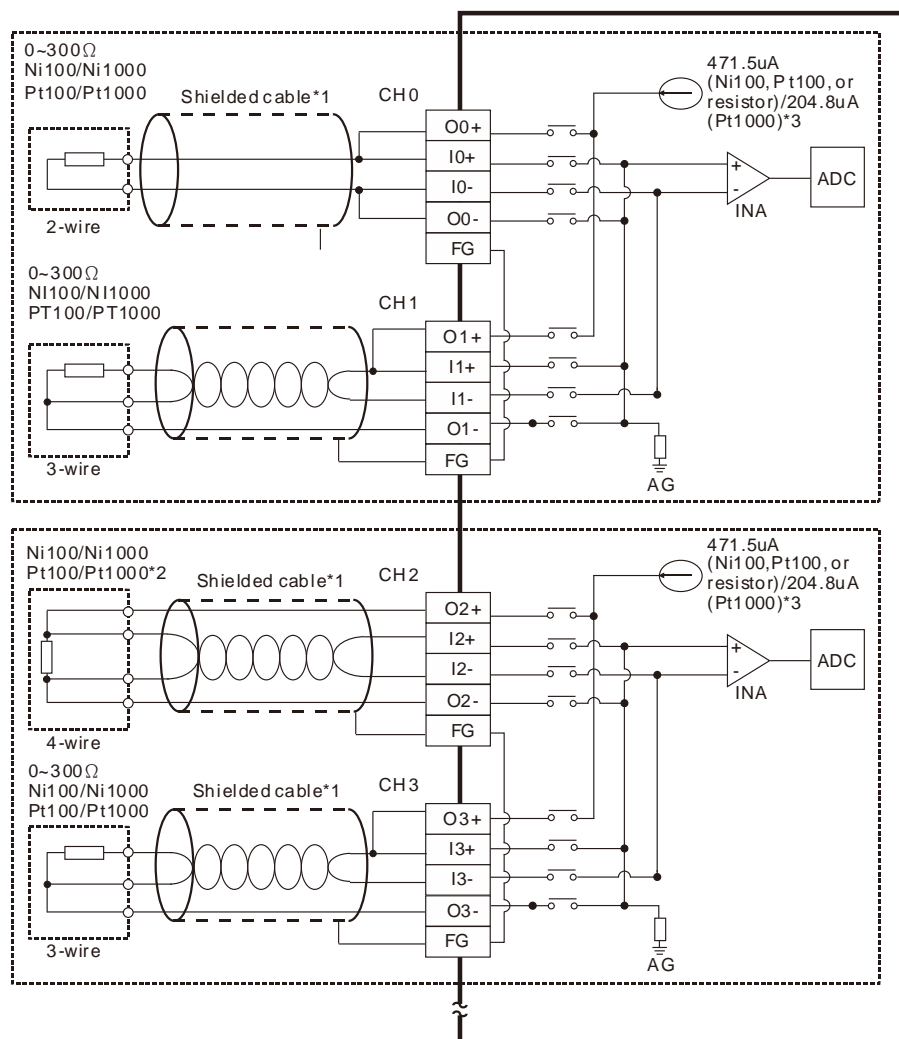

5

- *1. The cable connected to the input terminal should be the cable or the shielded twisted pair cable which can be connected to an Ni100/Ni1000/Pt100/Pt1000 sensor, and should be kept separate from other power cables and cables which generate noise. Please use a three-wire temperature sensor. If users want to use a two-wire temperature sensor, On+ and In+ must be short-circuited, and On- and In- must be short-circuited. (n is in the range of 0 to 7.)
- *2. If users want to measure resistance in the range of 0 Ω to 300 Ω, they can use a two-wire or three-wire sensor instead of a four-wire sensor.
- *3. User need to select an appropriate sensor. If an Ni100 temperature sensor, a Pt100 temperature sensor, or a resistance sensor is used, the internal excitation current is 471.5 μA. If an Ni1000 temperature sensor, or a Pt1000 temperature sensor is used, the internal excitation current is 204.8 μA.

5.7.3 Wiring AH04TC-5A

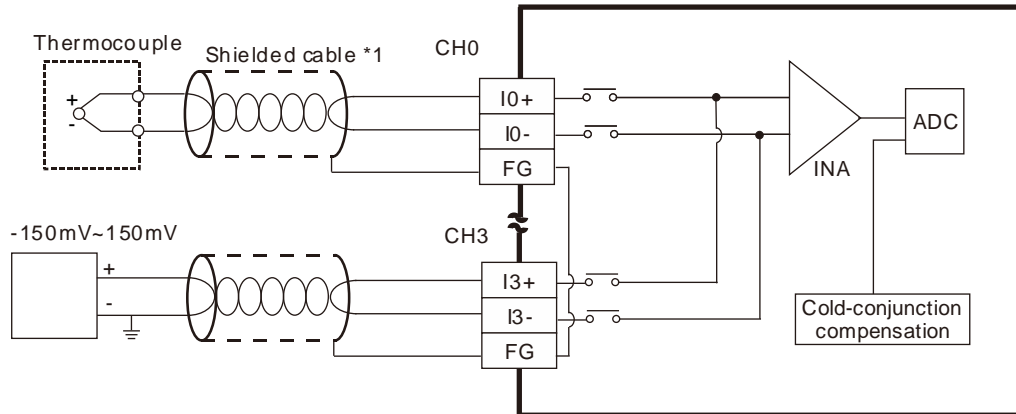

*1. The cable connected to the input terminal should be the cable or the shielded twisted pair cable which can be connected to a type J, type K, type R, type S, type T, type E, or type N thermocouple, and should be kept separate from other power cables and cables which generate noise.

5.7.4 Wiring AH08TC-5A

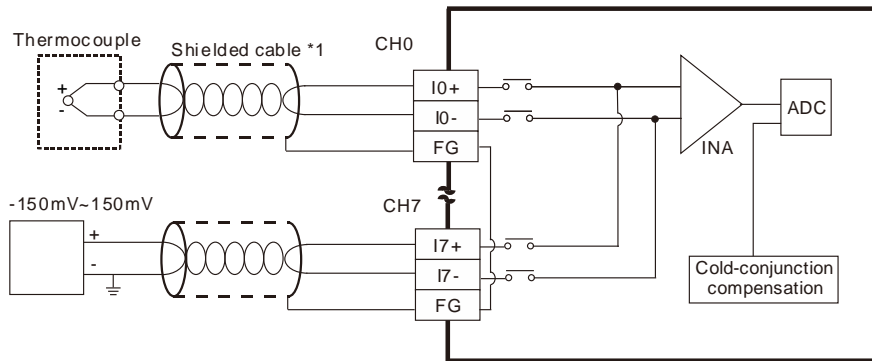

*1. The cable connected to the input terminal should be the cable or the shielded twisted pair cable which can be connected to type J, type K, type R, type S, type T, type E, or type N thermocouple, and should be kept separate from other power cables and cables which generate noise.

5

5.8 Wiring Network Modules

5.8.1 Wiring AH10DNET-5A

5.8.1.1 DeviceNet Connector

Pin	Signal	Color	Description
5	V+	Red	24 V DC
4	CAN_H	White	Signal (positive pole)
3	SHIELD	-	It is connected to a shielded cable.
2	CAN_L	Blue	Signal (negative pole)
1	V-	Black	0 V DC

The diagram shows a 5-pin DeviceNet connector. The pins are labeled 1 through 5 from bottom to top. Pin 1 is black, pin 2 is blue, pin 3 is white, pin 4 is white, and pin 5 is red. The connector is shown in a perspective view.

5.8.1.2 Connecting a Cable to the DeviceNet Connector

- Remove the 30 millimeter plastic jacket of a cable with a professional tool. Please do not damage the shielded cable when the plastic jacket is removed.
- After users remove the metallic shield and the foil, they can see two power cables (in red and black respectively), two signal cables (in blue and white respectively), and one shielded cable.
- After the metallic shield and the foil are removed, the users need to remove the plastic jackets of the power cables and the plastic jackets of the signal cables properly.

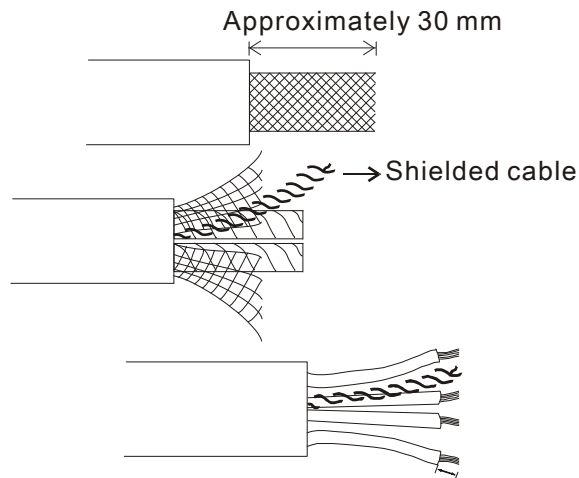

- Insert the communication cable into the holes in the connector.

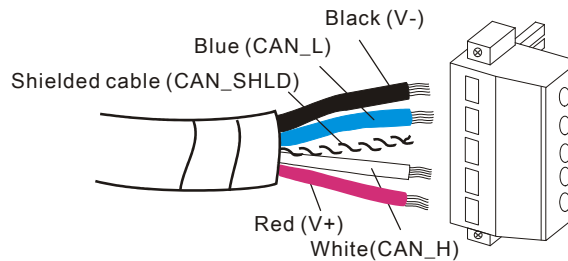

- After the communication cable is inserted into the holes in the connector, tighten the screws on the connector with a slotted screwdriver.

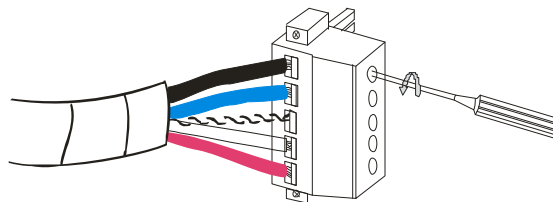

5.8.1.3 Installing the DeviceNet Connector

- After the wiring is complete, users can insert the DeviceNet connector into the interface.
- Tighten the two screws on the DeviceNet connector.

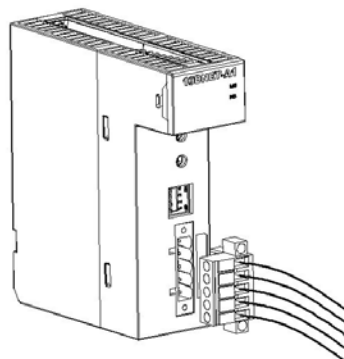

Points for attention:

- After the communication cable is kept separate from the power cable, the electromagnetic interference is reduced.
- Only after the both ends of the shielded cable are grounded can the shielded cable be brought into full

play.

5.8.2 Wiring AH10EN-5A

RJ45 communication port

Pin	Signal	Description
1	TX+	Transmitting data (positive pole)
2	TX-	Transmitting data (negative pole)
3	RX+	Receiving data (positive pole)
4	--	N/C
5	--	N/C
6	RX-	Receiving data (negative pole)
7	--	N/C
8	--	N/C

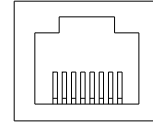

8 ← 1

5.8.3 Wiring AH10SCM-5A

RS-485/RS-422 communication port

Pin	RS-485	RS-422
1	N/C	TX+
2	N/C	TX-
3	D+	RX+
4	D-	RX-
5	SG	SG
6	N/C	SG

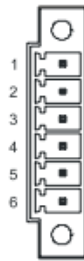

5.8.4 Wiring AH10PFBM-5A/AH10PFBS-5A

5.8.4.1 Connecting the PROFIBUS-DP Connector

- Insert the PROFIBUS-DP connector into the communication port on AH10PFBM-5A/AH10PFBS-5A. Tighten the screws on the PROFIBUS-DP connector to ensure that AH10PFBM-5A/AH10PFBS-5A is reliably connected to the PROFIBUS-DP connector.

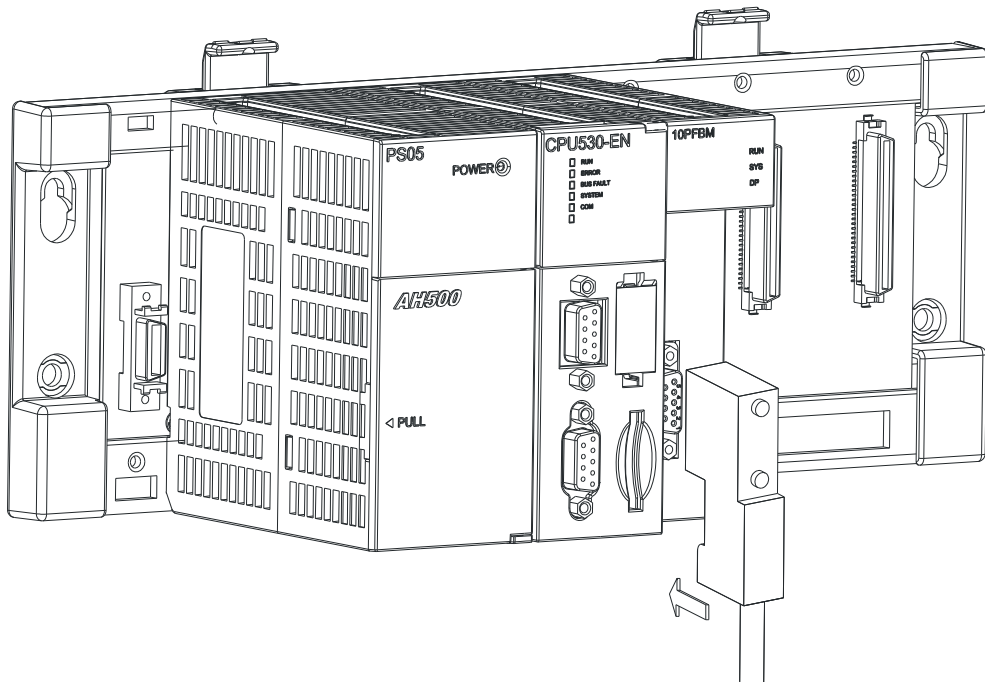

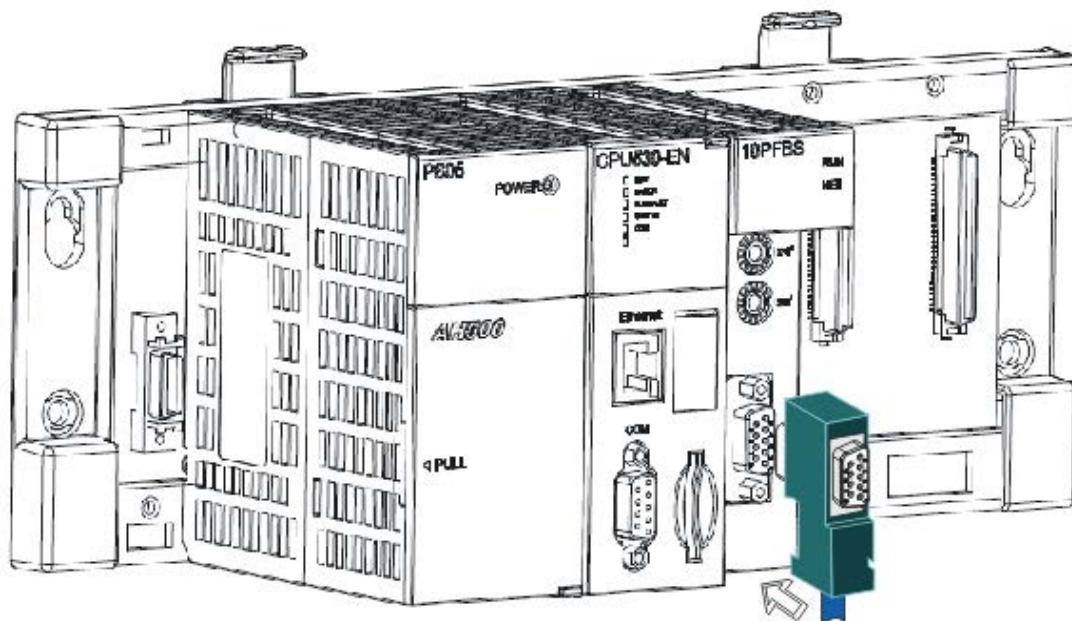

5

5.8.4.2 Definitions of the Pins in the PROFIBUS-DP Port

Pin	Definition	Description
1	--	N/C
2	--	N/C
3	RxD/TxD-P	Receiving/Sending data (P (B))
4	--	N/C
5	DGND	Data reference potential (C)
6	VP	Supplying positive voltage (5 V)
7	--	N/C
8	RxD/TxD-N	Receiving/Sending data (N (A))
9	--	N/C

5.8.4.3 Setting a PROFIBUS Node Address by the Knobs

The address knobs on AH10PFBM-5A/AH10PFBS-5A are used to set the node address of AH10PFBM-5A/AH10PFBS-5A on a PROFIBUS-DP network. They are knobs which can be turned. One knob corresponds to $x16^0$, and the other node corresponds to $x16^1$. Setting range: 0~F

Address	Definition
H'1~H'7D	Valid PROFIBUS node address
H'0 or H'7E~H'FF	Invalid PROFIBUS node address

Example: If the node address of AH10PFBM-5A/AH10PFBS-5A is 26 (decimal value), users have to turn the knob corresponding to $x16^1$ to position 1, and turn the knob corresponding to $x16^0$ to position A.
 26 (decimal value) = $1A$ (hexadecimal value) = $1 \times 16^1 + A \times 16^0$

Points for attention:

- If users set the node address of AH10PFBM-5A/AH10PFBS-5A when AH10PFBM-5A/AH10PFBS-5A is not supplied with power, they have to power AH10PFBM-5A/AH10PFBS-5A after the node address of

- AH10PFBM-5A/AH10PFBS-5A is set.
- If users change the node address of AH10PFBM-5A/AH10PFBS-5A when AH10PFBM-5A/AH10PFBS-5A is powered, the change will not take effect immediately after the node address of AH10PFBM-5A/AH10PFBS-5A is changed, and it will take effect after the users cut off the power supplied to AH10PFBM-5A/AH10PFBS-5A and then power AH10PFBM-5A/AH10PFBS-5A again.
 - To prevent the address knobs on AH10PFBM-5A/AH10PFBS-5A from being scratched, please carefully use a slotted screwdriver to rotate the address knobs on AH10PFBM-5A/AH10PFBS-5A.

5.8.5 Wiring AH10COPM-5A

5.8.5.1 CANopen Communication Connector

A CANopen connector is connected to a CANopen network. Please wire AH10COPM-5A by using the connector attached to AH10COPM-5A.

Pin	Signal	Description
5	-	Reserved
4	CAN+	CAN_H
3	SHLD	Shielded cable
2	CAN-	CAN_L
1	GND	0 V DC

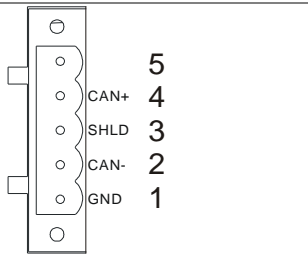

5.8.5.2 Address Knobs

The address knobs on AH10COPM-5A are used to set the node address of AH10COPM-5A on a CANopen network. Setting range: 1~7F (0 and 80~FF can not be used.)

Setting	Description
1~7F	Valid CANopen node address
0, 80 ~ FF	Invalid CANopen node address

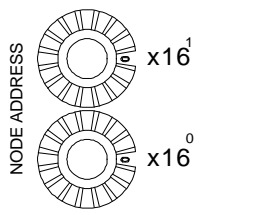

Example: If the station address of AH10COPM-5A is 16#26, users have to turn the knob corresponding to $x16^1$ to position 2, and turn the knob corresponding to $x16^0$ to position 6.

Points for attention:

- After the station address of AH10COPM-5A is changed, users have to power AH10COPM-5A again, otherwise the change will not take effect.
- To prevent the address knobs on AH10COPM-5A from being scratched, please carefully use a slotted screwdriver to rotate the address knobs on AH10COPM-5A.

5.8.5.3 Function Switch

The function switch on AH10COPM-5A is used to set the communication speed at which AH10COPM-5A is connected to a CANopen network. There is a limit on the maximum communication distance to which a communication speed corresponds.

DR 2	DR 1	DR 0	Communication speed	Maximum communication distance
OFF	OFF	OFF	10 kbps	5000 m
OFF	OFF	ON	20 kbps	2500 m
OFF	ON	OFF	50 kbps	1000 m
OFF	ON	ON	125 kbps	500 m
ON	OFF	OFF	250 kbps	250 m
ON	OFF	ON	500 kbps	100 m
ON	ON	OFF	800 kbps	50 m
ON	ON	ON	1 Mbps	25 m
IN 0				Reserved

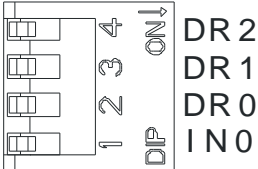

Points for attention:

- After users change the communication speed at which AH10COPM-5A is connected to a CANopen network, they have to power AH10COPM-5A again, otherwise the change will not take effect.
- To prevent the DIP switch on AH10COPM-5A from being scratched, please carefully use a slotted screwdriver to rotate the DIP switch on AH10COPM-5A.

5

5.9 Wiring Remote I/O Modules

5.9.1 Wiring AHRTU-DNET-5A

5.9.1.1 DeviceNet Connector

Pin	Signal	Color	Description
5	V+	Red	24 V DC
4	CAN_H	White	Signal (positive pole)
3	Ground	-	It is connected to a shielded cable.
2	CAN_L	Blue	Signal (negative pole)
1	V-	Black	0 V DC

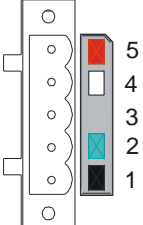

5.9.1.2 Connecting a Cable to the DeviceNet Connector

- Remove the 30 millimeter plastic jacket of a cable with a professional tool. Please do not damage the shielded cable when the plastic jacket is removed.

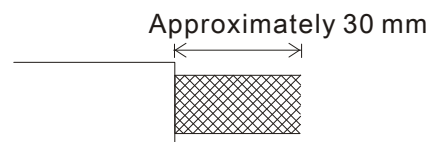

- After users remove the metallic shield and the foil, they can see two power cables (in red and black respectively), two signal cables (in blue and white respectively), and one shielded cable.

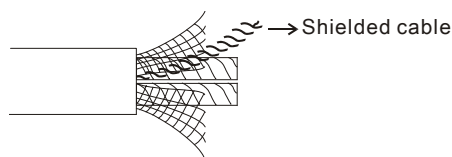

- After the metallic shield and the foil are removed, the users need to remove the plastic jackets of the power cables and the plastic jackets of the signal cables properly.

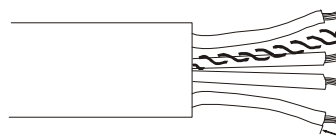

- Insert the communication cable into the holes in the connector.

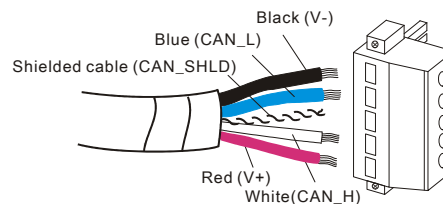

- After the communication cable is inserted into the holes in the connector, tighten the screws on the connector with a slotted screwdriver.

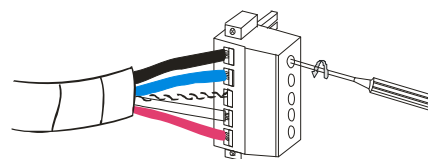

5.9.1.3 Installing the DeviceNet Connector

- After the wiring is complete, users can insert the DeviceNet connector into the interface.
- Tighten the two screws on the DeviceNet connector.

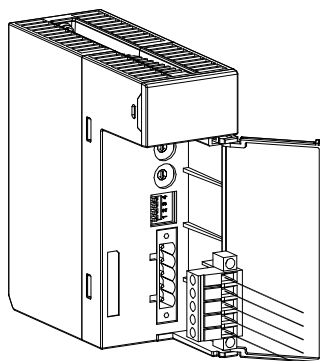

Points for attention:

- After the communication cable is kept separate from the power cable, the electromagnetic interference is reduced.
- Only after the both ends of the shielded cable are grounded can the shielded cable be brought into full play.

5.9.2 Wiring AHRTU-PFBS-5A

5.9.2.1 Connecting the PROFIBUS-DP Connector

- Insert the PROFIBUS-DP connector into the communication port on AHRTU-PFBS-5A. Tighten the screws on the PROFIBUS-DP connector to ensure that AHRTU-PFBS-5A is reliably connected to the PROFIBUS-DP connector.

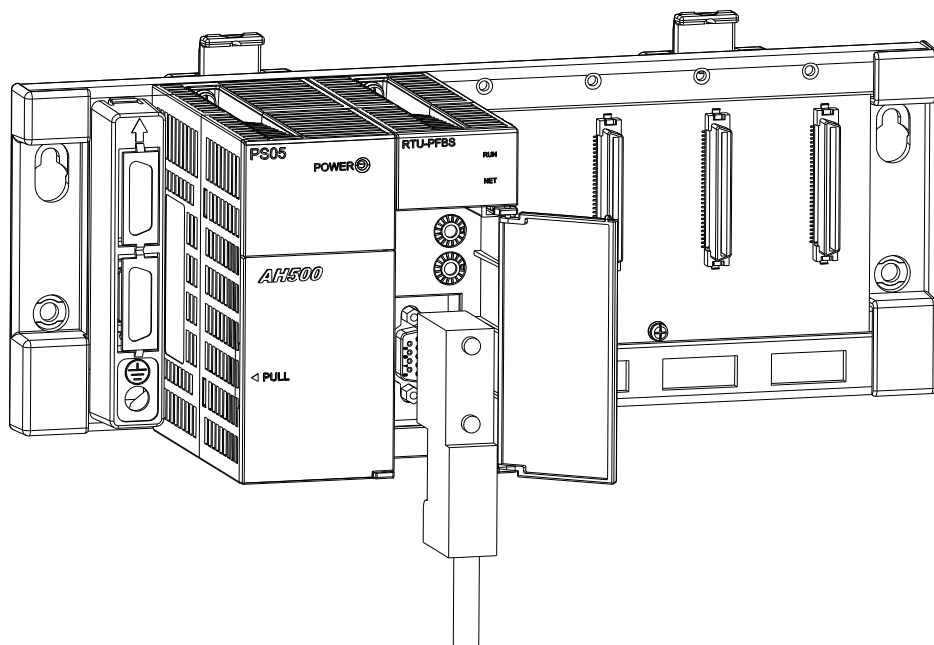

5

5.9.2.2 Definitions of the Pins in the PROFIBUS-DP Port

Pin	Definition	Description
1	--	N/C
2	--	N/C
3	RxD/TxD-P	Receiving/Sending data (P (B))
4	--	N/C
5	DGND	Data reference potential (C)
6	VP	Supplying positive voltage (5 V)
7	--	N/C
8	RxD/TxD-N	Receiving/Sending data (N (A))
9	--	N/C

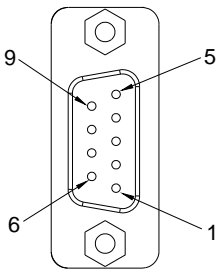

5.9.2.3 Setting a PROFIBUS Node Address by the Knobs

The address knobs on AHRTU-PFBS-5A are used to set the node address of AHRTU-PFBS-5A on a PROFIBUS-DP network. They are knobs which can be turned. One knob corresponds to $x16^0$, and the other node corresponds to $x16^1$. Setting range: 0~F

Address	Definition
H'1~H'7D	Valid PROFIBUS node address
H'0 or H'7E~H'FF	Invalid PROFIBUS node address

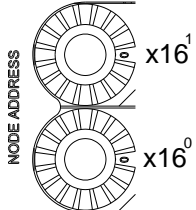

Example: If the node address of AHRTU-PFBS-5A is 26 (decimal value), users have to turn the knob

corresponding to $x16^1$ to position 1, and turn the knob corresponding to $x16^0$ to position A.
 26 (decimal value) = $1A$ (hexadecimal value) = $1 \times 16^1 + A \times 16^0$

Points for attention:

- If users set the node address of AHRTU-PFBS-5A when AHRTU-PFBS-5A is not supplied with power, they have to power AHRTU-PFBS-5A after the node address of AHRTU-PFBS-5A is set.
- If users change the node address of AHRTU-PFBS-5A when AHRTU-PFBS-5A is powered, the change will not take effect immediately after the node address of AHRTU-PFBS-5A is changed, and it will take effect after the users cut off the power supplied to AHRTU-PFBS-5A and then power AHRTU-PFBS-5A again.
- To prevent the address knobs on AHRTU-PFBS-5A from being scratched, please carefully use a slotted screwdriver to rotate the address knobs on AHRTU-PFBS-5A.

5.9.3 Wiring AHAADP01EF-5A/AHAADP02EF-5A

5.9.3.1 Connecting 100BASE-FX Fibers

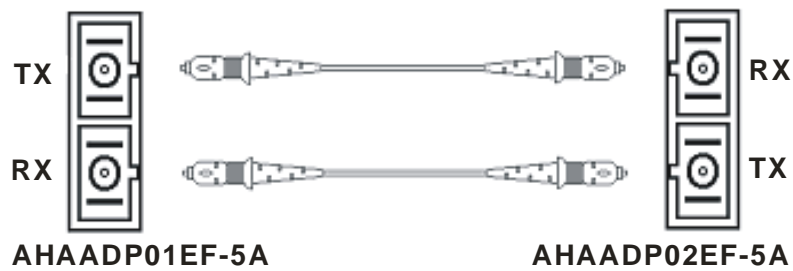

5.9.3.2 Specifications for Cables

- SC, multimode fiber, 62.5/125 μm
- SC, multimode fiber, 50/125 μm

5.9.3.3 Installing AHAADP01EF-5A/AHAADP02EF-5A on a Backplane

The connector of AHAADP01EF-5A must be connected to the lower extension port of a backplane. The connector of AHAADP02EF-5A must be connected to the upper extension port of a backplane.

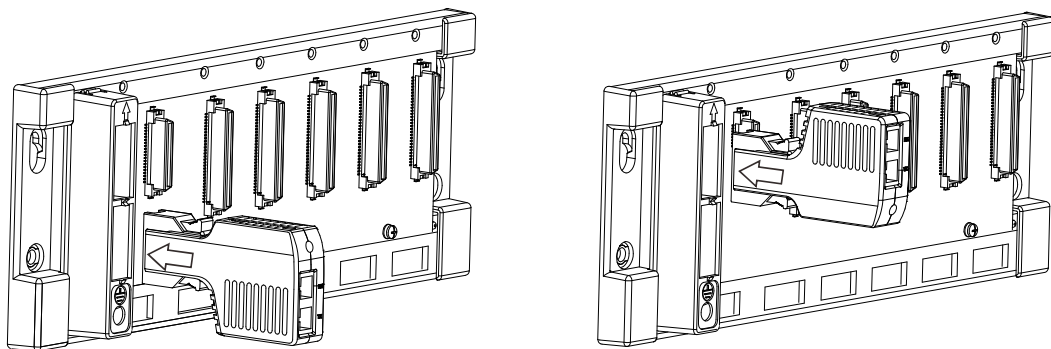

Points for attention:

- When users install AHAADP01EF-5A/AHAADP02EF-5A on a backplane, they have to make sure that AHAADP01EF-5A/AHAADP02EF-5A is connected to an extension port of the backplane correctly. (AHAADP01EF-5A must be connected to the lower extension port of the backplane, and AHAADP02EF-5A must be connected to the upper extension port of the backplane.) Otherwise, an error will occur if a CPU module connects to AHAADP01EF-5A/AHAADP02EF-5A.

5.10 Wiring Motion Control Modules

5.10.1 Specifications for Motion Control Modules

- AH02HC-5A

Item		Specifications
Number of channels		2 channels
Input signal	Input (differential input)	CH0: X0.8+, X0.8-, X0.9+, and X0.9- CH1: X0.10+, X0.10-, X0.11+, and X0.11-
	Pulse format	Pulse/Direction (one phase and one input) Counting up/Counting down (one phase and two inputs) One time the frequency of A/B-phase inputs (two phases and two inputs) Four times the frequency of A/B-phase inputs (two phases and two inputs)
	Signal level	5~24 V DC
Specifications	Maximum frequency of counting	The maximum frequency is 200 kHz.
	Range	The number of sampled pulses is in the range of -200000 to 200000. The number of accumulated pulses is in the range of -999999999 to 999999999. The number of input pulses is in the range of -2147483648 to 2147483648.
	Type	General count Circular count
RESET input	Input (differential input)	CH0: X0.0+ and X0.0- CH1: X0.1+ and X0.1-
	Signal level	5~24 V DC
	Maximum current	15 mA
Comparison output	Output type	CH0: The high-speed pulse output Y0.8 is a transistor whose collector is an open collector. CH1: The high-speed pulse output Y0.9 is a transistor whose collector is an open collector.
	Signal level	24 V DC
	Maximum current	15 mA

- AH04HC-5A

Item		Specifications
Number of channels		4 channels
Input signal	Input (differential input)	CH0: X0.8+, X0.8-, X0.9+, and X0.9- CH1: X0.10+, X0.10-, X0.11+, and X0.11- CH2: X0.12+, X0.12-, X0.13+, and X0.13- CH3: X0.14+, X0.14-, X0.15+, and X0.15-
	Pulse format	Pulse/Direction (one phase and one input) Counting up/Counting up (one phase and two inputs) One time the frequency of A/B-phase inputs (two phases and two inputs) Four times the frequency of A/B-phase inputs (two phases and two inputs)
	Signal level	5~24 V DC

Item		Specifications
Specifications	Maximum frequency of counting	The maximum frequency is 200 kHz.
	Range	The number of sampled pulses is in the range of -200000 to 200000. The number of accumulated pulses is in the range of -999999999 to 999999999. The number of input pulses is in the range of -2147483648 to 2147483648.
	Type	Linear count Circular count
RESET input	Input (differential input)	CH0: X0.0+ and X0.0- CH1: X0.1+ and X0.1- CH2: X0.2+ and X0.2- CH3: X0.3+ and X0.3-
	Signal level	5~24V DC
	Maximum current	15 mA
Comparison output	Output type	CH0: The high-speed pulse output Y0.8 is a transistor whose collector is an open collector. CH1: The high-speed pulse output Y0.9 is a transistor whose collector is an open collector. CH2: The high-speed pulse output Y0.10 is a transistor whose collector is an open collector. CH3: The high-speed pulse output Y0.11 is a transistor whose collector is an open collector.
	Signal level	24 V DC
	Maximum current	15 mA

5

● AH05PM-5A

Item		Specifications
		AH05PM-5A
Number of actual axes		2 axes
Storage		The capacity of the built-in storage is 64K steps.
Unit		Motor unit Compound unit Mechanical unit
Connection with a CPU module		Users can set the initial register involved in the data exchange in a CPU module, and the number of registers involved in the data exchange in the CPU module. Four hundred data registers at most can be involved in the data exchange.
Motor control		There are three types of pulse output modes. These modes adopt the differential output. 1. Pulse/Direction 2. Counting up/Counting down 3. A/B-phase output
Maximum speed		Single axis: 1M PPS Multi-axis interpolation: 1M PPS
Input signal	Detector	X0.0, X0.1, X0.8, X0.9, X0.12, and X0.13
Output signal	Servo output signal	Y0.0+, Y0.0-, Y0.2+, Y0.2-, Y0.1+, Y0.1-, Y0.3+, Y0.3-, Y0.8, and Y0.9
External communication port		Mini USB port
Number of basic instructions		27
Number of applied instructions		130

Item	Specifications
	AH05PM-5A
M-code	<ol style="list-style-type: none"> OX0~OX99 (motion subroutine/positioning program): M02 (The execution of the program stops. (END)) M00~M01, M03~M101, and M103~M65535: The execution of the program pauses. (WAIT) Users can use them freely.
G-code	G0 (rapid positioning), G1 (linear interpolation), G2 (circular interpolation, clockwise), G3 (circular interpolation, counterclockwise), G4 (dwell), G17 (XY plane selection), G90 (absolute programming), and G91 (incremental programming)

Description of the terminals

Terminal	Description	Response characteristic	Maximum input	
			Current	Voltage
X0.0, X0.1, X0.8, X0.9, X0.12, and X0.13	<ol style="list-style-type: none"> They are single/A/B-phase input terminals. The functions of the terminals: <ul style="list-style-type: none"> Motion control: <ul style="list-style-type: none"> ◆ X0.0 is the PG input for axis 1, and X0.1 is the PG input for axis 2. ◆ X0.12 is the DOG input for axis 1, and X0.13 is the DOG input for axis 2. ◆ X0.8 and X0.9 are for a manual pulse generator. High-speed count: <ul style="list-style-type: none"> ◆ X0.0 is the RESET input for counter 0. ◆ X0.8 is the A-phase input for counter 0, and X0.9 is the B-phase input for counter 0. High-speed comparison and catch: The terminals can function as trigger signals for high-speed catches. Interrupt input terminals 	100 kHz (*1)	15 mA	24 V
Y0.8 and Y0.9	<ol style="list-style-type: none"> The high-speed pulse output terminals are transistors whose collectors are open collectors. The functions of the terminals: <ul style="list-style-type: none"> Motion control: Y0.8 is the CLEAR output for axis 1, and Y0.9 is the CLEAR output for axis 2. High-speed comparison and catch: The high-speed comparison output terminals provide the PWM function. 	200 kHz	15 mA	24 V
Y0.0+, Y0.0-, Y0.1+, Y0.1-, Y0.2+, Y0.2-, Y0.3+, and Y0.3-	<ol style="list-style-type: none"> They are differential output terminals. The function of the terminals: <ul style="list-style-type: none"> Motion control: <ul style="list-style-type: none"> ◆ Y0.0+ and Y0.0- are the A-phase output terminals for axis 1. Y0.2+ and Y0.2- are the A-phase output terminals for axis 2. ◆ Y0.1+ and Y0.1- are the B-phase output terminals for axis 1. Y0.3+ and Y0.3- are the B-phase output terminals for axis 2. 	1 MHz	5 mA	5 V

*1. If the frequency of input signals received by an input terminal must be 200 kHz, the input terminal must be connected to a 1 k Ω (2 W) resistor in parallel.

● AH10PM-5A

Item		Specifications		
		AH10PM-5A		
Number of actual axes		6 axes		
Storage		The capacity of the built-in storage is 64K steps.		
Unit		Motor unit	Compound unit	Mechanical unit
Connection with a CPU module		Users can set the initial register involved in the data exchange in a CPU module, and the number of registers involved in the data exchange in the CPU module. Four hundred data registers at most can be involved in the data exchange.		
Motor control		There are three types of pulse output modes. These modes adopt the differential output. <ol style="list-style-type: none"> Pulse/Direction Counting up/Counting down A/B-phase output 		
Maximum speed		Single axis: 1M PPS Multi-axis interpolation: 1M PPS		
Input signal	Operating switch	STOP/RUN (automatic/manual switch)		
	Detector	X0.8, X0.9, X0.10, X0.11, X0.12, X0.13, X0.14, X0.15, X0.0+, X0.0-, X0.1+, X0.1-, X0.2+, X0.2-, X0.3+, and X0.3-		
Output signal	Servo output signal	Y0.0+, Y0.0-, Y0.2+, Y0.2-, Y0.4+, Y0.4-, Y0.6+, Y0.6-, Y0.1+, Y0.1-, Y0.3+, Y0.3-, Y0.5+, Y0.5-, Y0.7+, Y0.7-, Y0.8, Y0.9, Y0.10, and Y0.11		
External communication port		Mini USB port Ethernet port		
Expansion storage device		Mini SD card The maximum capacity is 32 GB.		
Number of basic instructions		27		
Number of applied instructions		130		
M-code		<ol style="list-style-type: none"> OX0~OX99 (motion subroutine/positioning program): M02 (The execution of the program stops. (END)) M00~M01, M03~M101, and M103~M65535: The execution of the program pauses. (WAIT) Users can use them freely. 		
G-code		G0 (rapid positioning), G1 (linear interpolation), G2 (circular interpolation, clockwise), G3 (circular interpolation, counterclockwise), G4 (dwell), G17 (XY plane selection), G18 (ZX plane selection), G19 (YZ plane selection), G90 (absolute programming), and G91 (incremental programming)		

Description of the terminals

Terminal	Description	Response characteristic	Maximum input	
			Current	Voltage
X0.0+, X0.0-, X0.1+, X0.1-, X0.2+, X0.2-, X0.3+, and X0.3-	<ol style="list-style-type: none"> They are differential input terminals. The functions of the terminals: <ul style="list-style-type: none"> ● Motion control: They are the PG input terminals for axis 1~axis 4. ● High-speed counter: X0.0+ and X0.0- are the RESET input terminals for counter 0. X0.1+ and X0.1- are the RESET input terminals for counter 1. X0.2+ and X0.2- are the RESET input terminals for counter 2 and counter 4. X0.3+ and X0.3- are the RESET input terminals for counter 3 and counter 5. ● High-speed comparison and catch: The terminals can function as trigger signals for high-speed catches. ● Interrupt input terminals 	200 kHz	15 mA	5~24 V
X0.8 and X0.9	<ol style="list-style-type: none"> They are single/A/B-phase input terminals. The functions of the terminals: <ul style="list-style-type: none"> ● Motion control: The terminals are for a manual pulse generator. ● High-speed count: <ul style="list-style-type: none"> ◆ The terminals are for counter 0. ◆ X0.8 is the A-phase input for counter 0, and X0.9 is the B-phase input for counter 0. ● High-speed comparison and catch: The terminals can function as trigger signals for high-speed catches. ● Interrupt input terminals 	100 kHz (*1)	15 mA	24 V
X0.10, X0.11, X0.12, X0.13, X0.14, and X0.15	<ol style="list-style-type: none"> They are single/A/B-phase input terminals. The functions of the terminals: <ul style="list-style-type: none"> ● Motion control: They are the DOG input terminals for axis 1~axis 6. ● High-speed counter: <ul style="list-style-type: none"> ◆ The terminals are for counter 1~counter 5. ◆ X0.10 is the A-phase input for counter 1, X0.12 is the A-phase input for counter 2 and counter 4, and X0.14 is the A-phase input for counter 3 and counter 5. ◆ X0.11 is the B-phase input for counter 1, X0.13 is the B-phase input for counter 2 and counter 4, and X0.15 is the B-phase input for counter 3 and counter 5. ● High-speed comparison and catch: The terminals can function as trigger signals for high-speed catches. ● Interrupt input terminals 	100 kHz (*1)	15 mA	24 V

Terminal	Description	Response characteristic	Maximum input	
			Current	Voltage
Y0.8, Y0.9, Y0.10, and Y0.11	<ol style="list-style-type: none"> The high-speed pulse output terminals are transistors whose collectors are open collectors. The functions of the terminals: <ul style="list-style-type: none"> ● Motion control: <ul style="list-style-type: none"> ◆ The terminals are the CLEAR output terminals for axis 1~axis 4, and provide the PWM function. ◆ Y0.8 and Y0.9 are for axis 5. Y0.10 and Y0.11 are for axis 6. Y0.8 is the A-phase output for axis 5, and Y0.10 is the A-phase output for axis 6. Y0.9 is the B-phase output for axis 5, and Y0.11 is the B-phase output for axis 6. ● High-speed comparison and catch: The terminals can function as high-speed comparison output terminals. 	200 kHz	15 mA	24 V
Y0.0+, Y0.0-, Y0.1+, Y0.1-, Y0.2+, Y0.2-, Y0.3+, Y0.3-, Y0.4+, Y0.4-, Y0.5+, Y0.5-, Y0.6+, Y0.6-, Y0.7+, and Y0.7-	<ol style="list-style-type: none"> They are differential output terminals. The function of the terminals: <ul style="list-style-type: none"> ● Motion control: <ul style="list-style-type: none"> ◆ The terminals are for axis 1~axis 4. ◆ Y0.0+ and Y0.0- are the A-phase output terminals for axis 1. Y0.2+ and Y0.2- are the A-phase output terminals for axis 2. Y0.4+ and Y0.4- are the A-phase output terminals for axis 3. Y0.6+ and Y0.6- are the A-phase output terminals for axis 4. ◆ Y0.1+ and Y0.1- are the B-phase output terminals for axis 1. Y0.3+ and Y0.3- are the B-phase output terminals for axis 2. Y0.5+ and Y0.5- are the B-phase output terminals for axis 3. Y0.7+ and Y0.7- are the B-phase output terminals for axis 4. ◆ Y0.0+ and Y0.0- are the CLEAR output terminals for axis 5. Y0.1+ and Y0.1- are the CLEAR output terminals for axis 6. 	1 MHz	5 mA	5 V

*1. If the frequency of input signals received by an input terminal must be 200 kHz, the input terminal must be connected to a 1 kΩ (2 W) resistor in parallel.

● AH15PM-5A

Item		AH15PM-5A
Number of actual axes		4 axes
Storage		The capacity of the built-in storage is 64K steps.
Unit		Motor unit Compound unit Mechanical unit
Connection with a CPU module		Users can set the initial register involved in the data exchange in a CPU module, and the number of registers involved in the data exchange in the CPU module. Four hundred data registers at most can be involved in the data exchange.
Motor control		There are three types of pulse output modes. These modes adopt the differential output. 1. Pulse/Direction 2. Counting up/Counting down 3. A/B-phase output
Maximum speed		Single axis: 1M PPS Multi-axis interpolation: 1M PPS
Input signal	Operating switch	STOP/RUN (automatic/manual switch)
	Detector	X0.0+, X0.0-, X0.1+, X0.1-, X0.2+, X0.2-, X0.3+, and X0.3-, X0.4, X0.5, X0.6, X0.7, X0.10, X0.11, X0.12, X0.13, X0.14, X0.15, X1.0, X1.1
Output signal	Servo output signal	Y0.0+, Y0.0-, Y0.2+, Y0.2-, Y0.4+, Y0.4-, Y0.6+, Y0.6-, Y0.1+, Y0.1-, Y0.3+, Y0.3-, Y0.5+, Y0.5-, Y0.7+, Y0.7-, Y0.8, Y0.9, Y0.10, and Y0.11
External communication port		Mini USB port Ethernet port
Expansion storage device		Mini SD card The maximum capacity is 32 GB.
Number of basic instructions		27
Number of applied instructions		130
M-code		1. OX0~OX99 (motion subroutine/positioning program): M02 (The execution of the program stops. (END)) 2. M00~M01, M03~M101, and M103~M65535: The execution of the program pauses. (WAIT) Users can use them freely.
G-code		G0 (rapid positioning), G1 (linear interpolation), G2 (circular interpolation, clockwise), G3 (circular interpolation, counterclockwise), G4 (dwell), G17 (XY plane selection), G18 (ZX plane selection), G19 (YZ plane selection), G90 (absolute programming), and G91 (incremental programming)

Description of the terminals

Terminal	Description	Response characteristic	Maximum input	
			Current	Voltage
X0.0+, X0.0-, X0.1+, X0.1-, X0.2+, X0.2-, X0.3+, and X0.3-	1. They are differential input terminals. 2. The functions of the terminals: <ul style="list-style-type: none"> ● Motion control: They are the PG input terminals for axis 1~axis 4. ● High-speed counter: X0.0+ and X0.0- are the RESET input terminals for counter 0. X0.1+ and X0.1- are the RESET input terminals for counter 1. X0.2+ and X0.2- are the RESET input terminals for counter 2 and counter 4. X0.3+ and X0.3- are the RESET input terminals for counter 3 and counter 5. ● High-speed comparison and catch: The terminals can function as trigger signals for high-speed catches. ● Interrupt input terminals 	200 kHz	15 mA	5~24 V
X0.4, X0.5, X0.6, and X0.7	1. They are single/A/B-phase input terminals. 2. The functions of the terminals: <ul style="list-style-type: none"> ● Motion control: They are the DOG input terminals for axis 1~axis 4. 	100 kHz (*1)	15 mA	24 V
X0.8+, X0.8-, X0.9+, and X0.9-	1. They are differential input terminals. 2. The functions of the terminals: <ul style="list-style-type: none"> ● Motion control: The terminals are for a manual pulse generator. ● High-speed count: <ul style="list-style-type: none"> ◆ The terminals are for counter 0. ◆ X0.8+ and X0.8- are the A-phase input terminals for counter 0, and X0.9+ and X0.9- are the B-phase input terminals for counter 0. ● High-speed comparison and catch: The terminals can function as trigger signals for high-speed catches. ● Interrupt input terminals 	200 kHz	15 mA	5~24 V

Terminal	Description	Response characteristic	Maximum input	
			Current	Voltage
X0.10, X0.11, X0.12, X0.13, X0.14, X0.15, X1.0, and X1.1	<ol style="list-style-type: none"> 1 They are single/A/B-phase input terminals. 2 The functions of the terminals: <ul style="list-style-type: none"> ● Motion control: X0.10 is LSP0, X0.11 is LSN0, X0.12 is LSP1, X0.13 is LSN1, X0.14 is LSP2, X0.15 is LSN2, X1.0 is LSP3, and X1.1 is LSN3. ● High-speed count: <ul style="list-style-type: none"> ◆ The terminals are for counter 1~counter 5. ◆ X0.10 is the A-phase input for counter 1. X0.12 is the A-phase input for counter 2 and counter 4. X0.14 is the A-phase input for counter 3 and counter 5. ◆ X0.11 is the B-phase input for counter 1. X0.13 is the B-phase input for counter 2 and counter 4. X0.15 is the B-phase input for counter 3 and counter 5. ● High-speed comparison and catch: The terminals can function as trigger signals for high-speed catches. ● Interrupt input terminals: X0.10~X0.15 	100 kHz (*1)	15 mA	24 V
X1.2, X1.3, X1.4, and X1.5	<ol style="list-style-type: none"> 1. They are single/A/B-phase input terminals. 	100 kHz (*1)	15 mA	24 V
Y0.8, Y0.9, Y0.10, and Y0.11	<ol style="list-style-type: none"> 1. The high-speed pulse output terminals are transistors whose collectors are open collector. 2. The function of the terminals: <ul style="list-style-type: none"> ● Motion control: The terminals are the CLEAR output terminals for axis 1~axis 4. ● High-speed comparison and catch: The terminals can function as high-speed comparison output terminals. 	200 kHz	15 mA	24 V

Terminal	Description	Response characteristic	Maximum input	
			Current	Voltage
Y0.0+, Y0.0-, Y0.1+, Y0.1-, Y0.2+, Y0.2-, Y0.3+, Y0.3-, Y0.4+, Y0.4-, Y0.5+, Y0.5-, Y0.6+, Y0.6-, Y0.7+, and Y0.7-	1. They are differential output terminals. 2. The function of the terminals: <ul style="list-style-type: none"> ● Motion control: <ul style="list-style-type: none"> ◆ The terminals are for axis 1~axis 4. ◆ Y0.0+ and Y0.0- are the A-phase output terminals for axis 1. Y0.2+ and Y0.2- are the A-phase the output terminals for axis 2. Y0.4+ and Y0.4- are the A-phase output terminals for axis 3. Y0.6+ and Y0.6- are the A-phase output terminals for axis 4. ◆ Y0.1+ and Y0.1- are the B-phase output terminals for axis 1. Y0.3+ and Y0.3- are the B-phase output terminals for axis 2. Y0.5+ and Y0.5- are the B-phase output terminals for axis 3. Y0.7+ and Y0.7- are the B-phase output terminals for axis 4. ◆ Y0.0+ and Y0.0- are the CLEAR output terminals for axis 5. Y0.1+ and Y0.1- are the CLEAR output terminals for axis 6. 	1 MHz	5 mA	5 V

*1. If the frequency of input signals received by an input terminal must be 200 kHz, the input terminal must be connected to a 1 kΩ (2 W) resistor in parallel.

● AH20MC-5A

Item	Specifications		
	AH20MC-5A		
Number of actual axes	12 axes		
Storage	The capacity of the built-in storage is 64K steps.		
Unit	Motor unit	Compound unit	Mechanical unit
Connection with a CPU module	Users can set the initial register involved in the data exchange in a CPU module, and the number of registers involved in the data exchange in the CPU module. Four hundred data registers at most can be involved in the data exchange.		
Motor control	Delta high-speed motion control system DMCNET (Delta Motion Control Network) The response time is one millisecond.		
Maximum speed	Single axis: 1M PPS Two-axis interpolation: 1M PPS		
Input signal	Operating switch	STOP/RUN (automatic/manual switch)	
	Detector	X0.10+, X0.10-, X0.11+, X0.11-, X0.12+, X0.12-, X0.13+, X0.13-, X0.14+, X0.14-, X0.15+, X0.15, X0.0+, X0.0-, X0.1+, X0.1-, X0.2+, X0.2-, X0.3+, X0.3-	
Output signal	Servo output signal	Y0.8, Y0.9, Y0.10, Y0.11	
External communication port	Mini USB port Ethernet port DMCNET port		
Expansion storage device	Mini SD card The maximum capacity is 32 GB.		
Number of basic instructions	27		

Item	Specifications
	AH20MC-5A
Number of applied instructions	130
M-code	<ul style="list-style-type: none"> OX0~OX99 (motion subroutine/positioning program): M02 (The execution of the program stops. (END)) M00~M01, M03~M101, and M103~M65535: The execution of the program pauses. (WAIT) Users can use them freely.
G-code	G0 (rapid positioning), G1 (linear interpolation), G2 (circular interpolation, clockwise), G3 (circular interpolation, counterclockwise), G4 (dwell), G17 (XY plane selection), G18 (ZX plane selection), G19 (YZ plane selection), G90 (absolute programming), and G91 (incremental programming)

Description of the terminals

Terminal	Description	Response characteristic	Maximum input	
			Current	Voltage
X0.0+, X0.0-, X0.1+, X0.1-, X0.2+, X0.2-, X0.3+, and X0.3-	<ol style="list-style-type: none"> They are differential input terminals. The functions of the terminals: <ul style="list-style-type: none"> High-speed count: <ul style="list-style-type: none"> The terminals are the RESET input terminals for counter 0~counter 5. X0.0+ and X0.0- are for counter 0. X0.1+ and X0.1- are for counter 1. X0.2+ and X0.2- are for counter 2 and counter 4. X0.3+ and X0.3- are for counter 3 and counter 5. High-speed comparison and catch: The terminals can function as trigger signals for high-speed catches. Interrupt input terminals 	200 kHz	15 mA	5~24 V
X0.8+, X0.8-, X0.9+, and X0.9-	<ol style="list-style-type: none"> They are differential input terminals. The functions of the terminals: <ul style="list-style-type: none"> Motion control: The terminals are for a manual pulse generator. High-speed count: <ul style="list-style-type: none"> The terminals are for counter 0. X0.8+ and X0.8- are the A-phase input terminals for counter 0. X0.9+ and X0.9- are the B-phase input terminals for counter 0. High-speed comparison and catch: The terminals can function as trigger signals for high-speed catches. Interrupt input terminals 	200 kHz	15 mA	5~24 V

Terminal	Description	Response characteristic	Maximum input	
			Current	Voltage
X0.10+, X0.10-, X0.11+, X0.11-, X0.12+, X0.12-, X0.13+, X0.13, X0.14+, X0.14-, X0.15+, and X0.15-	<ol style="list-style-type: none"> They are differential input terminals. The functions of the terminals: <ul style="list-style-type: none"> High-speed count: <ul style="list-style-type: none"> The terminals are for counter 1~counter 5. X0.10+ and X0.10- are the A-phase input terminals for counter 1. X0.12+ and X0.12- are the A-phase input terminals for counter 2 and counter 4. X0.14+ and X0.14- are the A-phase input terminals for counter 3 and counter 5. X0.11+ and X0.11- are the B-phase input terminals for counter 1. X0.13+ and X0.13- are the B-phase input terminals for counter 2 and counter 4. X0.15+ and X0.15- are the B-phase input terminals for counter 3 and counter 5. High-speed comparison and catch: The terminals can function as trigger signals for high-speed catches. Interrupt input terminals 	200 kHz	15 mA	5~24 V
Y0.8, Y0.9, Y0.10, and Y0.11	<ol style="list-style-type: none"> The high-speed pulse output terminals are transistors whose collectors are open collectors. The function of the terminals: <ul style="list-style-type: none"> High-speed comparison and catch: The terminals can function as high-speed comparison output terminals. 	200 kHz	15 mA	24 V

5.10.2 I/O Extension Cables and External Terminal Modules

A connector for a motion control module connects an I/O extension cable to an external terminal module. Users can install wires on the input and output terminal blocks in the external terminal module.

- I/O extension cable DVPACAB7D10/DVPACAB7E10
DVPACAB7D10 is a 36-pin I/O extension cable for AH04HC-5A and AH20MC-5A.
DVPACAB7E10 is a 50-pin I/O extension cable for AH10PM-5A.

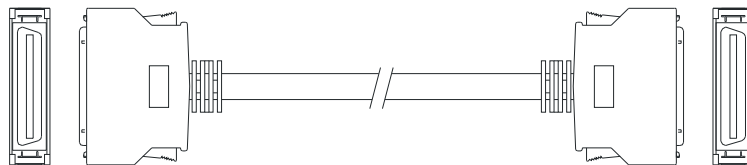

2. External terminal module for AH04HC-5A and AH20MC-5A: DVPAETB-IO16C

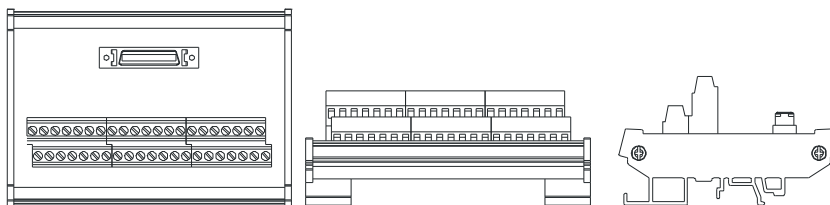

C3	C2	C1	C0	N/C	N/C	X0.3-	X0.15-	X0.14-	X0.2-	X0.13-	X0.12-	X0.1-	X0.11-	X0.10-	X0.0-	X0.9-	X0.8-	24G	24G	FE
Y0.11	Y0.10	Y0.9	Y0.8	N/C	N/C	X0.3+	X0.15+	X0.14+	X0.2+	X0.13+	X0.12+	X0.1+	X0.11+	X0.10+	X0.0+	X0.9+	X0.8+	N/C	24V	24V

3. External terminal module for AH10PM-5A: DVPAETB-IO24C

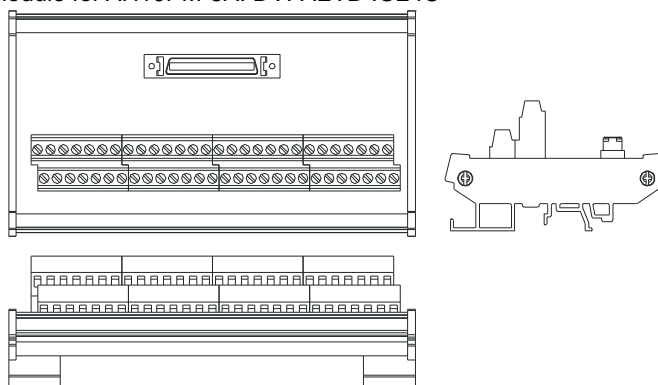

1st from the upper left	C3	C2	C1	C0	N/C	Y0.7-	Y0.6-	Y0.5-	Y0.4-	Y0.3-	Y0.2-	Y0.1-	Y0.0-	N/C
15th from the upper left	N/C	X0.15	X0.13	X0.11	X0.9	N/C	N/C	X0.3-	X0.2-	X0.1-	X0.0-	24G	24G	FE
1st from the lower left	Y0.11	Y0.10	Y0.9	Y0.8	N/C	Y0.7+	Y0.6+	Y0.5+	Y0.4+	Y0.3+	Y0.2+	Y0.1+	Y0.0+	N/C
15th from the lower left	S/S	X0.14	X0.12	X0.10	X0.8	N/C	N/C	X0.3+	X0.2+	X0.1+	X0.0+	N/C	24V	24V

5

4. External terminal module for AH15PM-5A: DVPAETB-IO34C

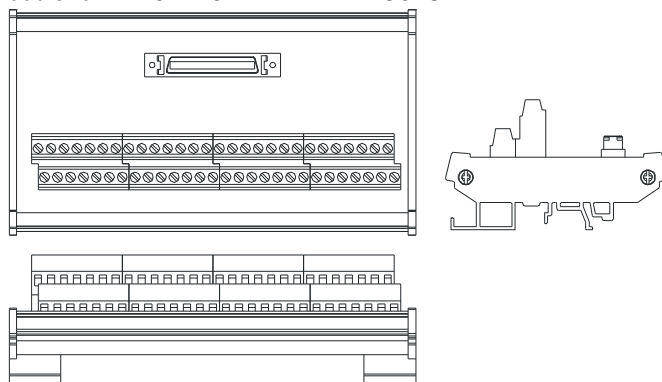

1 st from the upper left	Y0.11	Y0.9	COM	Y0.7-	Y0.6-	Y0.5-	Y0.4-	Y0.3-	Y0.2-	Y0.1-	Y0.0-	X1.5	X1.3	X1.1
15 th from the upper left	X0.15	X0.13	X0.11	X0.9-	X0.8-	X0.7	X0.5	X0.3-	X0.2-	X0.1-	X0.0-	24G	24G	FE
1 st from the lower left	Y0.10	Y0.8	Y0.7+	Y0.6+	Y0.5+	Y0.4+	Y0.3+	Y0.2+	Y0.1+	Y0.0+	S/S	Y1.4	Y1.2	Y1.0
15 th from the lower left	X0.14	X0.12	X0.10	X0.9+	X0.8+	X0.6	X0.4	X0.3+	X0.2+	X0.1+	X0.0+	N/C	24V	24V

5.10.3 Wiring AH02HC-5A and AH04HC-5A

- External devices for AH02HC-5A

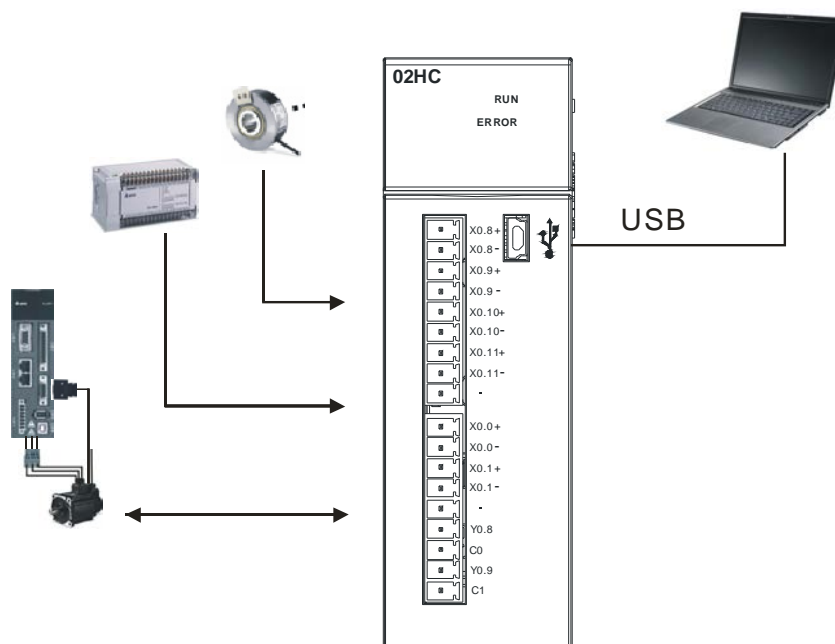

● Terminals on AH02HC-5A

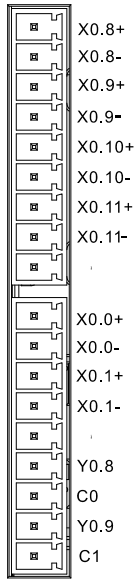

Terminal	Function	Terminal	Function
	Count		Count
X0.8+	CntA0+	X0.0+	Rst0+
X0.8-	CntA0-	X0.0-	Rst0-
X0.9+	CntB0+	X0.1+	Rst1+
X0.9-	CntB0-	X0.1-	Rst1-
X0.10+	CntA1+	Y0.8	Out0
X0.10-	CntA1-	C0	COM0
X0.11+	CntB1+	Y0.9	Out1
X0.11-	CntB1-	C1	COM1

● External devices for AH04HC-5A

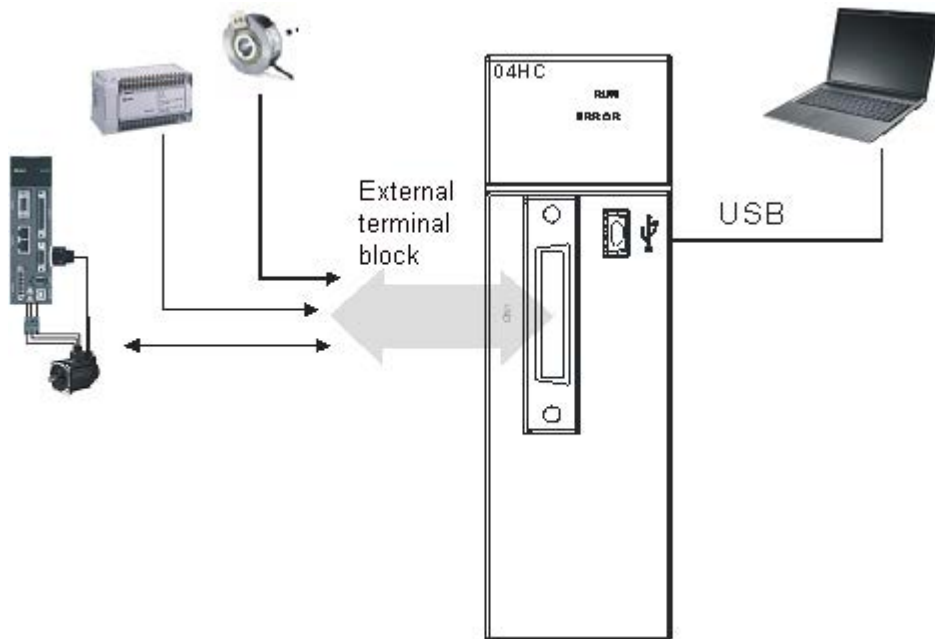

5

- Connector on AH04HC-5A

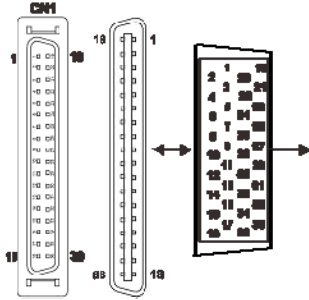

Pin	Terminal	Function	Count	Pin	Terminal	Function	Count
1	C3	COM3		19	Y0.11	Out3	
2	C2	COM2		20	Y0.10	Out2	
3	C1	COM1		21	Y0.9	Out1	
4	C0	COM0		22	Y0.8	Out0	
5	-	-		23	-	-	
6	-	-		24	-	-	
7	X0.3-	Rst3-		25	X0.3+	Rst3+	
8	X0.15-	CntB3-		26	X0.15+	CntB3+	
9	X0.14-	CntA3-		27	X0.14+	CntA3+	
10	X0.2-	Rst2-		28	X0.2+	Rst2+	
11	X0.13-	CntB2-		29	X0.13+	CntB2+	
12	X0.12-	CntA2-		30	X0.12+	CntA2+	
13	X0.1-	Rst1-		31	X0.1+	Rst1+	
14	X0.11-	CntB1-		32	X0.11+	CntB1+	
15	X0.10-	CntA1-		33	X0.10+	CntA1+	
16	X0.0-	Rst0-		34	X0.0+	Rst0+	
17	X0.9-	CntB0-		35	X0.9+	CntB0+	
18	X0.8-	CntA0-		36	X0.8+	CntA0+	

5.10.3.1 External Wiring

1. A PNP encoder is used.
PNP encoder

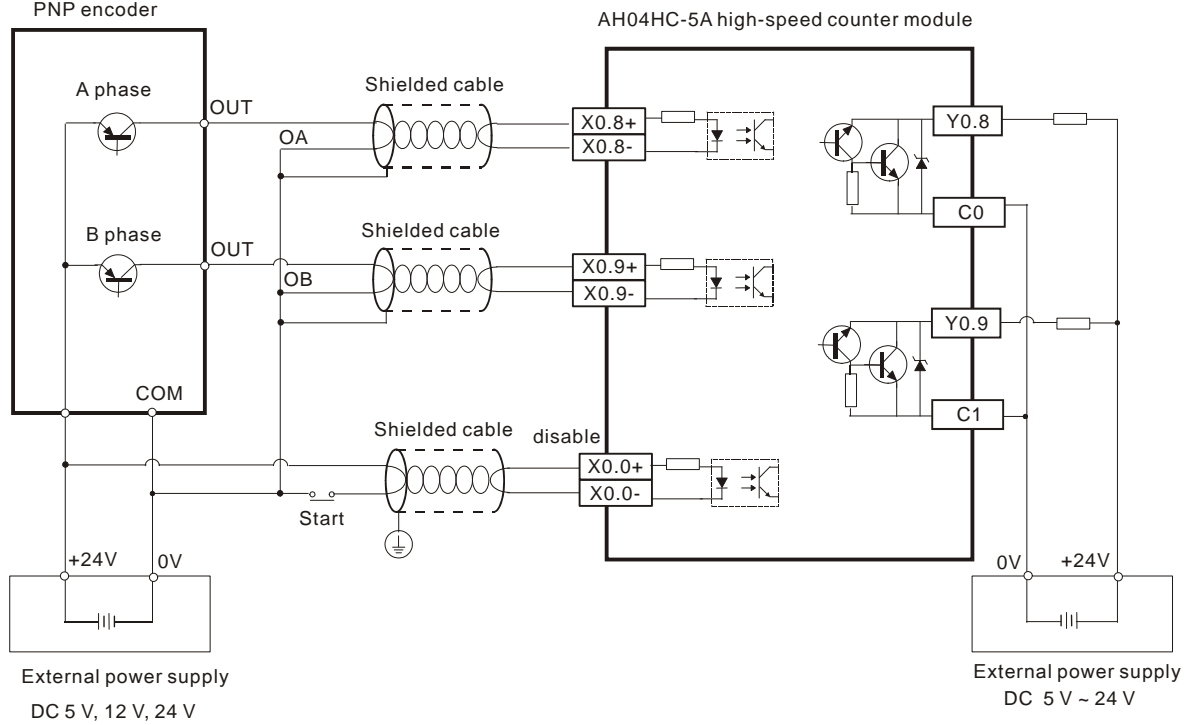

2. An NPN encoder is used.

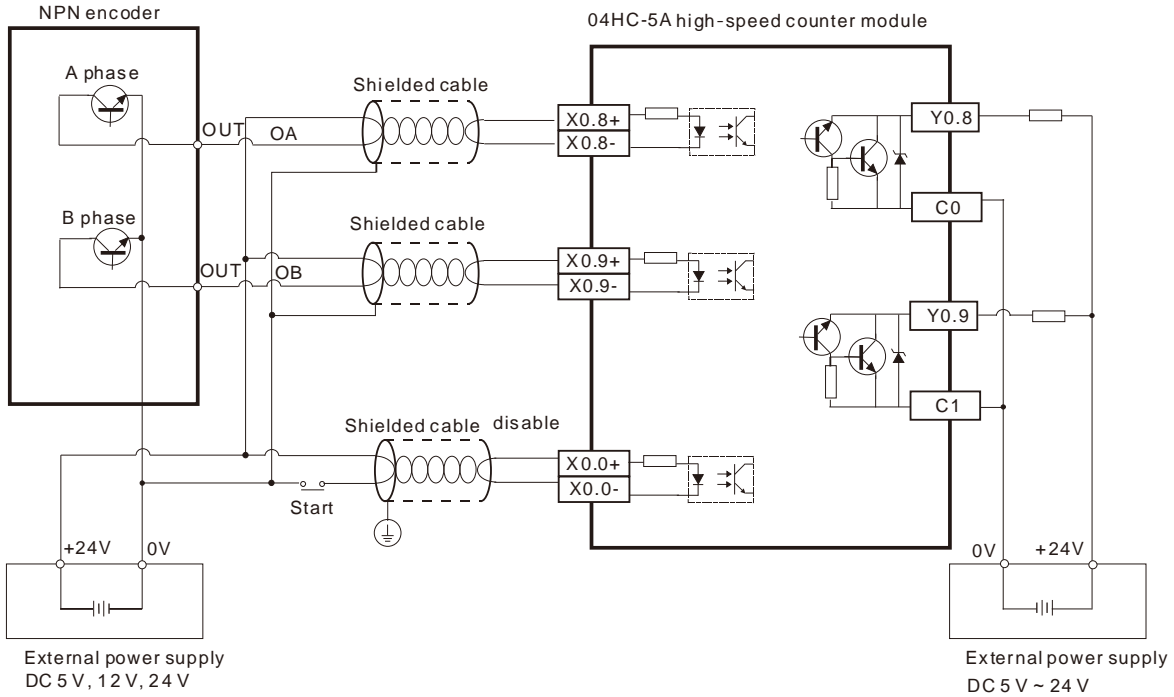

5

5.10.3.2 Wiring the Differential Input Terminals

The direct-current signals ranging in voltage from 5 V to 24 V can pass through the high-speed input terminals X0.0+~X0.1+, X0.0~-X0.1-, X0.8+~X0.11+, and X0.8~-X0.11- on AH02HC-5A, and the high-speed input terminals X0.0+~X0.3+, X0.0~-X0.3-, X0.8+~X0.15+, and X0.8~-X0.15- on AH04HC-5A. The frequency of input signals can be up to 200 kHz. These high-speed input terminals are connected to a differential (two-wire) line driver.

- Wiring differential input terminals (The wiring below is used for high speed and high noise.)

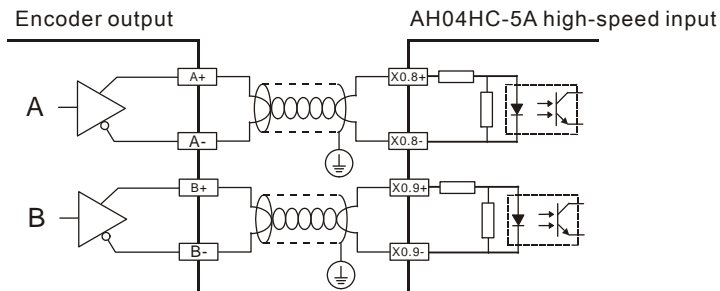

5.10.3.3 Transistor Output Circuit

AH04HC-5A

①	Direct-current power supply	②	Emergency stop	③	Fuse
---	-----------------------------	---	----------------	---	------

The output terminals of a transistor module are open-collector output terminals. If Y0.8 is a pulse train output terminal of a transistor module, the output current passing through its output pull-up resistor must be greater than 0.1 A to ensure that the transistor module operates normally. A relay or a solenoid valve is used as a DC load. A diode is connected in parallel to absorb the surge voltage which occurs when the load is OFF.

④

D: 1N4001 diode

A bulb (incandescent lamp) is used as a DC load. A thermistor is connected in series to absorb the surge current which occurs when the load is ON.

⑤

NTC: 10Ω

Y0.9 can not be connected to a power supply directly. It must be connected to a load.

AH04HC-5A

5

⑥ Mutually exclusive output: For example, Y0.10 controls the clockwise rotation of the motor, and Y0.11 controls the counterclockwise rotation of the motor. The interlock circuit which is formed, and the program in the PLC ensure that there are protective measures if an abnormal condition occurs.

5.10.4 Wiring AH05PM-5A, AH10PM-5A, and AH15PM-5A

- External devices for AH05PM-5A

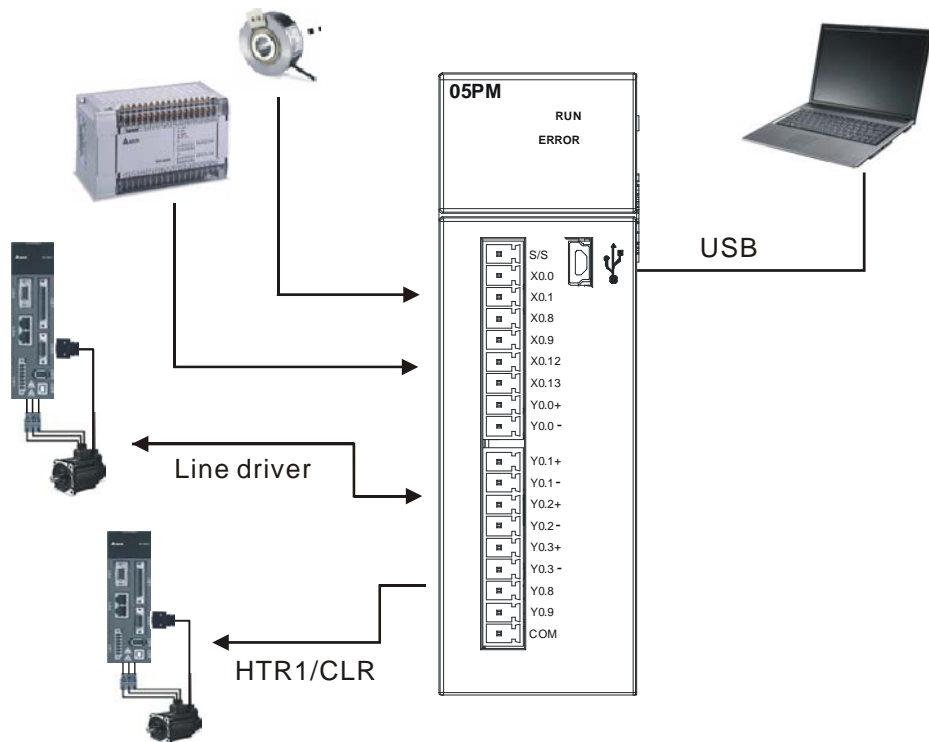

5

- Terminals on AH05PM-5A

Terminal	Function		Terminal	Function	
	Pulse	Count		Pulse	Count
S/S	S/S	S/S	Y0.1+	B0+	-
X0.0	PG0	Rst0	Y0.1-	B0-	-
X0.1	PG1	-	Y0.2+	A1+	-
X0.8	MPGA	CntA0	Y0.2-	A1-	-
X0.9	MPGB	CntB0	Y0.3+	B1+	-
X0.12	DOG0	-	Y0.3-	B1-	-
X0.13	DOG1	-	Y0.8	CLR0	-
Y0.0+	A0+	-	Y0.9	CLR1	-
Y0.0-	A0-	-	COM	-	-

● External devices for AH10PM-5A

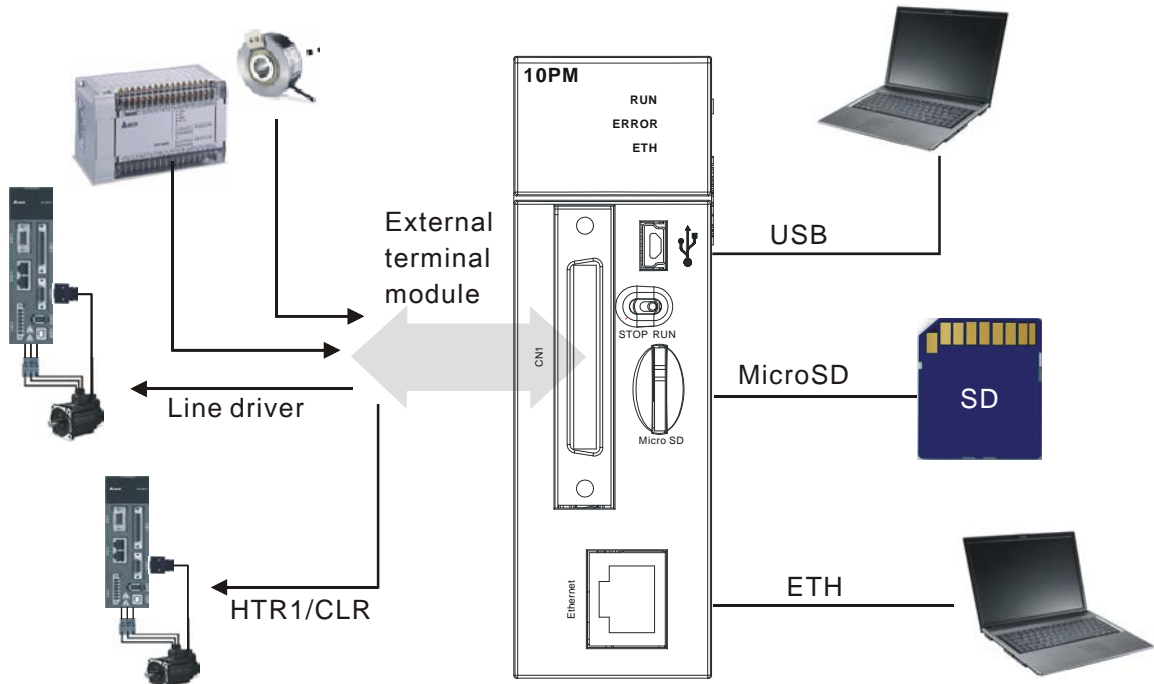

● Connector on AH10PM-5A

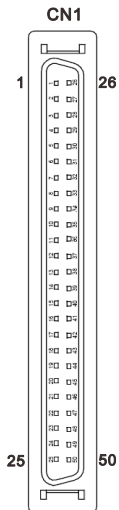

Pin	Terminal	Function		Pin	Terminal	Function	
		Pulse	Count			Pulse	Count
1	C3	COM3	-	26	Y0.11	CLR3/B5	-
2	C2	COM2	-	27	Y0.10	CLR2/A5	-
3	C1	COM1	-	28	Y0.9	CLR1/B4	-
4	C0	COM0	-	29	Y0.8	CLR0/A4	-
5	NC	-	-	30	NC	-	-
6	Y0.7-	B3-	-	31	Y0.7+	B3+	-
7	Y0.6-	A3-	-	32	Y0.6+	A3+	-
8	Y0.5-	B2-	-	33	Y0.5+	B2+	-
9	Y0.4-	A2-	-	34	Y0.4+	A2+	-
10	Y0.3-	B1-	-	35	Y0.3+	B1+	-
11	Y0.2-	A1-	-	36	Y0.2+	A1+	-
12	Y0.1-	B0-/CLR5-	-	37	Y0.1+	B0+/CLR5+	-
13	Y0.0-	A0-/CLR4-	-	38	Y0.0+	A0+/CLR4+	-
14	NC	-	-	39	NC	-	-
15	NC	-	-	40	S/S	S/S	S/S
16	X0.15	DOG3	CntB3/CntB5	41	X0.14	DOG2	CntB3/CntA5
17	X0.13	DOG1	CntB2/CntB4	42	X0.12	DOG0	CntA2/CntA4
18	X0.11	DOG5	CntB1	43	X0.10	DOG4	CntA1
19	X0.9	MPGB	CntB0	44	X0.8	MPGA	CntA0
20	NC	-	-	45	NC	-	-
21	NC	-	-	46	NC	-	-
22	X0.3-	Pg3-	Rst3-/Rst5-	47	X0.3+	Pg3+	Rst3+/Rst5+
23	X0.2-	Pg2-	Rst2-/Rst4-	48	X0.2+	Pg2+	Rst2+/Rst4+
24	X0.1-	Pg1-	Rst1-	49	X0.1+	Pg1+	Rst1+
25	X0.0-	Pg0-	Rst0-	50	X0.0+	Pg0+	Rst0+

● External devices for AH15PM-5A

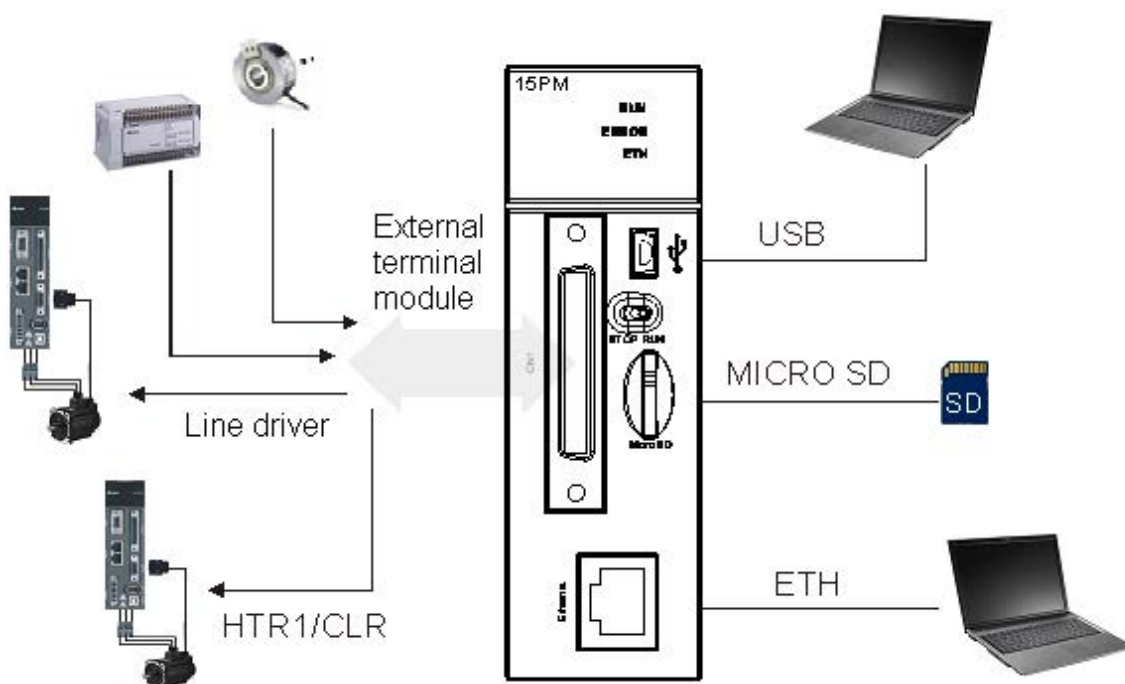

5

● Connector on AH15PM-5A

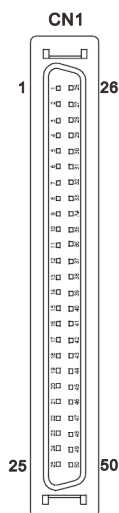

Pin	Terminal	Function		Pin	Terminal	Function	
		Pulse	Count			Pulse	Count
1	Y0.11	CLR3	-	26	Y0.10	CLR2	-
2	Y0.9	CLR1	-	27	Y0.8	CLR0	-
3	COM	COM	-	28	Y0.7+	B3+	-
4	Y0.7-	B3-	-	29	Y0.6+	A3+	-
5	Y0.6-	A3-	-	30	Y0.5+	B2+	-
6	Y0.5-	B2-	-	31	Y0.4+	A2+	-
7	Y0.4-	A2-	-	32	Y0.3+	B1+	-
8	Y0.3-	B1-	-	33	Y0.2+	A1+	-
9	Y0.2-	A1-	-	34	Y0.1+	B0+	-
10	Y0.1-	B0-	-	35	Y0.0+	A0+	-
11	Y0.0-	A0-	-	36	S/S	S/S	S/S
12	X1.5	CHG3	-	37	X1.4	CHG2	-
13	X1.3	CHG1	-	38	X1.2	CHG0	-
14	X1.1	LSN3	-	39	X1.0	LSP3	-
15	X0.15	LSN2	CntB3/CntB5	40	X0.14	LSP2	CntB3/CntA5
16	X0.13	LSN1	CntB2/CntB4	41	X0.12	LSP1	CntA2/CntA4
17	X0.11	LSN0	CntB1	42	X0.10	LSP0	CntA1
18	X0.9-	MPGB-	CntB0-	43	X0.9+	MPGB+	CntB0+
19	X0.8-	MPGA-	CntA0-	44	X0.8+	MPGA+	CntA0+
20	X0.7	DOG3	-	45	X0.6	DOG2	-
21	X0.5	DOG1	-	46	X0.4	DOG0	-
22	X0.3-	Pg3-	Rst3-/Rst5-	47	X0.3+	Pg3+	Rst3+/Rst5+
23	X0.2-	Pg2-	Rst2-/Rst4-	48	X0.2+	Pg2+	Rst2+/Rst4+
24	X0.1-	Pg1-	Rst1-	49	X0.1+	Pg1+	Rst1+
25	X0.0-	Pg0-	Rst0-	50	X0.0+	Pg0+	Rst0+

5.10.4.1 Wiring Input Terminals

The input signal is the direct-current power input. Sinking and sourcing are the current driving capability of a circuit. They are defined below.

- **Sinking**

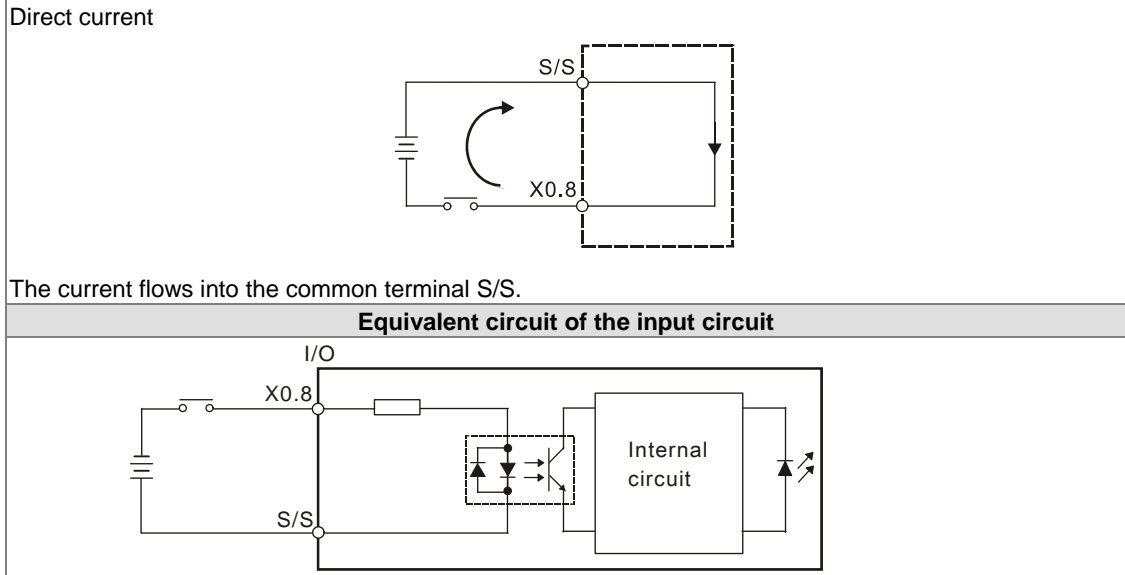

- **Sourcing**

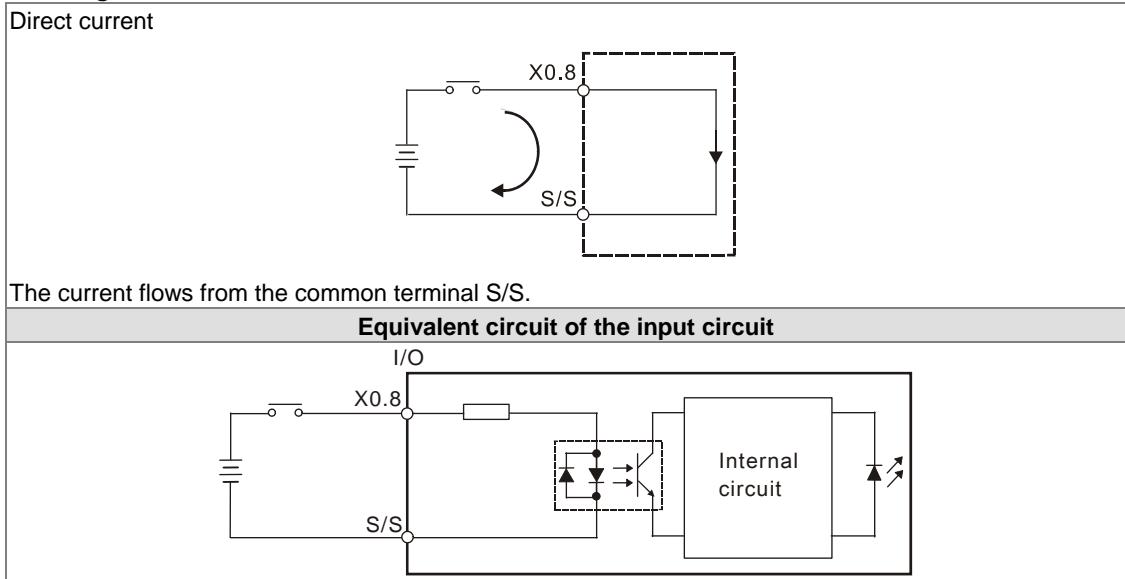

● **Wiring the differential input terminals**

The direct-current signals ranging in voltage from 5 V to 24 V can pass through the high-speed input terminals X0.0+~X0.3+ and X0.0~-X0.3- on AH10PM-5A, and X0.0+~X0.3+, X0.0~-X0.3-, X0.8+~X0.9+, and X0.8~-X0.9- on AH15PM-5A. (Only 24 V DC signals can pass through the other input terminals on AH10PM-5A and AH15PM-5A.) The frequency of input signals can be up to 200 kHz. If the frequency of input signals is less than 50 kHz and there is not much noise, these high-speed input terminals can be connected to the direct-current power supply whose voltage is in the range of 5 V to 24 V. The wiring diagrams for AH10PM-5A are shown below.

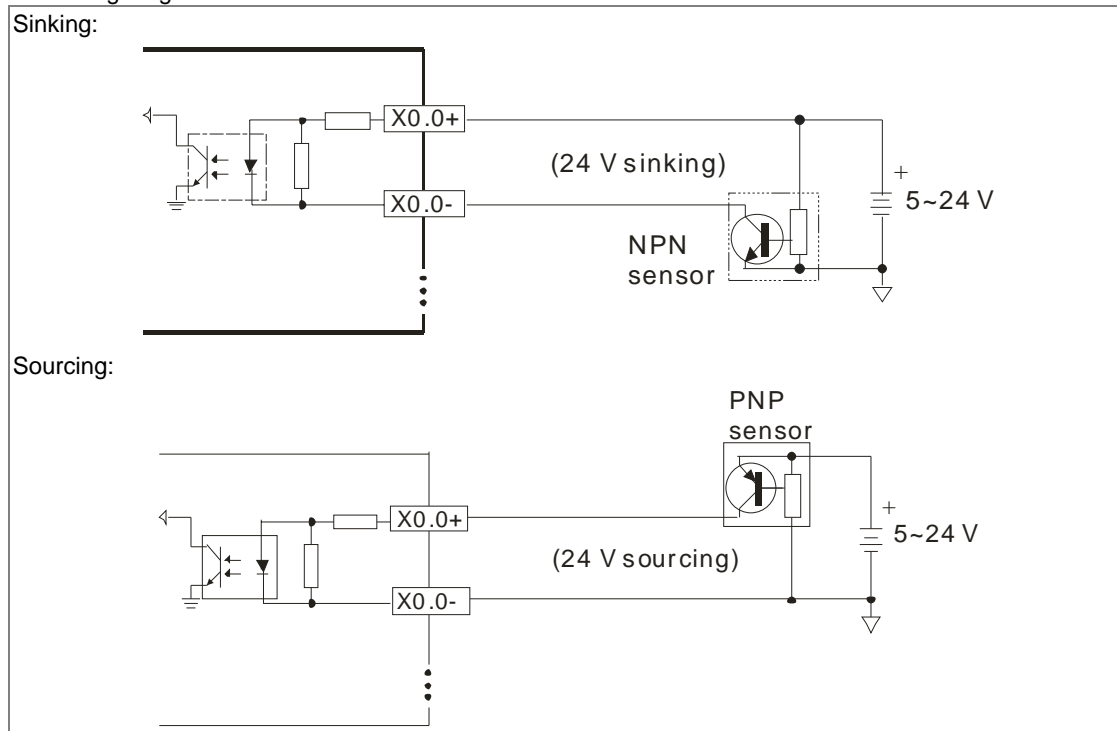

5

5.10.4.2 Wiring the Output Terminals

1. Transistor output circuit

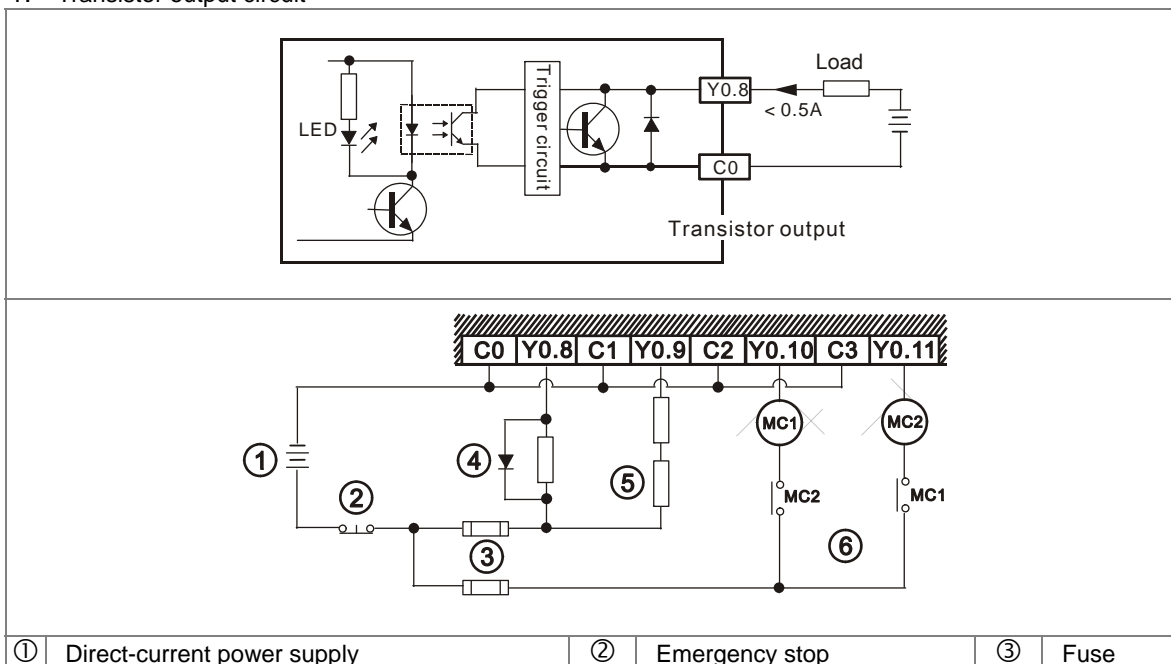

④	<p>The output terminals of a transistor module are open-collector output terminals. If Y0.8 is a pulse train output terminal of a transistor module, the output current passing through its output pull-up resistor must be greater than 0.1 A to ensure that the transistor module operates normally.</p> <p>A relay or a solenoid valve is used as a DC load. A diode is connected in parallel to absorb the surge voltage which occurs when the load is OFF.</p> <p>D: 1N4001 diode</p>
⑤	<p>A bulb (incandescent lamp) is used as a DC load. A thermistor is connected in series to absorb the surge current which occurs when the load is ON.</p> <p>NTC: 10Ω</p>
⑤	<p>Y0.9 can not be connected to a power supply directly. It must be connected to a load.</p>
⑥	<p>Mutually exclusive output: For example, Y0.10 controls the clockwise rotation of the motor, and Y0.11 controls the counterclockwise rotation of the motor. The interlock circuit which is formed, and the program in the PLC ensure that there are protective measures if an abnormal condition occurs.</p>

5

2. Wiring diagrams for the differential output terminals

- Wiring differential output terminals on AH05PM-5A/AH10PM-5A/AH15PM-5A, and an ASDA-A/ASDA-A+/ASDA-A2 series AC servo drive

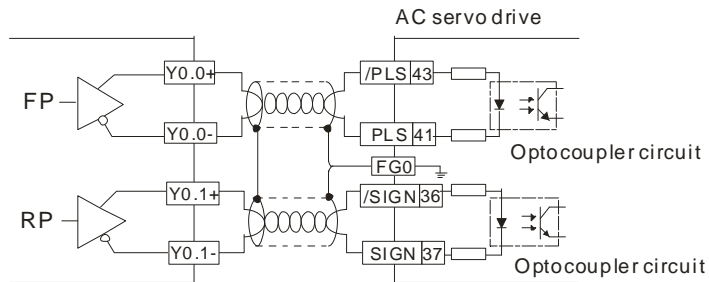

- Wiring differential output terminals on AH05PM-5A/AH10PM-5A/AH15PM-5A, and an ASDA-B series AC servo drive

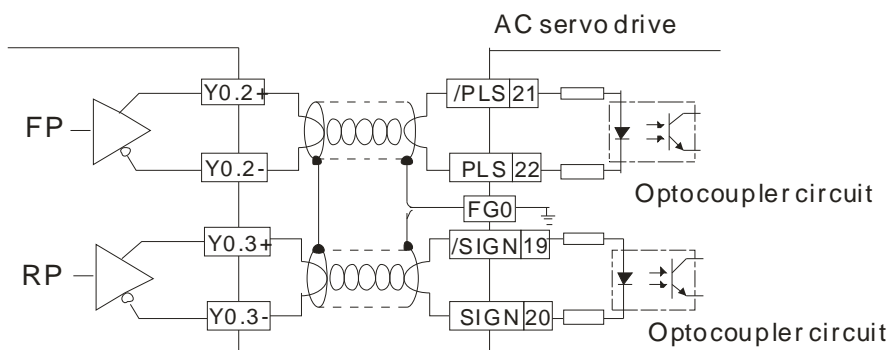

- Wiring differential output terminals on AH05PM-5A/AH10PM-5A/AH15PM-5A, and an ASDA-AB series AC servo drive

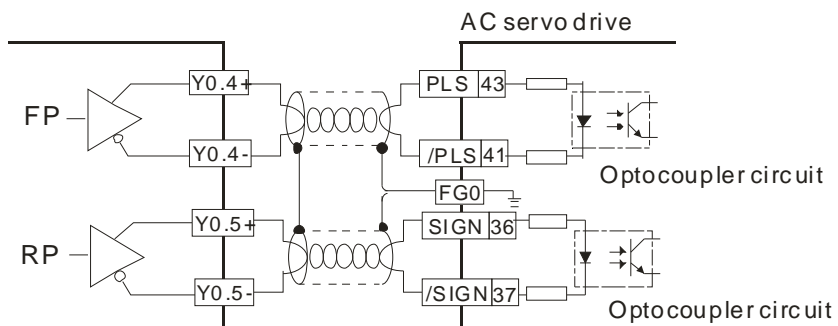

5

5.10.4.3 Wiring AH10PM-5A and an Inferior Servo Drive

- Wiring AH10PM-5A and a Delta ASDA-A series AC servo drive

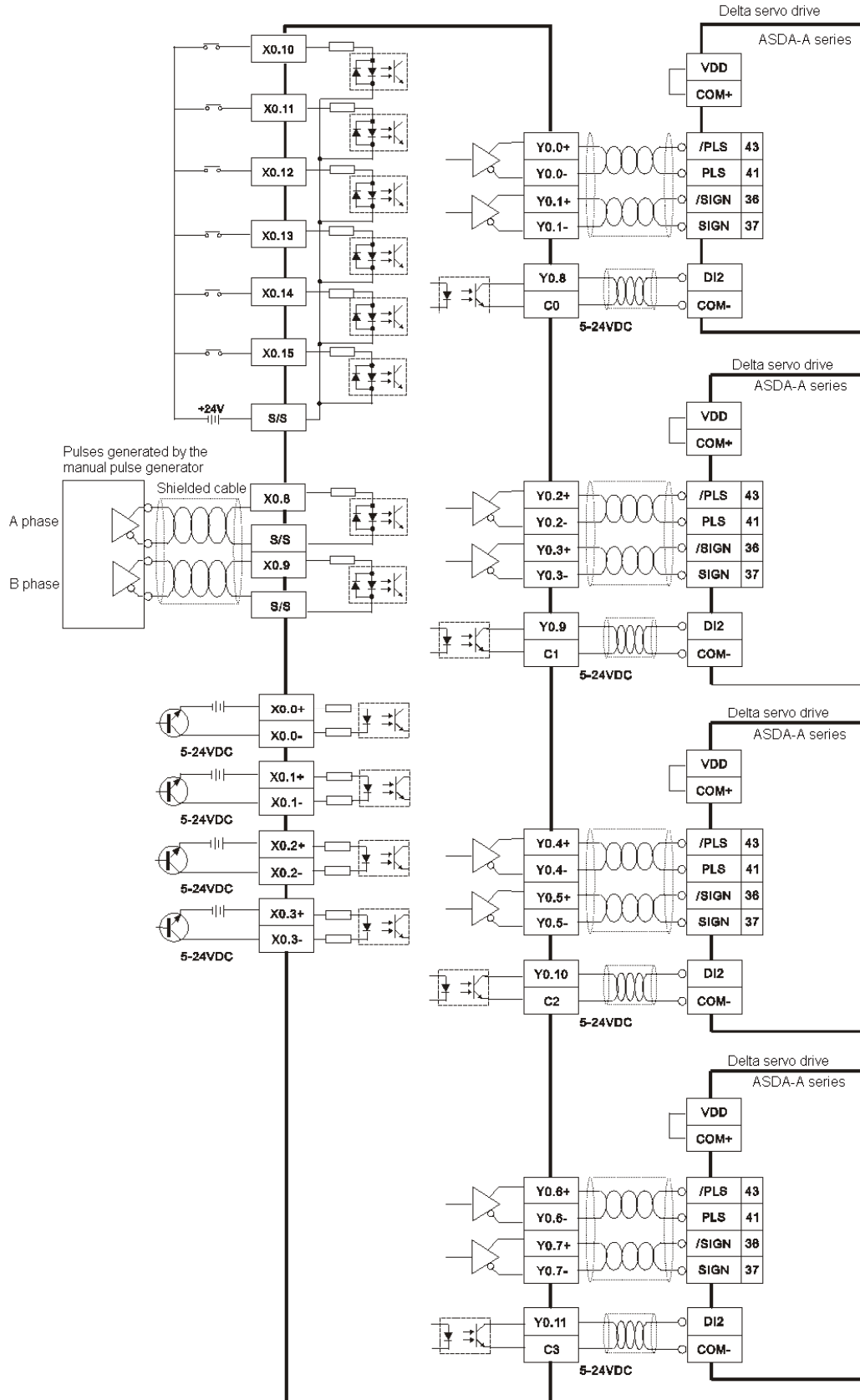

5

- Wiring AH10PM-5A and a Panasonic CN5 series servo drive

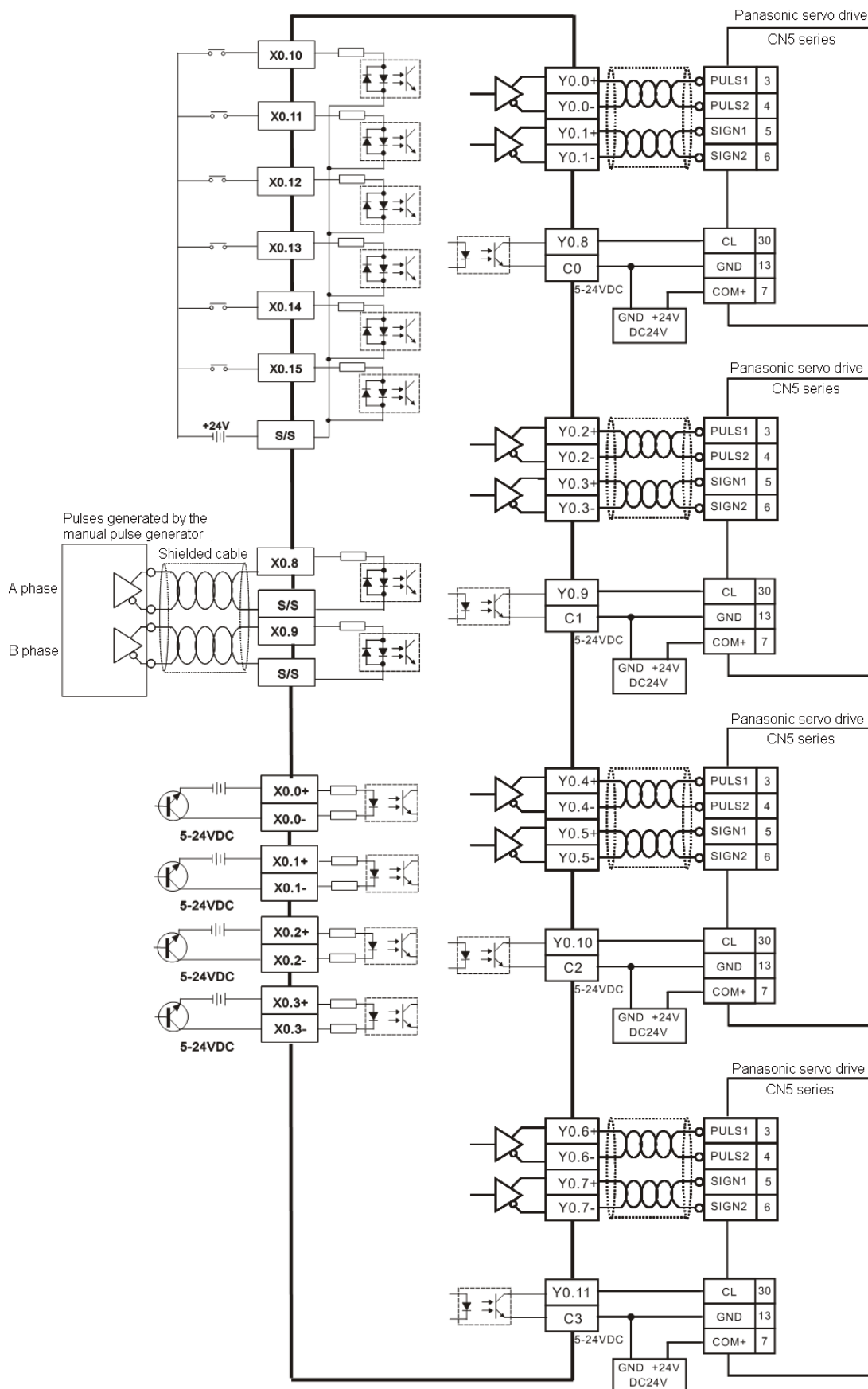

5

- Wiring AH10PM-5A and an Yaskawa servo drive

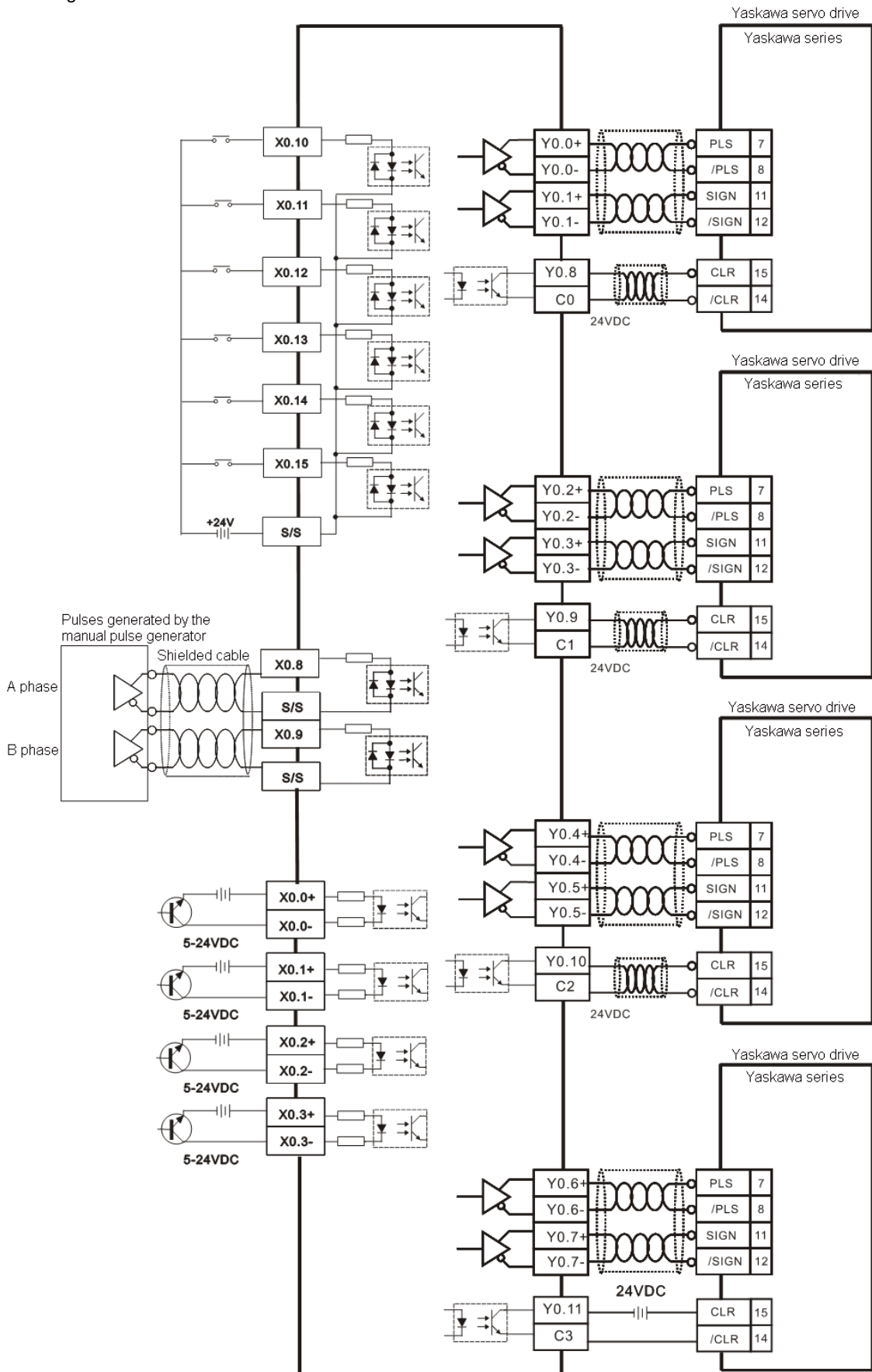

5

- Wiring AH10PM-5A and a Mitsubishi MJR2 series servo drive

5

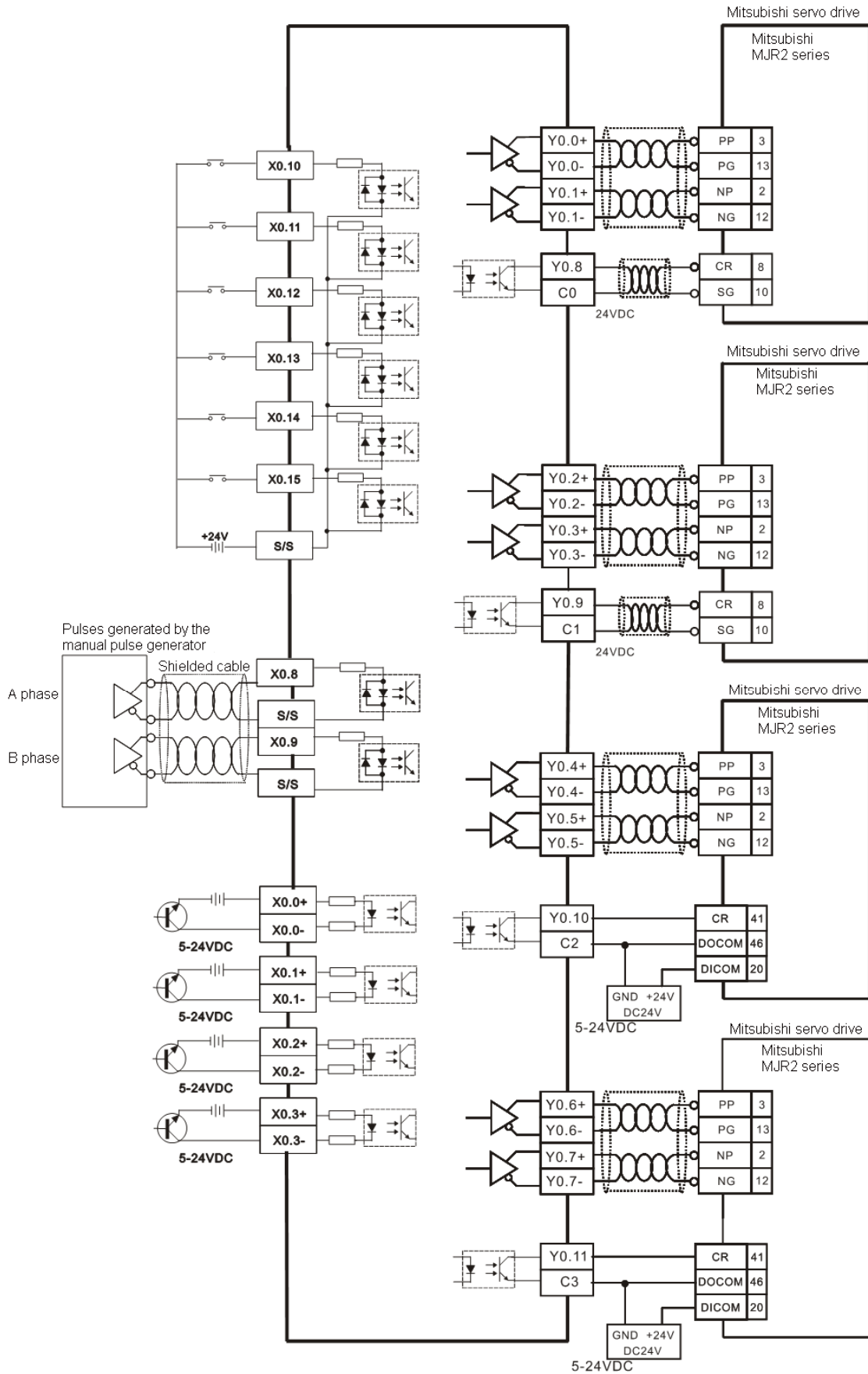

- Wiring AH10PM-5A and a Fuji servo drive

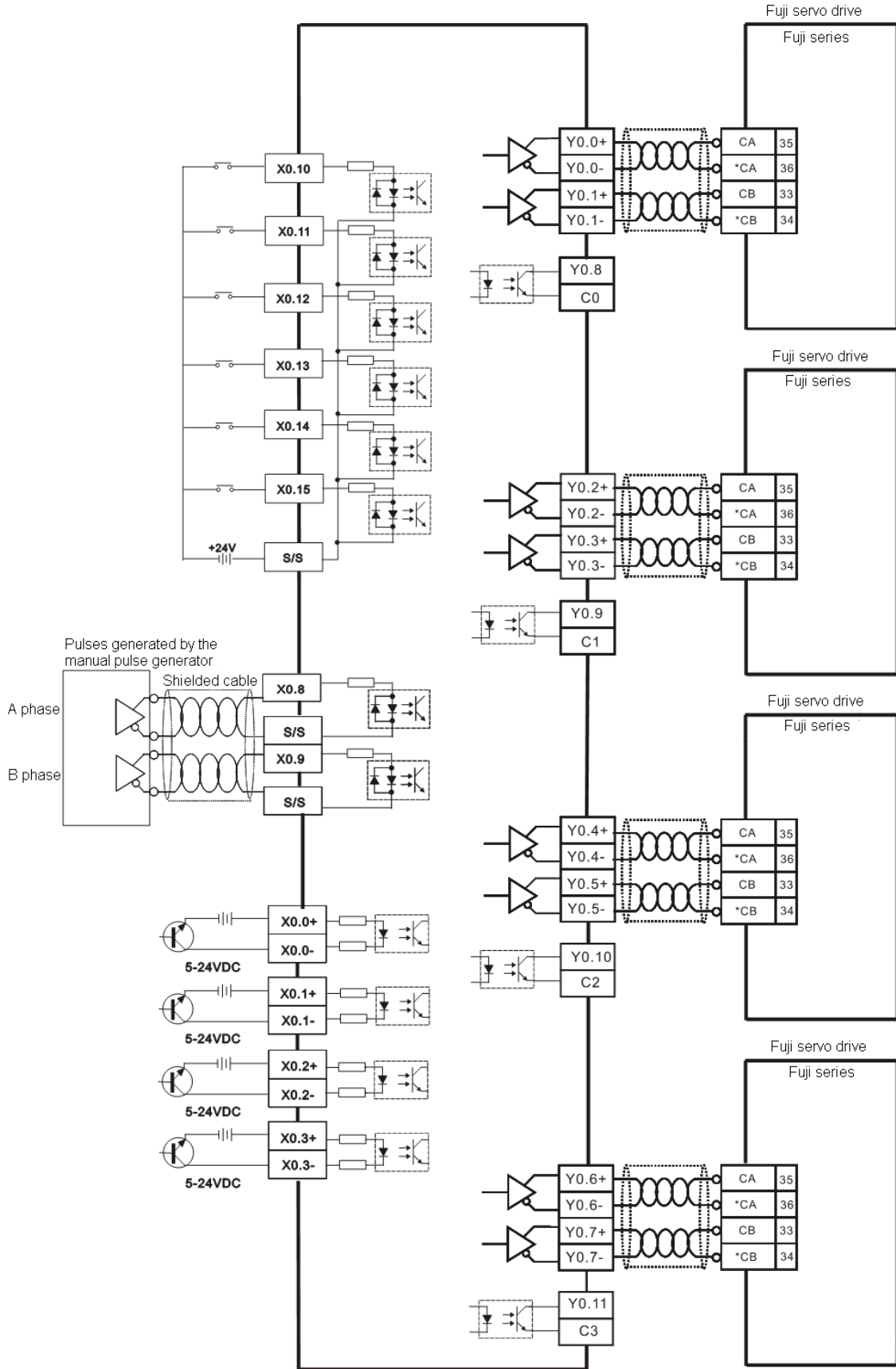

5

5.10.5 Wiring AH20MC-5A

- External devices for AH20MC-5A

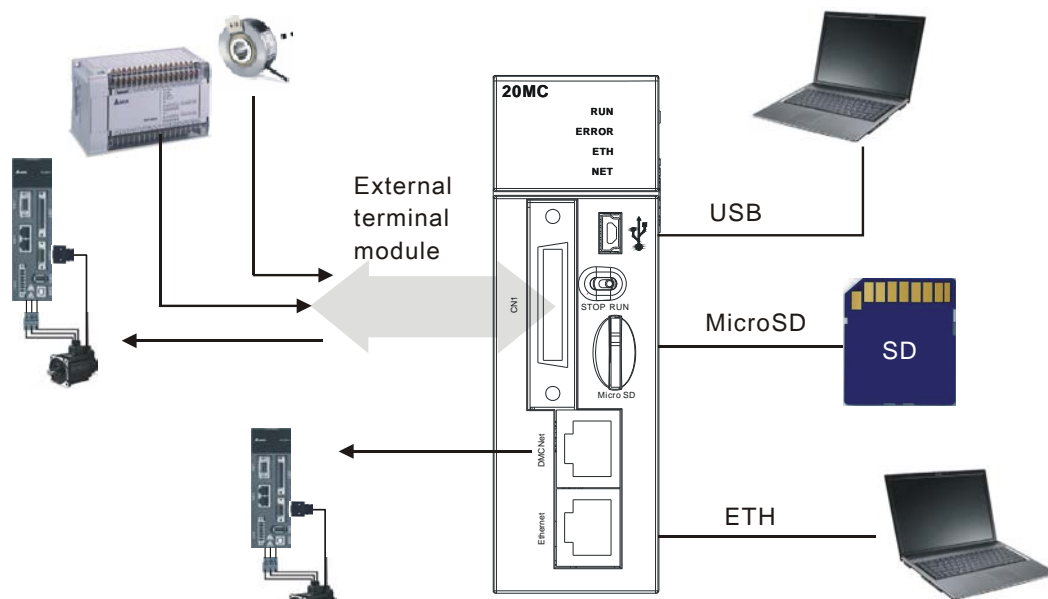

5

- Connector on AH20MC-5A

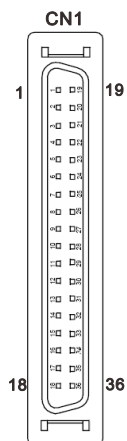

Pin	Terminal	Function		Pin	Terminal	Function	
		Pulse	Count			Pulse	Count
1	C3	-	COM3	19	Y0.11	-	Out3
2	C2	-	COM2	20	Y0.10	-	Out2
3	C1	-	COM1	21	Y0.9	-	Out1
4	C0	-	COM0	22	Y0.8	-	Out0
5	NC	-	-	23	NC	-	-
6	NC	-	-	24	NC	-	-
7	X0.3-	-	Rst3-/Rst5-	25	X0.3+	-	Rst3+/Rst5+
8	X0.15-	DOG3-	CntB3-/CntB5+	26	X0.15+	DOG3+	CntB3+/CntB5+
9	X0.14-	DOG2-	CntA3-/CntA5+	27	X0.14+	DOG2+	CntA3+/CntA5+
10	X0.2-	-	Rst2-/Rst4-	28	X0.2+	-	Rst2+/Rst4+
11	X0.13-	DOG1-	CntB2-/CntB4-	29	X0.13+	DOG1+	CntB2+/CntB4+
12	X0.12-	DOG0-	CntA2-/CntA4-	30	X0.12+	DOG0+	CntA2+/CntA4+
13	X0.1-	-	Rst1-	31	X0.1+	-	Rst1+
14	X0.11-	DOG5-	CntB1-	32	X0.11+	DOG5+	CntB1+
15	X0.10-	DOG4-	CntA1-	33	X0.10+	DOG4+	CntA1+
16	X0.0-	-	Rst0-	34	X0.0+	-	Rst0+
17	X0.9-	MPGB-	CntB0-	35	X0.9+	MPGB+	CntB0+
18	X0.8-	MPGA-	CntA0-	36	X0.8+	MPGA+	CntA0+

5.10.5.1 Wiring the Differential Input Terminals

The direct-current signals ranging in voltage from 5 V to 24 V can pass through the high-speed input terminals X0.0+~X0.3+, X0.0~-X0.3-, X0.8+~X0.15+, and X0.8~-X0.15- on AH20MC-5A. The frequency of input signals can be up to 200 kHz. These high-speed input terminals are connected to a differential (two-wire) line driver.

- Wiring differential input terminals (The wiring below is used for high speed and high noise.)

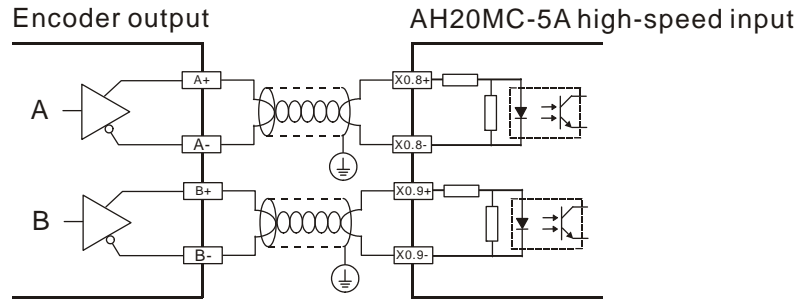

5.10.5.2 Transistor Output Circuit

AH20MC-5A

Transistor output

①	Direct-current power supply	②	Emergency stop	③	Fuse
---	-----------------------------	---	----------------	---	------

The output terminals of a transistor module are open-collector output terminals. If Y0.8 is a pulse train output terminal of a transistor module, the output current passing through its output pull-up resistor must be greater than 0.1 A to ensure that the transistor module operates normally. A relay or a solenoid valve is used as a DC load. A diode is connected in parallel to absorb the surge voltage which occurs when the load is OFF.

AH20MC-5A transistor output

D: 1N4001 diode

A bulb (incandescent lamp) is used as a DC load. A thermistor is connected in series to absorb the surge current which occurs when the load is ON.

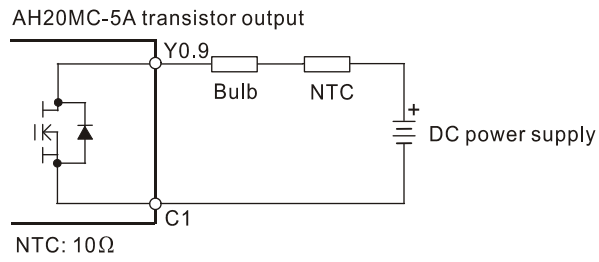

⑤

Y0.9 can not be connected to a power supply directly. It must be connected to a load.

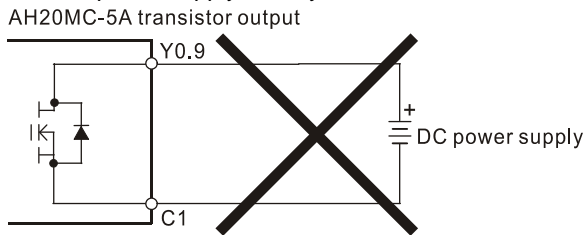

⑥

Mutually exclusive output: For example, Y0.10 controls the clockwise rotation of the motor, and Y0.11 controls the counterclockwise rotation of the motor. The interlock circuit which is formed, and the program in the PLC ensure that there are protective measures if an abnormal condition occurs.

6

Chapter 6 Memory Card

Table of Contents

6.1	Overview of Memory Cards.....	6-2
6.1.1	Appearances of Memory Cards.....	6-2
6.1.2	Specifications for Memory Cards.....	6-2
6.2	Installing and Removing a Memory Card	6-3
6.2.1	Formatting of a Memory Card and a Write Protect Tab	6-3
6.2.2	SD Slot in a CPU Module	6-3
6.2.3	Installing a Memory Card.....	6-4
6.2.4	Removing a Memory Card.....	6-4

6.1 Overview of Memory Cards

The AH500 series CPU modules support standard SD cards. Users can purchase products which meet specifications. The specifications for the SD cards supported by the AH500 series CPU modules, and the usage of the SD cards are described in this chapter.

6.1.1 Appearances of Memory Cards

SD cards are classified into three types according to size. They are SD cards, miniSD cards, and microSD cards. The AH500 series CPU modules support standard-sized SD cards.

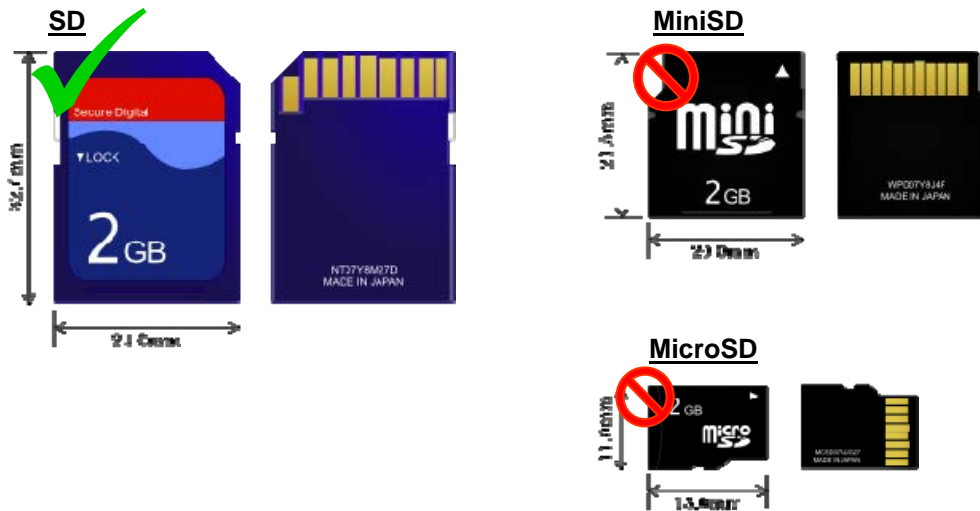

6.1.2 Specifications for Memory Cards

There are several specifications for SD cards on the market. SD cards not only can be classified according to size, but also can be classified into three types according to capacity. These types are SD cards, SDHC cards, and SDXC cards. The AH500 series CPU modules presently only support basic SD specifications. The following is the table of SD card families. The SD column indicates the specifications supported by the AH500 series CPU modules. Be sure to purchase products which meet the specifications.

- SD card families

Type	SD	SDHC			SDXC	
Capacity	2 GB Max.	4 GB~32 GB			32 GB~2 TB	
File system	FAT/FAT32	FAT32			exFAT	
Size	SD	SDHC	MiniSDHC	MicroSDHC	SDXC	MicroSDXC
Speed class rating	N/A	Class 2 (Min. 2 MB/sec.) Class 4 (Min. 4 MB/sec.) Class 6 (Min. 6 MB/sec.) Class 10 (Min. 10 MB/sec.)			Class 2 (Min. 2 MB/sec.) Class 4 (Min. 4 MB/sec.) Class 6 (Min. 6 MB/sec.) Class 10 (Min. 10 MB/sec.)	

* MMC cards are similar to SD cards in appearance. Users have to make sure that they purchase products which meet the specifications.

6.2 Installing and Removing a Memory Card

6.2.1 Formatting of a Memory Card and a Write Protect Tab

A memory card that users use for the first time may not be formatted. A memory card which is not formatted can not be used in an AH500 series CPU module. Therefore, users need to format the memory card. The file system with which the memory card is formatted is FAT.

In addition, there is usually a write protect tab on the left side of a memory card. If the tab is slid downward, data can not be written into the memory card. As a result, users have to make sure that the tab is slid upward before they use the memory card.

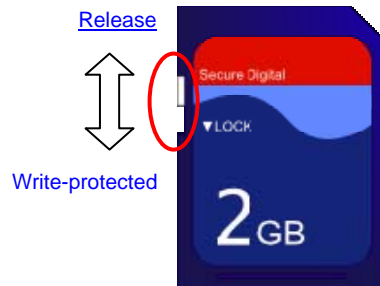

6.2.2 SD Slot in a CPU Module

As shown below, the SD slot is in the lower right corner of the front of a CPU module.

- AHCPU500/510/520/530-RS2

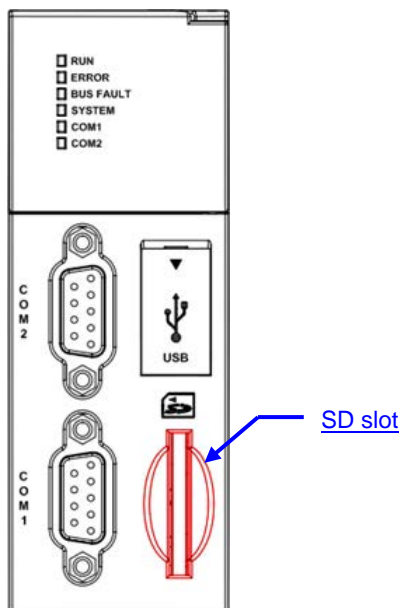

- AHCPU500/510/520/530-EN

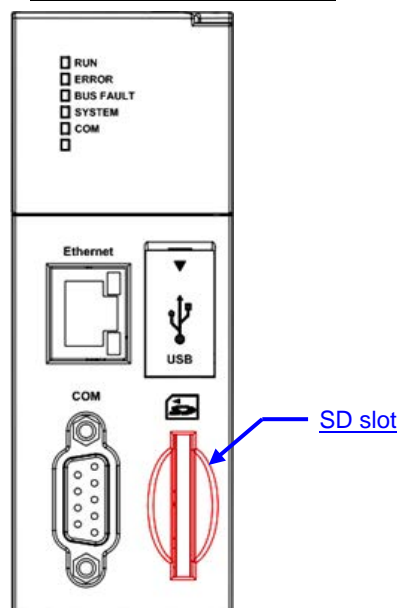

6.2.3 Installing a Memory Card

Insert a memory card into the SD slot in a CPU module, and push it downward until it clicks. After the memory card is installed, it is fixed firmly in the slot. If the memory card is loose, it is not installed correctly. Besides, the memory card has anti-misinsertion design. If it is inserted in the wrong direction, it can not be pushed downward. To prevent the CPU module from being damaged, users can not force the memory card in. The correct way to insert the memory card is shown below.

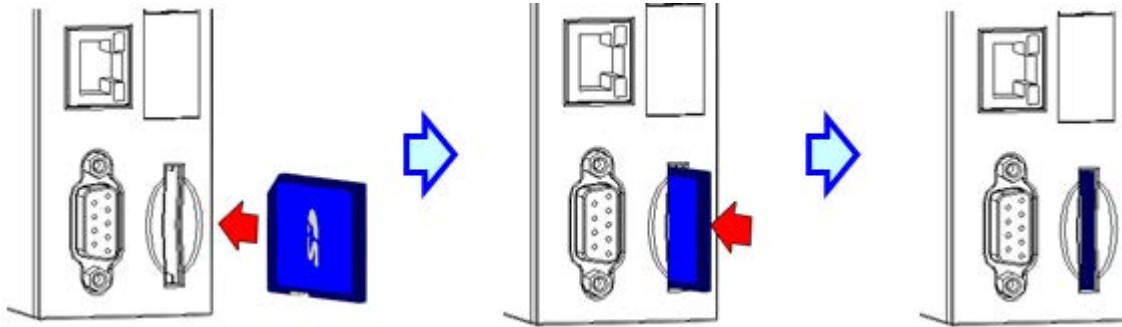

6.2.4 Removing a Memory Card

After a memory card is pushed downward, it springs from the slot, and users can take it out.

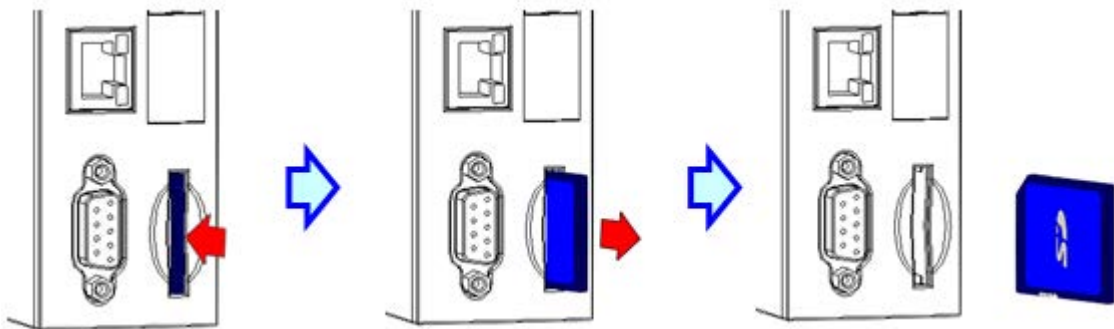



Chapter 7 EMC Standards

Table of Contents

7.1	EMC Standards for an AH500 System	7-2
7.1.1	EMC Standards Applicable to an AH500 System.....	7-2
7.1.2	Installation Instructions for the EMC Standards	7-3
7.1.3	Cables	7-3

7.1 EMC Standards for an AH500 System

7.1.1 EMC Standards Applicable to an AH500 System

The EMC standards which are applicable to an AH500 system are listed below.

- **EMI**

Port	Frequency range	Level (Normative)	Reference standard
Enclosure port (radiated) (measured at a distance of 10 meters)	30-230 MHz	40 dB (µV/m) quasi-peak	IEC 61000-6-4
	230-1000 MHz	47 dB (µV/m) quasi-peak	
AC power port (conducted)	0.15-0.5 MHz	79 dB (µV) quasi-peak	IEC 61000-6-4
		66 dB (µV) average	
	0.5-30 MHz	73 dB (µV) quasi-peak	
		60 dB (µV) average	

- **EMS**

Environmental phenomenon	Reference standard	Test	Test level	
Electrostatic discharge	IEC 61000-4-2	Contact	± 4 kV	
		Air	± 8 kV	
Radio frequency electromagnetic field Amplitude modulated	IEC 61000-4-3	80% AM, 1 kHz sinusoidal	2.0-2.7 GHz	1 V/m
			1.4-2.0 GHz	3 V/m
			80-1000 MHz	10 V/m
Power frequency magnetic field	IEC 61000-4-8	60 Hz	30 A/m	
		50 Hz	30 A/m	

- **Conducted immunity test**

Environmental phenomenon		Fast transient burst	High energy surge	Radio frequency interference
Reference standard		IEC 61000-4-4	IEC 61000-4-5	IEC 61000-4-6
Interface/Port	Specific interface/port	Test level	Test level	Test level
Data communication	Shielded cable	1 kV	1 kV CM	10V
	Unshielded cable	1 kV	1 kV CM	10V
Digital and analog I/O	AC I/O (unshielded)	2 kV	2 kV CM 1 kV DM	10V
	Analog or DC I/O(unshielded)	1 kV	1 kV CM	10V
	All shielded lines (to the earth)	1 kV	1 kV CM	10V
Equipment power	AC power	2 kV	2 kV CM 1 kV DM	10V
	DC power	2 kV	0.5 kV CM 0.5 kV DM	10V
I/O power and auxiliary power output	AC I/O and AC auxiliary power	2 kV	2 kV CM 1 kV DM	10V
	DC I/O and DC auxiliary power	2 kV	0.5 kV CM 0.5 kV DM	10V



7.1.2 Installation Instructions for the EMC Standards

A PLC must be installed in a control box. The control box protects the PLC, and shields off the electromagnetic interference generated by the PLC.

(1) Control box

- Use a conductive control box.
- To ensure that an inner plate contacts the control box well, users have to mask the paint on the bolts of the plate.
- To ensure that the control box is grounded well even if there is high-frequency noise, users have to connect the control box with a thick wire.
- The diameter of a hole in the control box must be less than 10 millimeters, i.e. 3.94 inches. If the diameter of the hole is larger than 10 millimeters, the radio frequency noise may be emitted.
- To prevent the radio waves from leaking through the interval between the door of the control box and the PLC, the interval needs to be reduced. Besides, users can prevent the radio waves from leaking by putting an EMI gasket on the painted surface.

(2) Connecting a power cable and a ground

The power cable of the PLC system and the ground are connected in a way described below.

- Provide a ground point near the power supply module. Use thick and short wires to connect the terminals LG and FG with the ground. (The length of the wire should be less than 30 centimeters, i.e. 11.18 inches.) LG and FG function to pass the noise generated by the PLC system to the ground. Therefore, the impedance should be as low as possible. Besides, the wires are used to relieve the noise. They themselves carry a lot of noise. Using the short wires can prevent the wires from acting as antennas.
- Twist the ground and the power cable. After the ground and the power cable are twisted, the noise flowing through the power cable is passed to the ground. If a filter is installed on the power cable, the ground and the power cable do not need to be twisted.

7.1.3 Cables

Grounding a shielded cable

Cables drawn from the control box carry high-frequency noise. When they are outside the control box, they are like antennas emitting noise. To prevent the emission of noise, the cables connected to digital input/output modules, analog input/output modules, temperature measurement modules, network modules, and motion control modules should be shielded cables.

The use of shielded cables also increases the resistance to noise. If the signal cables connected to digital input/output modules, analog input/output modules, temperature measurement modules, network modules, and motion control modules are shielded cables, and are grounded properly, the resistance to noise is improved. However, the resistance to noise will not meet the specified requirement if users do not use shielded cables or the shielded cables are not grounded correctly. If the shield of a cable is connected with the control box, users have to make sure that the shield contacts the control box. If the control box is painted, users have to scrape the paint. All fastening must be metal, and the shield must contact the surface of the control box. If the surface is not even, users need to use washers to correct the unevenness, or use an abrasive to level the surface.

If the shield of a shielded cable is grounded, it needs to be as close to a module as possible. Users have to make sure that there is no electromagnetic induction between the cable which is grounded and other cable which is grounded. Besides, users have to take appropriate measures so that the shield of a cable contacts the control box.



MEMO





Chapter 8 Maintenance and Inspection

Table of Contents

8.1	Cautions	8-2
8.2	Daily Maintenance.....	8-2
8.2.1	Tools Required for Inspection.....	8-2
8.2.2	Daily Inspection	8-3
8.3	Periodic Maintenance.....	8-3
8.3.1	Tools Required for Inspection.....	8-4
8.3.2	Periodic Inspection	8-4

8.1 Cautions

Before users undertake the maintenance and the inspection, they have to pay attention to the following items. **The incorrect or careless operation will lead to damage to the staff and the equipment.**



- To prevent a breakdown of an AH500 system or a fire accident, please make sure that the ambient environment is not exposed to corrosive substances such as chloride gas and sulfide gas, flammable substances such as oil mist and cutting powder, or dirt.



- To prevent the connectors from oxidizing, or to prevent the staff from getting an electric shock, please do not touch the connectors.



- To prevent the staff from getting an electric shock, please turn off the power before pulling the connectors or loosening the screws.



- To prevent the cables from being damaged, or to prevent the connectors from being loosened, please do not impose weight on the cable, or pull them violently.



- Please make sure that the input voltage is within the rated range.



- Please do not disassemble or alter the modules. Otherwise, the products will break down, a fire accident will occur, or the staff will be injured.
- To prevent a controlled element from malfunctioning, please make sure that the program and the parameters are written into a new CPU module which replaces an old one before restarting the AH500 system.
- To prevent the improper operation which results in the incorrect output or the damage to the equipment, please refer to the related manuals for more information about operating the modules.
- To prevent the damage to the modules, please touch metal which is grounded or wear an antistatic wrist strap to release the static electricity from the body.
- To prevent the noise from resulting in the breakdown of the system, please keep a proper distance from the system when using a cell phone or a communication apparatus.
- Please avoid installing an AH500 system under the sun or in a humid environment.
- To prevent the temperature of an element from being high, please make sure that the AH500 system keeps a proper distance from heat sources such as coils, heating apparatuses, and resistors.
- To protect an AH500 system, please install an emergency stop switch and an overcurrent protection according to the actual needs.
- Inserting and pulling a module several times may lead to the loose contact between the module and the backplane.
- To prevent an unexpected shock from resulting in the damage to an AH500 system and a controlled element, please make sure that the modules are installed firmly.

8.2 Daily Maintenance



To keep an AH500 system operating normally, please make sure that the ambient environment and the AH500 system conform to the cautions listed in section 8.1. Users then can undertake the daily inspection described below. If any abnormal situation occurs, please follow the remedy and carry out the maintenance.

8.2.1 Tools Required for Inspection

- A screwdriver
- Industrial alcohol
- A clean cotton cloth

8.2.2 Daily Inspection

No.	Item		Inspection	Criterion	Remedy
1	Appearance		Check visually.	Dirt must not be present.	Remove the dirt.
2	Installation of a backplane		Check whether the set screws are loose.	The backplane must be installed firmly.	Further tighten the screws.
			Check whether the backplane is installed on the DIN rail properly.		Install the backplane on the DIN rail properly.
3	Installation of a module		Check whether the module is loose, the projection is inserted into the hole on the backplane, and the screw is tightened.	The projection under the module must be inserted into the hole in the backplane, and the screw must be tightened.	Install the module firmly.
4	Connection		Check whether the removable terminal block is loose.	The removable terminal block must not be loose.	Install the terminal block firmly.
			Check whether the connector is loose.	The connector must not be loose.	Further tighten the screws on the connector.
5	Power supply module	POWER LED indicator	Check whether the POWER LED indicator is ON.	The POWER LED indicator must be ON.	Please refer to chapter 9 for more information about the troubleshooting.
	CPU module	RUN LED indicator	When the CPU module is running, check whether the RUN LED is ON.	The RUN LED indicator must be ON.	
		ERROR LED indicator	Check whether the ERROR LED indicator is OFF.	The ERROR LED indicator must be OFF.	
		BUS FAULT LED indicator	Check whether the BUS FAULT LED indicator is OFF.	The BUS FAULT LED indicator must be OFF.	
		SYSTEM LED indicator	Check whether the SYSTEM LED indicator is OFF.	The SYSTEM LED indicator must be OFF.	
	LED indicators on an extension module		Check whether the LED indicators on the extension module are ON.	If the LED indicators are ON, the module operates normally.	

* Please refer to Module Manual for more information related to the LED indicators on the extension modules.

8.3 Periodic Maintenance

Under the condition that the daily inspection is undertaken, users are suggested that they should carry out the periodic maintenance according to the actual operating environment. After making sure that the ambient environment and the AH500 system conform to the cautions listed in section 8.1, users then can undertake the periodic inspection described below. If any abnormal situation occurs, please follow the remedy and carry out the maintenance.



8.3.1 Tools Required for Inspection

- A screwdriver
- Industrial alcohol
- A clean cotton cloth
- A multimeter
- A thermometer
- A hygrometer

8.3.2 Periodic Inspection

No.	Item		Inspection	Criterion	Remedy
1	Ambient environment	Ambient temperature/humidity	The ambient temperature and the ambient humidity are measured by a thermometer and a hygrometer.	The ambient temperature and the ambient humidity must conform to the specifications for the modules or the backplane. If the specifications are different, the strictest specifications have high priority.	To ensure that the system operates in a stable environment, check the reason why the environment varies, and eliminate it.
		Atmosphere	Measure corrosive gas.	Corrosive gas must not be present.	
2	Supply voltage		Measure the AC power supply.	The power supply should meet the specifications for the power supply module.	Check the power supply.
3	Installation	Looseness	Check whether the module is loose.	The module must be installed firmly.	Please refer to chapter 2 for more information about installing the module.
		Adhesion of dirt	Check the appearance.	Dirt must not be present.	Remove the dirt.
4	Connection	Looseness of terminal screws	Tighten the screws with a screwdriver.	The screws must not be loose.	Further tighten the screws.
		Looseness of connectors	Pull the connectors.	The connectors must not be loose.	Further tighten the screws on the connectors.
5	PLC system diagnosis		Check the error logs.	No new error occurs.	Please refer to section 9.1.3 for more information.
6	Maximum scan time		Check the state of SR413 and that of SR414 through the device monitoring table in ISPSOft.	The maximum scan cycle must be within the range specified in the system specifications.	Check the reason why the scan time lengthens.



9

Chapter 9 Troubleshooting

Table of Contents

9.1	Troubleshooting for CPU Modules	9-2
9.1.1	ERROR LED Indicator's Being ON.....	9-2
9.1.2	ERROR LED Indicator's Blinking.....	9-3
9.1.3	BUS FAULT LED Indicator's Being ON.....	9-10
9.1.4	BUS FAULT LED Indicator's Blinking.....	9-11
9.1.5	Others.....	9-11
9.2	Troubleshooting for I/O Modules	9-21
9.2.1	Troubleshooting for Analog I/O Modules and Temperature Measurement Modules	9-21
9.2.2	Troubleshooting for AH02HC-5A/AH04HC-5A	9-24
9.2.3	Troubleshooting for AH05PM-5A/AH10PM-5A/AH15PM-5A.....	9-25
9.2.4	Troubleshooting for AH20MC-5A	9-27
9.2.5	Troubleshooting for AH10EN-5A.....	9-28
9.2.6	Troubleshooting for AH10SCM-5A	9-28
9.2.7	Troubleshooting for AH10DNET-5A	9-29
9.2.8	Troubleshooting for AH10PFBM-5A.....	9-30
9.2.9	Troubleshooting for AH10PFBS-5A.....	9-31
9.2.10	Troubleshooting for AH10COPM-5A	9-31

9.1 Troubleshooting for CPU Modules

Users can get the remedies from the tables below according to the statuses of the LED indicators and the error codes.

9.1.1 ERROR LED Indicator's Being ON

Error code	Description	Remedy
16#000B	The program in the PLC is damaged.	Download the program again.
16#000D	The CPU parameter is damaged.	Reset the CPU parameter, and download it.
16#0010	The access to the memory in the CPU is denied.	Download the program or parameters again. If the problem still occurs, please contact the factory.
16#0011	The PLC ID is incorrect. (SM9)	Please check the PLC ID.
16#0012	The PLC password is incorrect. (SM9)	Please check the PLC password.
16#0014	The procedure of restoring the system can not be executed. (SM9)	The contents of the system backup file are incorrect, or the file does not exist in the path specified. If the file exists and the procedure of restoring the system can not be executed, please backing up the system again. If the error still occurs, please contact the factory. (Please refer to section 7.5 in AH500 Operation Manual, and section 18.2 in ISPSOFT User Manual for more information about the memory card.)
16#0015	The module table is incorrect. (SM10)	The module table stored in the CPU module is incorrect. Compare the module table in HWCONFIG with the actual module configuration, and download the module table again.
16#0016	The module setting is incorrect. (SM10)	The module setting stored in the CPU module is incorrect. Check whether the version of the module inserted in the slot is the same as the version of the module in HWCONFIG. After the version of the module is updated, users can download the module setting again.
16#0017	The data register exceeds the device range. (SM10)	The data register stored in the CPU module exceeds the device range. Check whether the module parameter in HWCONFIG is correct, and download the module parameter again.
16#001B	Timed interrupt 0 is set incorrectly.	Set the CPU parameter in HWCONFIG again, and download the CPU parameter again.
16#001C	Timed interrupt 1 is set incorrectly.	Set the CPU parameter in HWCONFIG again, and download the CPU parameter again.
16#001D	Timed interrupt 2 is set incorrectly.	Set the CPU parameter in HWCONFIG again, and download the CPU parameter again.
16#001E	Timed interrupt 3 is set incorrectly.	Set the CPU parameter in HWCONFIG again, and download the CPU parameter again.
16#001F	The watchdog timer is set incorrectly.	Set the CPU parameter in HWCONFIG again, and download the CPU parameter again.
16#0020	The setting of the fixed scan time is incorrect.	Set the CPU parameter in HWCONFIG again, and download the CPU parameter again.
16#0021	The setting of the fixed scan time is incorrect.	Set the CPU parameter in HWCONFIG again, and download the CPU parameter again.
16#0022	The CPU parameter downloaded to the PLC is incorrect.	Download the CPU parameter again.

Error code	Description	Remedy
16#0050	The memories in the latched special auxiliary relays are abnormal.	After users reset the CPU module or restore it to the factory setting, they can download the program and the parameter again.
16#0051	The latched special data registers are abnormal.	After users reset the CPU module or restore it to the factory setting, they can download the program and the parameter again.
16#0052	The memories in the latched auxiliary relays are abnormal.	After users reset the CPU module or restore it to the factory setting, they can download the program and the parameter again.
16#0053	The latched timers are abnormal.	After users reset the CPU module or restore it to the factory setting, they can download the program and the parameter again.
16#0054	The latched counters are abnormal.	After users reset the CPU module or restore it to the factory setting, they can download the program and the parameter again.
16#0055	The latched 32-bit counters are abnormal.	After users reset the CPU module or restore it to the factory setting, they can download the program and the parameter again.
16#0056	The memories in the latched timers are abnormal.	After users reset the CPU module or restore it to the factory setting, they can download the program and the parameter again.
16#0057	The memories in the latched counters are abnormal.	After users reset the CPU module or restore it to the factory setting, they can download the program and the parameter again.
16#0058	The memories in the latched 32-bit counters are abnormal.	After users reset the CPU module or restore it to the factory setting, they can download the program and the parameter again.
16#0059	The latched data registers are abnormal.	After users reset the CPU module or restore it to the factory setting, they can download the program and the parameter again.
16#005A	The latched working registers are abnormal.	After users reset the CPU module or restore it to the factory setting, they can download the program and the parameter again.

9.1.2 ERROR LED Indicator's Blinking

Error code	Description	Remedy
16#000A	Scan timeout (SM8: The watchdog timer error)	1. Check the setting of the watchdog timer in HWCONFIG. 2. Check whether the program causes the long scan time
16#000C	The program downloaded to the PLC is incorrect.	After users compile the program again, they can download the program again.
16#000E	The program or the parameter is being downloaded, and therefore the PLC can not run.	After the program or the parameter is downloaded to the PLC, users can try to run the PLC.
16#0018	The serial port is abnormal. (SM9)	Retry the connection. If the error still occurs, please contact the factory.
16#0019	The USB is abnormal. (SM9)	Retry the connection. If the error still occurs, please contact the factory.
16#0033	The communication setting of COM1 is incorrect. (SM9)	1. Check the program and the related special data registers. 2. Set the communication port parameter for the CPU module in HWCONFIG again.

Error code	Description	Remedy
16#0034	The setting of the station address of COM1 is incorrect. (SM9)	<ol style="list-style-type: none"> 1. Check the program and the related special data registers. 2. Set the communication port parameter for the CPU module in HWCONFIG again.
16#0035	The setting of the communication type of COM1 is incorrect. (SM9)	<ol style="list-style-type: none"> 1. Check the program and the related special data registers. 2. Set the communication port parameter for the CPU module in HWCONFIG again.
16#0036	The interval of retrying the sending of the command through COM1 is set incorrectly.(SM9)	<ol style="list-style-type: none"> 1. Check the program and the related special data registers. 2. Set the communication port parameter for the CPU module in HWCONFIG again.
16#0037	The number of times the sending of the command through COM1 is retried is set incorrectly. (SM9)	<ol style="list-style-type: none"> 1. Check the program and the related special data registers. 2. Set the communication port parameter for the CPU module in HWCONFIG again.
16#0038	The communication setting of COM2 is incorrect. (SM9)	<ol style="list-style-type: none"> 1. Check the program and the related special data registers. 2. Set the communication port parameter for the CPU module in HWCONFIG again.
16#0039	The setting of the station address of COM2 is incorrect. (SM9)	<ol style="list-style-type: none"> 1. Check the program and the related special data registers. 2. Set the communication port parameter for the CPU module in HWCONFIG again.
16#003A	The setting of the communication type of COM2 is incorrect. (SM9)	<ol style="list-style-type: none"> 1. Check the program and the related special data registers. 2. Set the communication port parameter for the CPU module in HWCONFIG again.
16#003B	The interval of retrying the sending of the command through COM2 is set incorrectly.(SM9)	<ol style="list-style-type: none"> 1. Check the program and the related special data registers. 2. Set the communication port parameter for the CPU module in HWCONFIG again.
16#003C	The number of times the sending of the command through COM2 is retried is set incorrectly. (SM9)	<ol style="list-style-type: none"> 1. Check the program and the related special data registers. 2. Set the communication port parameter for the CPU module in HWCONFIG again.
16#005D	The CPU module does not detect a memory card. (SM453)	Check whether a memory card is inserted into the CPU module correctly.
16#005E	The memory card is initialized incorrectly. (SM453)	Check whether the memory card breaks down.
16#005F	The data is read from the inexistent file in the memory card, or the data is written into the inexistent file in the memory card. (SM453)	Check whether the file path is correct.
16#0060	The default folder can not be created in the CPU module. (SM453)	Check whether the capacity of the memory card is large enough, or whether the memory card breaks down.
16#0061	The capacity of the memory card is not large enough. (SM453)	Check whether the capacity of the memory card is large enough.
16#0062	The memory card is write protected. (SM453)	Check whether the memory card is write protected.

Error code	Description	Remedy
16#0063	An error occurs when the data is written into the memory card. (SM453)	Check whether the file path is correct, or whether the memory card breaks down.
16#0064	The file in the memory card can not be read. (SM453)	Check whether the file path is correct, or whether the file is damaged.
16#0065	The file in the memory card is a read-only file. (SM453)	Users need to set the file so that the file is not a read-only file.
16#0066	An error occurs when the system is backed up.	<ol style="list-style-type: none"> 1. Check whether the memory card is normal, and whether the capacity of the memory card is large enough. 2. Retry the backup procedure. If the error still occurs, please contact the factory.
16#2000	There is no END in the program in the PLC. (SM5)	<ol style="list-style-type: none"> 1. Compile the program again, and download the program again. 2. Reinstall ISPSOft, compile the program again, and download the program again.
16#2002	GOEND is used incorrectly. (SM5)	Check the program, compile the program again, and download the program again.
16#2003	The devices used in the program exceed the range. (SM0/SM5)	Check the program, compile the program again, and download the program again.
16#2004	The part of the program specified by the label used in CJ/JMP is incorrect, or the label is used repeatedly. (SM0/SM5)	Check the program, compile the program again, and download the program again.
16#2005	The N value used in MC is not the same as the corresponding N value used in MCR, or the number of N values used in MC is not the same as the number of N values used in MCR. (SM5)	Check the program, compile the program again, and download the program again.
16#2006	The N values used in MC do not start from 0, or the N values used in MC are not continuous. (SM5)	Check the program, compile the program again, and download the program again.
16#2007	The operands used in ZRST are not used properly. (SM5)	Check the program, compile the program again, and download the program again.
16#200A	Invalid instruction (SM5)	Check the program, compile the program again, and download the program again.
16#200B	The operand n or the other constant operands exceed the range. (SM0/SM5)	Check the program, compile the program again, and download the program again.
16#200C	The operands overlap. (SM0/SM5)	Check the program, compile the program again, and download the program again.
16#200D	An error occurs when the binary number is converted into the binary-coded decimal number. (SM0/SM5)	Check the program, compile the program again, and download the program again.
16#200E	The string does not end with 0x00. (SM0/SM5)	Check the program, compile the program again, and download the program again.
16#200F	The instruction does not support the modification by an index register. (SM5)	Check the program, compile the program again, and download the program again.

Error code	Description	Remedy
16#2010	1. The instruction does not support the device. 2. Encoding error 3. The instruction is a 16-bit instruction, but the constant operand is a 32-bit code. (SM5)	Check the program, compile the program again, and download the program again.
16#2011	The number of operands is incorrect. (SM5)	Check the program, compile the program again, and download the program again.
16#2012	Incorrect division operation (SM0/SM5).	Check the program, compile the program again, and download the program again.
16#2013	The value exceeds the range of values which can be represented by the floating-point numbers. (SM0/SM5)	Check the program, compile the program again, and download the program again.
16#2014	The task designated by TKON/YKOFF is incorrect, or exceeds the range. (SM5)	Check the program, compile the program again, and download the program again.
16#2015	There are more than 32 levels of nested program structures supported by CALL. (SM0)	Check the program, compile the program again, and download the program again.
16#2016	There are more than 32 levels of nested program structures supported by FOR/NEXT. (SM0/SM5)	Check the program, compile the program again, and download the program again.
16#2017	The number of times FOR is used is different from the number of times NEXT is used. (SM5)	Check the program, compile the program again, and download the program again.
16#2018	There is a label after FEND, but there is no SRET. There is SRET, but there is no label. (SM5)	1. Compile the program again, and download the program again. 2. Reinstall ISPSOft, compile the program again, and download the program again.
16#2019	The interrupt task is not after FEND. (SM5)	1. Compile the program again, and download the program again. 2. Reinstall ISPSOft, compile the program again, and download the program again.
16#201A	IRET/SRET is not after FEND. (SM5)	1. Compile the program again, and download the program again. 2. Reinstall ISPSOft, compile the program again, and download the program again.
16#201B	There is an interrupt task, but there is no IRET. There is IRET, but there is not interrupt task. (SM5)	1. Compile the program again, and download the program again. 2. Reinstall ISPSOft, compile the program again, and download the program again.
16#201C	End is not at the end of the program. (SM5)	1. Compile the program again, and download the program again. 2. Reinstall ISPSOft, compile the program again, and download the program again.
16#201D	There is CALL, but there is no MAR. (SM5)	1. Compile the program again, and download the program again. 2. Reinstall ISPSOft, compile the program again, and download the program again.

Error code	Description	Remedy
16#201E	The function code used in MODRW is incorrect. (SM102/SM103)	Check the usage of the instruction and the setting of the operands. Please refer to the explanation of the instruction MODRW in AH500 Programming Manual for more information.
16#201F	The length of the data set in MODRW is incorrect. (SM102/SM103)	Check the usage of the instruction and the setting of the operands. Please refer to the explanation of the instruction MODRW in AH500 Programming Manual for more information.
16#2020	The communication command received by using MODRW is incorrect. (SM102/SM103)	Check whether the slave supports the function code and the specified operation.
16#2021	The checksum of the command received is incorrect. (SM102/SM103)	1. Check whether there is noise, and retry the sending of the command. 2. Check whether the slave operates normally.
16#2022	The format of the command used in MODRW does not conform to the ASCII format. (SM102/SM103)	Make sure that the format of the command conforms to the ASCII format.
16#2023	There is a communication timeout when MODRW is executed. (SM120/SM103)	Check whether the slave operates normally, and whether the connection is normal.
16#2024	The setting value of the communication timeout is invalid. (SM120/SM103)	1. Check the program and the related special data registers. 2. Set the communication port parameter for the CPU module in HWCONFIG again.
16#2025	There is a communication timeout when RS is executed. (SM120/SM103)	Check whether the slave operates normally, and whether the connection is normal.
16#6000	Ethernet connection error (SM1106)	1. Check the program and the related special data registers. 2. Set the Ethernet parameter for the CPU module in HWCONFIG again.
16#6001	Illegal IP address (SM1107)	1. Check the program and the related special data registers. 2. Set the Ethernet parameter for the CPU module in HWCONFIG again.
16#6002	Illegal netmask address (SM1107)	1. Check the program and the related special data registers. 2. Set the Ethernet parameter for the CPU module in HWCONFIG again.
16#6003	Illegal gateway mask (SM1107)	1. Check the program and the related special data registers. 2. Set the Ethernet parameter for the CPU module in HWCONFIG again.
16#6004	The IP address filter is set incorrectly. (SM1108)	Set the Ethernet parameter for the CPU module in HWCONFIG again.
16#6006	The static ARP table is set incorrectly. (SM1108)	Set the Ethernet parameter for the CPU module in HWCONFIG again.
16#6008	Illegal network number (SM1107)	Check the network configuration in NWCONFIG, and download it again.
16#6009	Illegal node number (SM1107)	Check the network configuration in NWCONFIG, and download it again.
16#6101	The trigger in the email is set incorrectly. (SM1112)	Set the Ethernet parameter for the CPU module in HWCONFIG again.

Error code	Description	Remedy
16#6102	The interval of sending the email is set incorrectly. (SM1112)	Set the Ethernet parameter for the CPU module in HWCONFIG again.
16#6103	The device containing the data specified as the attachment exceeds the device range. (SM1112)	Set the Ethernet parameter for the CPU module in HWCONFIG again.
16#6106	The SMTP server address is incorrect. (SM1112)	Make sure that the address is correct, and set the Ethernet parameter for the CPU module in HWCONFIG again.
16#6108	SMTP authentication error (SM1112)	Check the user name, and the password. Set the Ethernet parameter for the CPU module in HWCONFIG again.
16#6110	The SMTP server needs to be authenticated. (SM1112)	Check the user name, and the password. Set the Ethernet parameter for the CPU module in HWCONFIG again.
16#6111	The specified email address does not exist. (SM1112)	1. Check whether the email address is correct. 2. Set the Ethernet parameter for the CPU module in HWCONFIG again.
16#6200	The remote IP address set in the TCP socket function is illegal. (SM1196)	1. Check the program and the related special data registers. 2. Set the Ethernet parameter for the CPU module in HWCONFIG again.
16#6209	The remote IP address set in the UDP socket function is illegal. (SM1196)	1. Check the program and the related special data registers. 2. Set the Ethernet parameter for the CPU module in HWCONFIG again.
16#6300	Only auxiliary relays, data registers, and link registers can be used in the Ether Link.	Check the setting of the Ether Link in NWCONFIG, and download it again.
16#6301	The device used in the Ether Link exceeds the device range.	Check whether the device used in the Ether Link is within the device range supported by the CPU module.
16#6302	The length of the data exchanged in the Ether Link exceeds the limit.	Check whether the length of the data exchanged in the Ether Link is within the range supported by the CPU module.
16#6305	The node used in the communication command is different from the local node.	Check the setting of the Ether Link in NWCONFIG, and download it again.
16#630A	The module ID or the setting of the module is different from the setting in the Ether Link.	1. Check the setting of the parameter in HWCONFIG. 2. Check the setting of the Ether Link in NWCONFIG.
16#630B	The setting of the netmask address for the CPU or the module is different from the setting in the Ether Link.	1. Check the setting of the parameter in HWCONFIG. 2. Check the setting of the Ether Link in NWCONFIG.
16#6602	The node number exceeds the limit. (SM1598)	Check the network configuration in NWCONFIG, and download it again.
16#6603	The device is undefined. (SM1599)	Check the network configuration in NWCONFIG, and download it again.
16#8230	The CPU parameter downloaded is incorrect. The IP address is illegal.	1. Check the Ethernet parameter in the CPU module in HWCONFIG. 2. Check whether the version of HWCONFIG used now is compatible with the version of the CPU.

Error code	Description	Remedy
16#8231	The CPU parameter downloaded is incorrect. The netmask address is illegal.	<ol style="list-style-type: none"> 1. Check the Ethernet parameter in the CPU module in HWCONFIG. 2. Check whether the version of HWCONFIG used now is compatible with the version of the CPU.
16#8232	The CPU parameter downloaded is incorrect. The gateway address is illegal.	<ol style="list-style-type: none"> 1. Check the Ethernet parameter in the CPU module in HWCONFIG. 2. Check whether the version of HWCONFIG used now is compatible with the version of the CPU.
16#8233	The CPU parameter downloaded is incorrect. The IP address filter is set incorrectly.	<ol style="list-style-type: none"> 1. Check the Ethernet parameter in the CPU module in HWCONFIG. 2. Check whether the version of HWCONFIG used now is compatible with the version of the CPU.
16#8235	The CPU parameter downloaded is incorrect. The static ARP table is set incorrectly.	<ol style="list-style-type: none"> 1. Check the Ethernet parameter in the CPU module in HWCONFIG. 2. Check whether the version of HWCONFIG used now is compatible with the version of the CPU.
16#8237	The CPU parameter downloaded is incorrect. The network number is illegal.	<ol style="list-style-type: none"> 1. Check the network configuration in NWCONFIG. 2. Check whether the version of HWCONFIG used now is compatible with the version of the CPU.
16#8238	The CPU parameter downloaded is incorrect. The node number is illegal.	<ol style="list-style-type: none"> 1. Check the network configuration in NWCONFIG. 2. Check whether the version of HWCONFIG used now is compatible with the version of the CPU.
16#8239	The CPU parameter downloaded is incorrect. The email is set incorrectly.	<ol style="list-style-type: none"> 1. Check the Ethernet parameter in the CPU module in HWCONFIG. 2. Check whether the version of HWCONFIG used now is compatible with the version of the CPU.
16#823A	The CPU parameter downloaded is incorrect. The trigger in the email is set incorrectly.	<ol style="list-style-type: none"> 1. Check the Ethernet parameter in the CPU module in HWCONFIG. 2. Check whether the version of HWCONFIG used now is compatible with the version of the CPU.
16#823B	The CPU parameter downloaded is incorrect. The TCP socket is set incorrectly.	<ol style="list-style-type: none"> 1. Check the Ethernet parameter in the CPU module in HWCONFIG. 2. Check whether the version of HWCONFIG used now is compatible with the version of the CPU.
16#823C	The CPU parameter downloaded is incorrect. The UDP socket is set incorrectly.	<ol style="list-style-type: none"> 1. Check the Ethernet parameter in the CPU module in HWCONFIG. 2. Check whether the version of HWCONFIG used now is compatible with the version of the CPU.

9.1.3 BUS FAULT LED Indicator's Being ON

When a CPU module detects an error, the BUS FAULT LED indicator on the CPU module is ON. The BUS FAULT LED indicator on the CPU module corresponds to the ERROR LED indicator on an I/O module. If an error occurs in an I/O module, the status of the BUS FAULT LED indicator on the CPU module is the same as that of the ERROR LED indicator on the I/O module. If there are errors occurring in the I/O modules, the BUS FAULT LED indicator on the CPU module will be ON. For example, the BUS FAULT LED indicator on the CPU module will be ON if the ERROR LED indicator on I/O module A is ON and the ERROR LED indicator on I/O module B blinks. If the ERROR LED indicator on I/O module B still blinks after the error occurring in I/O module A is eliminated, the BUS FAULT LED indicator on the CPU module will blink. Please refer to sections 12.4.2~12.4.8 in AH500 Operation Manual for more information about the LED indicators.

Users can get the remedies for the errors detected by a CPU module from the table below. If the error code which users get is not listed in the table below, users need to check whether the I/O module operates normally. Please refer to section 9.2 in this manual for more information about the troubleshooting for I/O modules.

Error code	Description	Remedy
16#0013	The I/O module can not run/stop. (SM10)	Check whether the setting of the parameter for the module is correct. If the setting is correct, please check whether the module breaks down. If the error still occurs, please contact the factory.
16#0014	The procedure of restoring the system can not be executed. (SM9)	The contents of the system backup file are incorrect, or the file does not exist in the path specified. If the file exists and the procedure of restoring the system can not be executed, please backing up the system again. If the error still occurs, please contact the factory. (Please refer to section 7.5 in AH500 Operation Manual, and section 18.2 in ISPSOFT User Manual for more information about the memory card.)
16#1400	An error occurs when the data is accessed through the auxiliary processor. (SM9)	Please contact the factory.
16#1401	An error occurs when the data in the I/O module is accessed. (SM9)	Please contact the factory.
16#1402	The actual arrangement of the I/O modules is not consistent with the module table. (SM9)	Check whether the module table in HWCONFIG is consistent with the actual arrangement of the I/O modules.
16#1403	An error occurs when the data is read from the module. (SM9)	Check whether the module operates normally. If the error still occurs, please contact the factory.
16#1404	A watchdog timer error occurs in the module. (SM9)	Check whether the module breaks down. If the module breaks down, please replace it and contact the factory.
16#1405	The setting parameter of the module is not found. (SM9)	Set the parameter in HWCONFIG again, and download it.
16#1406	A communication error occurs when the data is accessed through the main processor. (SM9)	Check whether there is noise, and eliminate the noise. If the error still occurs, please contact the factory.
16#1407	A communication error occurs when the data is accessed through the auxiliary processor. (SM9)	Check whether there is noise, and eliminate the noise. If the error still occurs, please contact the factory.
16#1408	The communication with the module is incorrect. (SM9)	Check whether there is noise, and eliminate the noise. If the error still occurs, please contact the factory.

Error code	Description	Remedy
16#1409	The extension backplane is disconnected. (SM9)	<ol style="list-style-type: none"> 1. Check whether the extension backplane is connected properly. 2. Check whether the extension backplane operates normally, and make sure that the extension backplane is not affected by noise.
16#140A	The communication with the extension backplane is incorrect. (SM9)	<ol style="list-style-type: none"> 1. Check whether the extension backplane is connected properly. 2. Check whether the extension backplane operates normally, and make sure that the extension backplane is not affected by noise.
16#140B	The number of network modules exceeds the limit. (SM9)	Please decrease the number of network modules to the number supported by the system.

9.1.4 BUS FAULT LED Indicator's Blinking

If the BUS FAULT LED blinks, please check the operating state of the module. Please refer to sections 12.4.2~12.4.8 in AH500 Operation Manual for more information about the LED indicators, and section 9.2 in this manual for more information about the troubleshooting for I/O modules.

9.1.5 Others

Error code	Description	Remedy
16#000F	The original program in the PLC is damaged.	After users compile the program again, they can download the program again.
16#2026	The interrupt number used in RS is incorrect.	Compile the program again, and download the program again. If the error still occurs, please contact the factory.
16#600A	TCP connection failure (SM1090)	<ol style="list-style-type: none"> 1. Check the actual network configuration, and check whether the number of TCP connections exceeds the upper limit supported by the CPU module. 2. Retry the TCP connection later. (This error does not cause the PLC to stop running. Users can perform the corresponding remedy by means of the related flag in the program.)
16#600B	UDP connection failure (SM1091)	<ol style="list-style-type: none"> 1. Check the actual network configuration, and check whether the number of UDP connections exceeds the upper limit supported by the CPU module. 2. Retry the TCP connection later. (This error does not cause the PLC to stop running. Users can perform the corresponding remedy by means of the related flag in the program.)
16#600C	The TCP socket has been used. (SM1109)	<ol style="list-style-type: none"> 1. Check whether the actual data access results in the use of the same socket. 2. Change the socket number, or retry the socket later. (This error does not cause the PLC to stop running. Users can perform the corresponding remedy by means of the related flag in the program.)
16#600D	The RJ45 port is not connected.	Check the communication cable.
16#6100	The email connection is busy. (SM1113)	Retry the email connection later. (This error does not cause the PLC to stop running. Users can perform the corresponding remedy by means of the related flag in the program.)
16#6104	The attachment in the email does not exist. (SM1113)	Check whether the attachment exists in the memory card.

Error code	Description	Remedy
16#6105	The attachment in the email is oversized. (SM1113)	Check the size of the file which is specified as the attachment. If the size is over 2 MB, the file can not be specified as the attachment.
16#6107	There is an SMTP server response timeout. (SM1113)	<ol style="list-style-type: none"> 1. Check whether the status of the SMTP server is normal. 2. Retry the sending of the email later. (This error does not cause the PLC to stop running. Users can perform the corresponding remedy by means of the related flag in the program.)
16#6201	The local communication port set in the TCP socket function is illegal.	<ol style="list-style-type: none"> 1. Check the program and the related special data registers. 2. Set the Ethernet parameter for the CPU module in HWCONFIG again.
16#6202	The remote communication port set in the TCP socket function is illegal.	<ol style="list-style-type: none"> 1. Check the program and the related special data registers. 2. Set the Ethernet parameter for the CPU module in HWCONFIG again.
16#6203	The device from which the data is sent in the TCP socket function is illegal.	<ol style="list-style-type: none"> 1. Check the program and the related special data registers. 2. Set the Ethernet parameter for the CPU module in HWCONFIG again.
16#6204	The transmitted data length set in the TCP socket function is illegal.	<ol style="list-style-type: none"> 1. Check the program and the related special data registers. 2. Set the Ethernet parameter for the CPU module in HWCONFIG again.
16#6205	The data which is sent through the TCP socket exceeds the device range.	<ol style="list-style-type: none"> 1. Check the program and the related special data registers. 2. Set the Ethernet parameter for the CPU module in HWCONFIG again.
16#6206	The device which receives the data in the TCP socket function is illegal.	<ol style="list-style-type: none"> 1. Check the program and the related special data registers. 2. Set the Ethernet parameter for the CPU module in HWCONFIG again.
16#6207	The received data length set in the TCP socket function is illegal.	<ol style="list-style-type: none"> 1. Check the program and the related special data registers. 2. Set the Ethernet parameter for the CPU module in HWCONFIG again.
16#6208	The data which is received through the TCP socket exceeds the device range.	<ol style="list-style-type: none"> 1. Check the program and the related special data registers. 2. Set the Ethernet parameter for the CPU module in HWCONFIG again.
16#620A	The local communication port set in the UDP socket function is illegal.	<ol style="list-style-type: none"> 1. Check the program and the related special data registers. 2. Set the Ethernet parameter for the CPU module in HWCONFIG again.
16#620B	The remote communication port set in the UDP socket function is illegal.	<ol style="list-style-type: none"> 1. Check the program and the related special data registers. 2. Set the Ethernet parameter for the CPU module in HWCONFIG again.
16#620C	The device from which the data is sent in the UDP socket function is illegal.	<ol style="list-style-type: none"> 1. Check the program and the related special data registers. 2. Set the Ethernet parameter for the CPU module in HWCONFIG again.

Error code	Description	Remedy
16#620D	The transmitted data length set in the UDP socket function is illegal.	<ol style="list-style-type: none"> 1. Check the program and the related special data registers. 2. Set the Ethernet parameter for the CPU module in HWCONFIG again.
16#620E	The data which is sent through the UDP socket exceeds the device range.	<ol style="list-style-type: none"> 1. Check the program and the related special data registers. 2. Set the Ethernet parameter for the CPU module in HWCONFIG again.
16#620F	The device which receives the data in the UDP socket function is illegal.	<ol style="list-style-type: none"> 1. Check the program and the related special data registers. 2. Set the Ethernet parameter for the CPU module in HWCONFIG again.
16#6210	The received data length set in the UDP socket function is illegal.	<ol style="list-style-type: none"> 1. Check the program and the related special data registers. 2. Set the Ethernet parameter for the CPU module in HWCONFIG again.
16#6211	The data which is received through the UDP socket exceeds the device range.	<ol style="list-style-type: none"> 1. Check the program and the related special data registers. 2. Set the Ethernet parameter for the CPU module in HWCONFIG again.
16#6212	There is no response from the remote device after the timeout period.	Make sure that the remote device is connected.
16#6213	The data received exceeds the limit.	<ol style="list-style-type: none"> 1. Check the program and the related special data registers. 2. Set the Ethernet parameter for the CPU module in HWCONFIG again.
16#6214	The remote device refuses the connection.	Make sure that the remote device operates normally.
16#6215	The socket is not opened.	Check whether operational sequence in the program is correct.
16#6217	The socket is opened.	Check whether operational sequence in the program is correct.
16#6218	The data has been sent through the socket.	Check whether operational sequence in the program is correct.
16#6219	The data has been received through the socket.	Check whether operational sequence in the program is correct.
16#621A	The socket is closed.	Check whether operational sequence in the program is correct.
16#6303	The remote device in the Ether Link aborts the connection.	<ol style="list-style-type: none"> 1. Check the connection and the status of the remote device. 2. Check whether the remote device supports the Ether Link.
16#6304	The connection in the Ether Link is busy.	<ol style="list-style-type: none"> 1. Check whether the number of connections in the Ether Link exceeds the system load. 2. Retry the connection in the Ether Link later.
16#6309	The remote device in the Ether Link does not respond after the timeout period.	<ol style="list-style-type: none"> 1. Check whether the CPU module in the Ether Link operates normally. 2. Check whether the CPU modules are connected normally.
16#6400	The number of TCP connections reaches the upper limit, or the flag which is related to the sending of the data is not set to ON.	<ol style="list-style-type: none"> 1. Check whether the flag which is related to the sending of the data in the program is modified. 2. Retry the setting of the flag and the sending of the packet.

Error code	Description	Remedy
16#6401	The remote device aborts the connection.	Check whether the remote device support the Modbus port (502).
16#6402	There is no response from the remote device after the timeout period.	Check whether the remote device operate normally.
16#6403	The remote IP address used in the applied instruction is illegal.	Check whether the program is correct.
16#6404	The Modbus function code not supported is received.	Check the command transmitted from the remote device.
16#6405	The number of data which will be received is not consistent with the actual length of the data.	Check the command transmitted from the remote device.
16#6500	The initialization of the data exchange fails. (SM699)	Check whether the sum of the number of Modbus TCP data exchange blocks and the number of the Ether Link data exchange blocks exceeds the system specifications, and download the setting again.
16#6501	The remote device involved in the data exchange does not respond after the timeout period. (SM828~SM955)	Check the device whose connection number corresponds to the error flag, and check whether it is connected normally.
16#6502	The remote device involved in the data exchange does not respond correctly. (SM828~SM955)	Check the device whose connection number corresponds to the error flag, and check whether it is connected normally.
16#6600	The network number which receives the command exceeds the range.	Check the command transmitted from the remote device.
16#6601	The network is undefined in the network configuration parameter.	Check the network configuration in NWCONFIG, and download it again.
16#6604	The number of routing connections reaches the upper limit.	Resend the packet later. ((This error does not cause the PLC to stop running. Users can perform the corresponding remedy by means of the related flag in the program.)
16#6605	The unexpected packet is received.	Check the command transmitted from the remote device.
16#6606	There is a routing response timeout.	1. Check the network configuration in NWCONFIG. 2. Check whether the setting of the communication timeout conform to the practical application.
16#8105	The contents of the program downloaded are incorrect. The program syntax is incorrect.	1. Check whether the program syntax which is not supported by the CPU module is used, and check whether the version of the firmware has its special limitation. 2. Check whether the version of ISPSOft used to create the program is the same as the version of ISPSOft used now.
16#8106	The contents of the program downloaded are incorrect. The length of the execution code exceeds the limit.	1. Shorten the length of the program, and download the program again. 2. Check whether the version of ISPSOft used to create the program is the same as the version of ISPSOft used now.
16#8107	The contents of the program downloaded are incorrect. The length of the source code exceeds the limit.	1. Shorten the length of the program, and download the program again. 2. Check whether the version of ISPSOft used to create the program is the same as the version of ISPSOft used now.

Error code	Description	Remedy
16#820E	The communication port parameter downloaded is incorrect. The communication protocol is incorrect.	1. Check the setting of the communication port parameter for the CPU module in HWCONFIG. 2. Check whether the version of HWCONFIG used now is compatible with the version of the CPU.
16#820F	The communication port parameter downloaded is incorrect. The setting of the station address is incorrect.	1. Check the setting of the communication port parameter for the CPU module in HWCONFIG. 2. Check whether the version of HWCONFIG used now is compatible with the version of the CPU.
16#8210	The communication port parameter downloaded is incorrect. The choice among RS-232, RS-485, and SR-422 is incorrect.	1. Check the setting of the communication port parameter for the CPU module in HWCONFIG. 2. Check whether the version of HWCONFIG used now is compatible with the version of the CPU.
16#8211	The communication port parameter downloaded is incorrect. The interval of retrying the sending of the command is set incorrectly.	1. Check the setting of the communication port parameter for the CPU module in HWCONFIG. 2. Check whether the version of HWCONFIG used now is compatible with the version of the CPU.
16#8212	The communication port parameter downloaded is incorrect. The number of times the sending of the command is retried is set incorrectly.	1. Check the setting of the communication port parameter for the CPU module in HWCONFIG. 2. Check whether the version of HWCONFIG used now is compatible with the version of the CPU.
16#8215	The CPU parameter downloaded is incorrect. The interval of executing interrupt 0 is set incorrectly.	1. Check the setting of the basic parameter for the CPU module in HWCONFIG. 2. Check whether the version of HWCONFIG used now is compatible with the version of the CPU.
16#8216	The CPU parameter downloaded is incorrect. The interval of executing interrupt 1 is set incorrectly.	1. Check the setting of the basic parameter for the CPU module in HWCONFIG. 2. Check whether the version of HWCONFIG used now is compatible with the version of the CPU.
16#8217	The CPU parameter downloaded is incorrect. The interval of executing interrupt 2 is set incorrectly.	1. Check the setting of the basic parameter for the CPU module in HWCONFIG. 2. Check whether the version of HWCONFIG used now is compatible with the version of the CPU.
16#8218	The CPU parameter downloaded is incorrect. The interval of executing interrupt 3 is set incorrectly.	1. Check the setting of the basic parameter for the CPU module in HWCONFIG. 2. Check whether the version of HWCONFIG used now is compatible with the version of the CPU.
16#8219	The CPU parameter downloaded is incorrect. The watchdog timer is set incorrectly.	1. Check the setting of the basic parameter for the CPU module in HWCONFIG. 2. Check whether the version of HWCONFIG used now is compatible with the version of the CPU.
16#821A	The CPU parameter downloaded is incorrect. The setting of the scan time is incorrect.	1. Check the setting of the basic parameter for the CPU module in HWCONFIG. 2. Check whether the version of HWCONFIG used now is compatible with the version of the CPU.
16#821B	The CPU parameter downloaded is incorrect. The setting of the remote execution function is incorrect.	1. Check the setting of the basic parameter for the CPU module in HWCONFIG. 2. Check whether the version of HWCONFIG used now is compatible with the version of the CPU.
16#821D	The CPU parameter downloaded is incorrect. An error occurs in the latched area.	1. Check the setting of the basic parameter for the CPU module in HWCONFIG. 2. Check whether the version of HWCONFIG used now is compatible with the version of the CPU.

Error code	Description	Remedy
16#9A13	The setting of the data exchange for slave 19 in the PLC Link is incorrect. (SM1590)	1. Check the program and the related special data registers. 2. Set the PLC Link parameter in HWCONFIG again.
16#9A14	The setting of the data exchange for slave 20 in the PLC Link is incorrect. (SM1590)	1. Check the program and the related special data registers. 2. Set the PLC Link parameter in HWCONFIG again.
16#9A15	The setting of the data exchange for slave 21 in the PLC Link is incorrect. (SM1590)	1. Check the program and the related special data registers. 2. Set the PLC Link parameter in HWCONFIG again.
16#9A16	The setting of the data exchange for slave 22 in the PLC Link is incorrect. (SM1590)	1. Check the program and the related special data registers. 2. Set the PLC Link parameter in HWCONFIG again.
16#9A17	The setting of the data exchange for slave 23 in the PLC Link is incorrect. (SM1590)	1. Check the program and the related special data registers. 2. Set the PLC Link parameter in HWCONFIG again.
16#9A18	The setting of the data exchange for slave 24 in the PLC Link is incorrect. (SM1590)	1. Check the program and the related special data registers. 2. Set the PLC Link parameter in HWCONFIG again.
16#9A19	The setting of the data exchange for slave 25 in the PLC Link is incorrect. (SM1590)	1. Check the program and the related special data registers. 2. Set the PLC Link parameter in HWCONFIG again.
16#9A1A	The setting of the data exchange for slave 26 in the PLC Link is incorrect. (SM1590)	1. Check the program and the related special data registers. 2. Set the PLC Link parameter in HWCONFIG again.
16#9A1B	The setting of the data exchange for slave 27 in the PLC Link is incorrect. (SM1590)	1. Check the program and the related special data registers. 2. Set the PLC Link parameter in HWCONFIG again.
16#9A1C	The setting of the data exchange for slave 28 in the PLC Link is incorrect. (SM1590)	1. Check the program and the related special data registers. 2. Set the PLC Link parameter in HWCONFIG again.
16#9A1D	The setting of the data exchange for slave 29 in the PLC Link is incorrect. (SM1590)	1. Check the program and the related special data registers. 2. Set the PLC Link parameter in HWCONFIG again.
16#9A1E	The setting of the data exchange for slave 30 in the PLC Link is incorrect. (SM1590)	1. Check the program and the related special data registers. 2. Set the PLC Link parameter in HWCONFIG again.
16#9A1F	The setting of the data exchange for slave 31 in the PLC Link is incorrect. (SM1590)	1. Check the program and the related special data registers. 2. Set the PLC Link parameter in HWCONFIG again.
16#9A20	The setting of the data exchange for slave 32 in the PLC Link is incorrect. (SM1590)	1. Check the program and the related special data registers. 2. Set the PLC Link parameter in HWCONFIG again.
16#9A21	An error occurs when the master communicates with slave 1 in the PLC Link. (SM1591)	1. Check the communication setting in the master, and the communication setting in slave 1. 2. Check the communication cable.
16#9A22	An error occurs when the master communicates with slave 2 in the PLC Link. (SM1591)	1. Check the communication setting in the master, and the communication setting in slave 2. 2. Check the communication cable.
16#9A23	An error occurs when the master communicates with slave 3 in the PLC Link. (SM1591)	1. Check the communication setting in the master, and the communication setting in slave 3. 2. Check the communication cable.
16#9A24	An error occurs when the master communicates with slave 4 in the PLC Link. (SM1591)	1. Check the communication setting in the master, and the communication setting in slave 4. 2. Check the communication cable.

Error code	Description	Remedy
16#9A5B	There is no response from slave 27 in the PLC Link. (SM1592)	1. Check the communication setting in the master, and the communication setting in slave 27. 2. Check the communication cable.
16#9A5C	There is no response from slave 28 in the PLC Link. (SM1592)	1. Check the communication setting in the master, and the communication setting in slave 28. 2. Check the communication cable.
16#9A5D	There is no response from slave 29 in the PLC Link. (SM1592)	1. Check the communication setting in the master, and the communication setting in slave 29. 2. Check the communication cable.
16#9A5E	There is no response from slave 30 in the PLC Link. (SM1592)	1. Check the communication setting in the master, and the communication setting in slave 30. 2. Check the communication cable.
16#9A5F	There is no response from slave 31 in the PLC Link. (SM1592)	1. Check the communication setting in the master, and the communication setting in slave 31. 2. Check the communication cable.
16#9A60	There is no response from slave 32 in the PLC Link. (SM1592)	1. Check the communication setting in the master, and the communication setting in slave 32. 2. Check the communication cable.
16#9A61	The setting of the PLC Link mode is incorrect. (SM1589)	Make sure that SM1586 and SM1587 are not both ON.
16#9A62	The number of polling cycles in the PLC Link is incorrect. (SM1592)	If the PLC Link is in the manual mode, please make sure that the number of polling cycles is within the range between 1 and 65535.
16#9A63	There is a handshaking timeout when the CPU module establishes a connection with the network module. (SM1596)	Check whether the network module operates normally.
16#9A64	There is no network module parameter in the CPU module. (SM1596)	Download the parameter in HWCONFIG again.

9.2 Troubleshooting for I/O Modules

● Introduction of modules

Digital I/O modules, analog I/O modules, network modules, temperature measurement modules, and motion control modules can be installed in an AH500 system. Please refer to AH500 Module Manual for more information about the specifications for I/O modules. The error codes and the remedies for the errors are listed below.

9.2.1 Troubleshooting for Analog I/O Modules and Temperature Measurement Modules

Error code	Description	Remedy
16#A000	The signal received by channel 0 exceeds the range of inputs which can be received by the hardware. (The ERROR LED indicator blinks.)	Check the module parameter in HWCONFIG. Check whether the signal received by channel 0 exceeds the range of inputs which can be received by the hardware.
16#A001	The signal received by channel 1 exceeds the range of inputs which can be received by the hardware. (The ERROR LED indicator blinks.)	Check the module parameter in HWCONFIG. Check whether the signal received by channel 1 exceeds the range of inputs which can be received by the hardware.

Error code	Description	Remedy
16#A002	The signal received by channel 2 exceeds the range of inputs which can be received by the hardware. (The ERROR LED indicator blinks.)	Check the module parameter in HWCONFIG. Check whether the signal received by channel 2 exceeds the range of inputs which can be received by the hardware.
16#A003	The signal received by channel 3 exceeds the range of inputs which can be received by the hardware. (The ERROR LED indicator blinks.)	Check the module parameter in HWCONFIG. Check whether The signal received by channel 3 exceeds the range of inputs which can be received by the hardware.
16#A004	The signal received by channel 4 exceeds the range of inputs which can be received by the hardware. (The ERROR LED indicator blinks.)	Check the module parameter in HWCONFIG. Check whether The signal received by channel 4 exceeds the range of inputs which can be received by the hardware.
16#A005	The signal received by channel 5 exceeds the range of inputs which can be received by the hardware. (The ERROR LED indicator blinks.)	Check the module parameter in HWCONFIG. Check whether the signal received by channel 5 exceeds the range of inputs which can be received by the hardware.
16#A006	The signal received by channel 6 exceeds the range of inputs which can be received by the hardware. (The ERROR LED indicator blinks.)	Check the module parameter in HWCONFIG. Check whether the signal received by channel 6 exceeds the range of inputs which can be received by the hardware.
16#A007	The signal received by channel 7 exceeds the range of inputs which can be received by the hardware. (The ERROR LED indicator blinks.)	Check the module parameter in HWCONFIG. Check whether the input signal in channel 7 exceeds the specifications.
16#A400	The signal received by channel 0 exceeds the range of inputs which can be received by the hardware. (The ERROR LED indicator is ON.)	Check the module parameter in HWCONFIG. Check whether the signal received by channel 0 exceeds the range of inputs which can be received by the hardware.
16#A401	The signal received by channel 1 exceeds the range of inputs which can be received by the hardware. (The ERROR LED indicator is ON.)	Check the module parameter in HWCONFIG. Check whether the signal received by channel 1 exceeds the range of inputs which can be received by the hardware.
16#A402	The signal received by channel 2 exceeds the range of inputs which can be received by the hardware. (The ERROR LED indicator is ON.)	Check the module parameter in HWCONFIG. Check whether the signal received by channel 2 exceeds the range of inputs which can be received by the hardware.
16#A403	The signal received by channel 3 exceeds the range of inputs which can be received by the hardware. (The ERROR LED indicator is ON.)	Check the module parameter in HWCONFIG. Check whether the signal received by channel 3 exceeds the range of inputs which can be received by the hardware.

Error code	Description	Remedy
16#A404	The signal received by channel 4 exceeds the range of inputs which can be received by the hardware. (The ERROR LED indicator is ON.)	Check the module parameter in HWCONFIG. Check whether the signal received by channel 4 exceeds the range of inputs which can be received by the hardware.
16#A405	The signal received by channel 5 exceeds the range of inputs which can be received by the hardware. (The ERROR LED indicator is ON.)	Check the module parameter in HWCONFIG. Check whether The signal received by channel 5 exceeds the range of inputs which can be received by the hardware.
16#A406	The signal received by channel 6 exceeds the range of inputs which can be received by the hardware. (The ERROR LED indicator is ON.)	Check the module parameter in HWCONFIG. Check whether the signal received by channel 6 exceeds the range of inputs which can be received by the hardware.
16#A407	The signal received by channel 7 exceeds the range of inputs which can be received by the hardware. (The ERROR LED indicator is ON.)	Check the module parameter in HWCONFIG. Check whether the signal received by channel 7 exceeds the range of inputs which can be received by the hardware.
16#A600	Hardware failure	1. Check whether the backplane is normal. 2. Check whether the module operate normally.
16#A601	The external voltage is abnormal.	Check whether the external 24 V power supply to the module is normal.
16#A602	Internal error The CJC is abnormal.	Please contact the factory.
16#A603	Internal error The factory correction is abnormal.	Please contact the factory.
16#A800	The signal received by channel 0 exceeds the range of inputs which can be received by the hardware. (The ERROR LED indicator is OFF.)	Check the module parameter in HWCONFIG. Check whether the signal received by channel 0 exceeds the range of inputs which can be received by the hardware.
16#A801	The signal received by channel 1 exceeds the range of inputs which can be received by the hardware. (The ERROR LED indicator is OFF.)	Check the module parameter in HWCONFIG. Check whether the signal received by channel 1 exceeds the range of inputs which can be received by the hardware.
16#A802	The signal received by channel 2 exceeds the range of inputs which can be received by the hardware. (The ERROR LED indicator is OFF.)	Check the module parameter in HWCONFIG. Check whether the signal received by channel 2 exceeds the range of inputs which can be received by the hardware.
16#A803	The signal received by channel 3 exceeds the range of inputs which can be received by the hardware. (The ERROR LED indicator is OFF.)	Check the module parameter in HWCONFIG. Check whether the signal received by channel 3 exceeds the range of inputs which can be received by the hardware.
16#A804	The signal received by channel 4 exceeds the range of inputs which can be received by the hardware. (The ERROR LED indicator is OFF.)	Check the module parameter in HWCONFIG. Check whether the signal received by channel 4 exceeds the range of inputs which can be received by the hardware.

Error code	Description	Remedy
16#A805	The signal received by channel 5 exceeds the range of inputs which can be received by the hardware. (The ERROR LED indicator is OFF.)	Check the module parameter in HWCONFIG. Check whether the signal received by channel 5 exceeds the range of inputs which can be received by the hardware.
16#A806	The signal received by channel 6 exceeds the range of inputs which can be received by the hardware. (The ERROR LED indicator is OFF.)	Check the module parameter in HWCONFIG. Check whether the signal received by channel 6 exceeds the range of inputs which can be received by the hardware.
16#A807	The signal received by channel 7 exceeds the range of inputs which can be received by the hardware. (The ERROR LED indicator is OFF.)	Check the module parameter in HWCONFIG. Check whether the signal received by channel 7 exceeds the range of inputs which can be received by the hardware.

9.2.2 Troubleshooting for AH02HC-5A/AH04HC-5A

Error code	Description	Remedy
16#A001	The linear accumulation in channel 1 exceeds the range.	To clear the linear accumulation, users need to set bit 1 in CR0 to ON by means of FROM/TO.
16#A002	The prescale value for channel 1 exceeds the range.	Check the module parameter in HWCONFIG. The prescale value for channel 1 should be within the range between 0 and 32767.
16#A003	The moving average for channel 1 exceeds the range.	Check the module parameter in HWCONFIG. The moving average for channel 1 should be within the range between 2 and 60.
16#A004	The comparison value for channel 1 exceeds the range.	Check the module parameter in HWCONFIG. The comparison value for channel 1 should be within the range between -999999999 and 999999999.
16#A005	The limit value of the alarm output for channel 1 is incorrect.	Check the module parameter in HWCONFIG. The limit value of the alarm output for channel 1 should be within the range between -200000 and 200000.
16#A006	The interrupt number for channel 1 exceeds the range.	Check the module parameter in HWCONFIG. The interrupt number for channel 1 should be within the range between 0 and 31.
16#A011	The linear accumulation in channel 2 exceeds the range.	To clear the linear accumulation, users need to set bit 1 in CR28 to ON by means of FROM/TO.
16#A012	The prescale value for channel 2 exceeds the range.	Check the module parameter in HWCONFIG. The prescale value for channel 2 should be within the range between 0 and 32767.
16#A013	The moving average for channel 2 exceeds the range.	Check the module parameter in HWCONFIG. The moving average for channel 2 should be within the range between 2 and 60.
16#A014	The comparison value for channel 2 exceeds the range.	Check the module parameter in HWCONFIG. The comparison value for channel 2 should be within the range between -999999999 and 999999999.
16#A015	The limit value of the alarm output for channel 2 is incorrect.	Check the module parameter in HWCONFIG. The limit value of the alarm output for channel 2 should be within the range between -200000 and 200000.
16#A016	The interrupt number for channel 2 exceeds the range.	Check the module parameter in HWCONFIG. The interrupt number for channel 2 should be within the range between 0 and 31.

Error code	Description	Remedy
16#A021	The linear accumulation in channel 3 exceeds the range.	To clear the linear accumulation, users need to set bit 1 in CR56 to ON by means of FROM/TO.
16#A022	The prescale value for channel 3 exceeds the range.	Check the module parameter in HWCONFIG. The prescale value for channel 3 should be within the range between 0 and 32767.
16#A023	The moving average for channel 3 exceeds the range.	Check the module parameter in HWCONFIG. The moving average for channel 3 should be within the range between 2 and 60.
16#A024	The comparison value for channel 3 exceeds the range.	Check the module parameter in HWCONFIG. The comparison value for channel 3 should be within the range between -999999999 and 999999999.
16#A025	The limit value of the alarm output for channel 3 is incorrect.	Check the module parameter in HWCONFIG. The limit value of the alarm output for channel 3 should be within the range between -200000 and 200000.
16#A026	The interrupt number for channel 3 exceeds the range.	Check the module parameter in HWCONFIG. The interrupt number for channel 3 should be within the range between 0 and 31.
16#A031	The linear accumulation in channel 4 exceeds the range.	To clear the linear accumulation, users need to set bit 1 in CR84 to ON by means of FROM/TO.
16#A032	The prescale value for channel 4 exceeds the range.	Check the module parameter in HWCONFIG. The prescale value for channel 4 should be within the range between 0 and 32767.
16#A033	The moving average for channel 4 exceeds the range.	Check the module parameter in HWCONFIG. The moving average for channel 4 should be within the range between 2 and 60.
16#A034	The comparison value for channel 4 exceeds the range.	Check the module parameter in HWCONFIG. The comparison value for channel 4 should be within the range between -999999999 and 999999999.
16#A035	The limit value of the alarm output for channel 4 is incorrect.	Check the module parameter in HWCONFIG. The limit value of the alarm output for channel 4 should be within the range between -200000 and 200000.
16#A036	The interrupt number for channel 4 exceeds the range.	Check the module parameter in HWCONFIG. The interrupt number for channel 4 should be within the range between 0 and 31.

9.2.3 Troubleshooting for AH05PM-5A/AH10PM-5A/AH15PM-5A

The programs and the setting which are mentioned in the table below are edited in PMSOFT version 2.02 or above.

Error code	Description	Remedy
16#A002	The subroutine has no data.	A program should be written in the subroutine.
16#A003	CJ, CJN, and JMP have no matching pointers.	Write the pointers which match CJ, CJN, and JMP respectively.
16#A004	There is a subroutine pointer in the main program.	The subroutine pointer can not be in the main program.
16#A005	Lack of the subroutine	The nonexistent subroutine can not be called.
16#A006	The pointer is used repeatedly in the same program.	The pointer can not be used repeatedly in the same program.
16#A007	The subroutine pointer is used repeatedly.	The subroutine pointer can not be used repeatedly.
16#A008	The pointer used in JMP is used repeatedly in different subroutines.	The pointer used in JMP can not be used repeatedly in different subroutines.

Error code	Description	Remedy
16#A009	The pointer used in JMP is the same as the pointer used in CALL.	The pointer used in JMP can not be the same as the pointer used in CALL.
16#A00B	Target position (I) of the single speed is incorrect.	The target position (I) of the single speed should be set correctly.
16#A00C	Target position (II) of the single-axis motion is incorrect.	Check whether target position (II) of the single-axis motion and target position (I) of the single-axis motion are in opposite directions.
16#A00D	The setting of speed (I) of the single-axis motion is incorrect.	Set the speed of the single-axis motion.
16#A00E	The setting of speed (II) of the single-axis motion is incorrect.	The setting value can not be zero.
16#A00F	The setting of the speed (V_{RT}) of returning to zero is incorrect.	Set the speed of returning to zero properly. (The setting value can not be zero.)
16#A010	The setting of the deceleration (V_{CR}) of returning to zero is incorrect.	Set the speed of returning to zero. The deceleration should be less than the speed of returning to zero. (The setting value can not be zero.)
16#A011	The setting of the JOG speed is incorrect.	The setting value can not be zero.
16#A012	The positive pulses generated by the single-axis clockwise motion are inhibited.	The error occurs because the limit sensor is triggered. Check the status of the limit sensor, and check whether the motor operates normally.
16#A013	The negative pulses generated by the single-axis counterclockwise motion are inhibited.	The error occurs because the limit sensor is triggered. Check the status of the limit sensor, and check whether the motor operates normally.
16#A014	The limit switch is reached.	The error occurs because the limit sensor is triggered. Check the status of the limit sensor, and check whether the motor operates normally.
16#A015	The device which is used exceeds the device range.	Use the device which does not exceed the device range.
16#A017	An error occurs when the device is modified by a 16-bit index register/32-bit index register.	Use the 16-bit index register/32-bit index register which does not exceed the device range.
16#A018	The conversion into the floating-point number is incorrect.	Modify the operation to prevent the abnormal number from occurring.
16#A019	The conversion into the binary-coded decimal number is incorrect.	Modify the operation to prevent the abnormal number from occurring.
16#A01A	Incorrect division operation (The divisor is 0.)	Modify the operation to prevent the divisor from being zero.
16#A01B	General program error	Modify the program to make the syntax correct.
16#A01C	LD/LDI has been used more than nine times.	Modify the program to prevent LD/LDI from being used more than nine times.
16#A01D	There is more than one level of nested program structure supported by RPT/RPE.	Modify the program to prevent more than one level of nested program structure supported by RPT/RPE from being used.
16#A01E	SRET is used between RPT and RPE.	Modify the program to prevent SRET from being used between RPT and RPE.
16#A01F	There is no M102 in the main program, or there is no M2 in the motion program.	Modify the program so that there is M102 in the main program, or modify the program so that there is M2 in the motion program.
16#A020	The wrong instruction is used, or the device used exceeds the range.	Check and modify the program to prevent the wrong instruction from being used, or check whether the device used exceeds the device range.

9.2.4 Troubleshooting for AH20MC-5A

The programs and the setting which are mentioned in the table below are edited in PMSOFT version 2.02 or above.

Error code	Description	Remedy
16#A002	The subroutine has no data.	A program should be written in the subroutine.
16#A003	CJ, CJN, and JMP have no matching pointers.	Write the pointers which match CJ, CJN, and JMP respectively.
16#A004	There is a subroutine pointer in the main program.	The subroutine pointer can not be in the main program.
16#A005	Lack of the subroutine	The nonexistent subroutine can not be called.
16#A006	The pointer is used repeatedly in the same program.	The pointer can not be used repeatedly in the same program.
16#A007	The subroutine pointer is used repeatedly.	The subroutine pointer can not be used repeatedly.
16#A008	The pointer used in JMP is used repeatedly in different subroutines.	The pointer used in JMP can not be used repeatedly in different subroutines.
16#A009	The pointer used in JMP is the same as the pointer used in CALL.	The pointer used in JMP can not be the same as the pointer used in CALL.
16#A00B	Target position (I) of the single speed is incorrect.	The target position (I) of the single speed should be set correctly.
16#A00C	Target position (II) of the single-axis motion is incorrect.	Check whether target position (II) of the single-axis motion and target position (I) of the single-axis motion are in opposite directions.
16#A00D	The setting of speed (I) of the single-axis motion is incorrect.	Set the speed of the single-axis motion.
16#A00E	The setting of speed (II) of the single-axis motion is incorrect.	The setting value can not be zero.
16#A00F	The setting of the speed (V_{RT}) of returning to zero is incorrect.	Set the speed of returning to zero properly. (The setting value can not be zero.)
16#A010	The setting of the deceleration (V_{CR}) of returning to zero is incorrect.	Set the speed of returning to zero. The deceleration should be less than the speed of returning to zero. (The setting value can not be zero.)
16#A011	The setting of the JOG speed is incorrect.	The setting value can not be zero.
16#A012	The positive pulses generated by the single-axis clockwise motion are inhibited.	The error occurs because the limit sensor is triggered. Check the status of the limit sensor, and check whether the motor operates normally.
16#A013	The negative pulses generated by the single-axis counterclockwise motion are inhibited.	The error occurs because the limit sensor is triggered. Check the status of the limit sensor, and check whether the motor operates normally.
16#A014	The limit switch is reached.	The error occurs because the limit sensor is triggered. Check the status of the limit sensor, and check whether the motor operates normally.
16#A015	The device which is used exceeds the device range.	Use the device which does not exceed the device range.
16#A017	An error occurs when the device is modified by a 16-bit index register/32-bit index register.	Use the 16-bit index register/32-bit index register which does not exceed the device range.
16#A018	The conversion into the floating-point number is incorrect.	Modify the operation to prevent the abnormal number from occurring.
16#A019	The conversion into the binary-coded decimal number is incorrect.	Modify the operation to prevent the abnormal number from occurring.

Error code	Description	Remedy
16#A01A	Incorrect division operation (The divisor is 0.)	Modify the operation to prevent the divisor from being zero.
16#A01B	General program error	Modify the program to make the syntax correct.
16#A01C	LD/LDI has been used more than nine times.	Modify the program to prevent LD/LDI from being used more than nine times.
16#A01D	There is more than one level of nested program structure supported by RPT/RPE.	Modify the program to prevent more than one level of nested program structure supported by RPT/RPE from being used.
16#A01E	SRET is used between RPT and RPE.	Modify the program to prevent SRET from being used between RPT and RPE.
16#A01F	There is no M102 in the main program, or there is no M2 in the motion program.	Modify the program so that there is M102 in the main program, or modify the program so that there is M2 in the motion program.
16#A020	The wrong instruction is used, or the device used exceeds the range.	Check and modify the program to prevent the wrong instruction from being used, or check whether the device used exceeds the device range.

9.2.5 Troubleshooting for AH10EN-5A

Error code	Description	Remedy
16#A001	The IP address of host 1 conflicts with another system on the network.	1. Contact the network administrator, and check whether the IP address is correct. 2. Check the module parameter in HWCONFIG.
16#A002	The IP address of host 2 conflicts with another system on the network.	1. Contact the network administrator, and check whether the IP address is correct. 2. Check the module parameter in HWCONFIG.
16#A003	DHCP for host 1 fails.	Please contact the network administrator
16#A004	DHCP for host 2 fails.	Please contact the network administrator
16#A401	Hardware error	Please restore the hardware to the factory setting. If the error still occurs, please contact the factory.
16#A402	The initialization of the system fails.	Please restore the system to the factory setting. If the error still occurs, please contact the factory.

9.2.6 Troubleshooting for AH10SCM-5A

Error code	Description	Remedy
16#A002	The setting of the UD Link is incorrect, or the communication fails.	Check the setting in SCMSOFT, and download the setting again.
16#A401	Hardware error	Please contact the factory.
16#A804	The communication through the communication port is incorrect.	1. Check whether the communication cable is connected well. 2. Check the parameter in HWCONFIG, and the parameter. Download the parameter again.
16#A808	Modbus communication error	1. Check whether the communication cable is connected well. 2. Check the parameter in HWCONFIG, and the parameter. Download the parameter again.

9.2.7 Troubleshooting for AH10DNET-5A

The parameters which are mentioned in the table below are set in DeviceNet Builder version 1.07 or above.

Error code	Description	Remedy
16#A080	AH10DNET-5A stops running.	Switch the operating status of the CPU module to the running status.
16#A0E2	AH10DNET-5A functions as a master. The slave in the scan list is disconnected or does not exist.	<ol style="list-style-type: none"> 1. Check whether the node ID of the slave changes. 2. Check whether the communication cable is disconnected or loose. 3. Check whether the length of the cable is larger than the maximum transmission distance. If the length of the cable is larger than the maximum transmission distance, the stability of the system can not be ensured.
	AH10DNET-5A as a slave does not connect to the I/O module as a master.	<ol style="list-style-type: none"> 1. Check whether the node ID of the slave changes. 2. Check whether the communication cable is disconnected or loose. 3. Check whether the length of the cable is larger than the maximum transmission distance. If the length of the cable is larger than the maximum transmission distance, the stability of the system can not be ensured.
16#A0E7	AH10DNET-5A is checking whether its node ID is the same as the node ID of other device on the network.	<p>If the error has occurred for a long time, please eliminate the error in the following way.</p> <ol style="list-style-type: none"> 1. Make sure that there are at least two nodes working normally on the network. 2. Check whether the both ends of the cable are connected to 121 Ω terminal resistors. 3. Check whether the serial transmission speeds of other devices on the network are the same. 4. Check whether the communication cable is disconnected or loose. 5. Check whether the length of the communication cable is larger than the maximum transmission distance. If the length of the communication cable is larger than the maximum transmission distance, the stability of the system can not be ensured. 6. Check whether the shielded cable is grounded. 7. Supply power to AH10DNET-5A again.
16#A0E8	AH10DNET-5A is being initialized.	If the error has occurred for a long time, please supply power to the module again.
16#A0F0	The node ID of AH10DNET-5A is the same as other node ID on the network, or exceeds the range.	Make sure that the node ID of AH10DNET-5A is the only one on the network. If the node ID of AH10DNET-5A is not the only one on the network, please change the node ID, and supply power to AH10DNET-5 again.
16#A0F1	No slave is put on the scan list of AH10DNET-5A.	Put slaves on the scan list, and then download the scan list to AH10DNET-5A.
16#A0F2	The working voltage of AH10DNET-5A is low.	Check whether the working voltage of AH10DNET-5A and that of an AH500 series CPU module are normal.
16#A0F3	AH10DNET-5A enters the test mode.	Switch IN 1 on the module OFF, and supply power to AH10DNET-5A again.

Error code	Description	Remedy
16#A0F4	The bus of AH10DNET-5A becomes OFF.	<ol style="list-style-type: none"> 1. Check whether the communication cable is normal, and whether the shielded cable is grounded. 2. Check whether the serial transmission speeds of other devices on the network are the same. 3. Check whether the both ends of the cable are connected to 121 Ω terminal resistors. 4. Supply power to AH10DNET-5A again.
16#A0F5	AH10DNET-5A detects that there is no network power supply to the DeviceNet.	Check whether the communication cable is normal, and whether the network power supply is normal.
16#A0F6	Something is wrong with the internal memory of AH10DNET-5A.	Supply power to AH10DNET-5A again. If the error still occurs, please contact the factory.
16#A0F7	Something is wrong with the data exchange unit of AH10DNET-5A.	Supply power to AH10DNET-5A again. If the error still occurs, please contact the factory.
16#A0F8	The product ID of AH10DNET-5A is incorrect.	Supply power to AH10DNET-5A again. If the error still occurs, please contact the factory.
16#A0F9	An error occurs when the data is read from AH10DNET-5A, or when the data is written into AH10DNET-5A.	Supply power to AH10DNET-5A again. If the error still occurs, please contact the factory.
16#A0FA	The node ID of AH10DNET-5A is the same as that of the slave set in the scan list.	<ol style="list-style-type: none"> 1. Set the node ID of AH10DNET-5A again. The new node ID can not be the same as the node ID of the slave set in the scan list. Supply power to AH10DNET-5A again. 2. Put no slave in the scan list, and download the blank scan list to AH10DNET-5A through the simulated online mode in the software. Supply power to AH10DNET-5A again.

9.2.8 Troubleshooting for AH10PFBM-5A

Error code	Description	Remedy
16#A003	The master station enters the test mode.	Just repower it.
16#A005	A timeout occurs when chips inside the master station communicate.	Download the appropriate configuration again. If the error still occurs, please contact the factory.
16#A00B	A timeout occurs when AH10PFBM-5A exchanges data exchange with a PLC.	Repower AH10PFBM-5A . If the error still occurs, please contact the factory.
16#A0E2	AH10PFBM-5A detects that one slave is offline.	<ol style="list-style-type: none"> 1. Detect if the PROFIBUS-DP bus connection is proper. 2. Detect if both ends of the network have connected the terminal resistors respectively.
16#A0E6	The master station detects that an error occurs in a module connected to AHRTU-PFBS-5A.	Please check the modules connected to AHRTU-PFBS-5A.
16#A401	The configuration in the master module is empty.	Download the appropriate configuration.
16#A402	PLC does not assign the I/O mapping area to the master.	Assign the appropriate I/O mapping area to the master via ISPSOft.
16#A404	Master initializing error	Contact the factory if the error still exists after repowering AH10PFBM-5A.

Error code	Description	Remedy
16#A406	Internal storage unit error	Contact the factory if the error still exists after repowering AH10PFBS-5A.
16#A407	Data exchange unit error	Contact the factory if the error still exists after repowering AH10PFBS-5A.
16#A408	Master serial number detection error	Contact the factory if the error still exists after repowering AH10PFBS-5A.

9.2.9 Troubleshooting for AH10PFBS-5A

Error code	Description	Remedy
16#A0F0	The node address of AH10PFBS-5A exceeds the valid range.	Set the node address of AH10PFBS-5A between 1~125.
16#A4F1	Internal hardware error	If the error still exists after repowering AH10PFBS-5A, replace it with a new one.
16#A4F2	Parameter error	Check if the GSD file AH10PFBS-5A is using is correct.
16#A4F3	Configuration error	Check if the GSD file AH10PFBS-5A is using is correct.
16#A4F4	GPIO detection error	If the error still exists after repowering AH10PFBS-5A, replace it with a new one.
16#A4F5	AH10PFBS-5A enters the mode of factory test.	Repower AH10PFBS-5A after setting its node address between 1~125.
16#A4F6	<ol style="list-style-type: none"> AH10PFBS-5A has not been connected to the PROFIBUS-DP network. PROFIBUS-DP master has not configured AH10PFBS-5A slave or the configured node address of AH10PFBS-5A is inconsistent with that of the actually connected one. 	<ol style="list-style-type: none"> Check if the communication cable between AH10PFBS-5A and PROFIBUS-DP master is in normal status. Ensure that AH10PFBS-5A slave has been configured to PROFIBUS-DP master and the configured node address of AH10PFBS-5A is consistent with that of the actually connected one. Check if PROFIBUS-DP master works normally.

9.2.10 Troubleshooting for AH10COPM-5A

Error code	Description	Remedy
16#A0B0	AH10COPM-5A does not send a heartbeat message after a set period of time.	Check whether the bus cable on the CANopen network created is connected correctly.
16#A0B1	The length of a PDO that a slave station sends is not the same as the length of the PDO set in the node list.	Set the length of the PDO in the slave station again, and then download the setting to AH10COPM-5A.
16#A0B2	The master station selected does not send a node guarding message after a set period of time.	Check whether the bus cable on the CANopen network created is connected correctly.
16#A0E0	AH10COPM-5A receives an emergency message from a slave station.	Use the function block CANopen_EM CY to read relevant information.
16#A0E1	The length of a PDO that a slave station sends is not the	Set the length of the PDO in the slave station again, and then download the setting to AH10COPM-5A.

Error code	Description	Remedy
	same as the length of the PDO set in the node list.	
16#A0E2	AH10COPM-5A does not receive a PDO from a slave station.	Make sure that the PDOs in the slave station are set correctly.
16#A0E3	An automatic SDO is not downloaded successfully.	Make sure that the automatic SDO is set correctly.
16#A0E4	A PDO parameter is not set successfully.	Make sure that the setting of the PDO parameter is legal.
16#A0E5	A key parameter is set incorrectly.	Make sure that the slave stations connected are the same as the slave stations set.
16#A0E6	The actual network configuration is not the same as the network configuration set.	Make sure that the power supplied to the slave stations connected is normal and the network created is connected correctly.
16#A0E7	The control of the errors in a slave station is not sent after a set period of time.	
16#A0E8	The master station address is the same as a slave station address.	Set the master station address or the slave station address again, and make sure the new station address is not the same as a slave station address.
16#A0F1	No slave station is added to the node list in CANopen builder.	Add slave stations to the node list, and download the configuration to AH10COPM-5A.
16#A0F3	An error occurs in AH10COPM-5A.	Download parameters again. If the error still occurs, please replace AH10COPM-5A.
16#A0F4	The bus used is off.	Please check whether the bus cable on the CANopen network created is connected correctly, make sure that the serial transmission speeds of all the nodes on the network are the same, and power AH10COPM-5A again.
16#A0F5	The node address of AH10COPM-5A is set incorrectly.	The node address of AH10COPM-5A must be in the range of 1 to 127.
16#A0F6	Internal error: An error occurs in the manufacturing process in the factory.	Power AH10COPM-5A again. If the error still occurs, please replace AH10COPM-5A.
16#A0F7	Internal error: GPIO error	
16#A0F8	Hardware error	
16#A0F9	Low voltage	Make sure that the power supplied to AH10COPM-5A is normal.
16#A0FA	An error occurs in the firmware of AH10COPM-5A.	Power AH10COPM-5A again.
16#A0FB	The transmission registers in AH10COPM-5A are full.	Please make sure that the bus cable on the CANopen network created is connected correctly, and power AH10COPM-5A again.
16#A0FC	The reception registers in AH10COPM-5A are full.	Please make sure that the bus cable on the CANopen network created is connected correctly, and power AH10COPM-5A again.

MEMO