

Compact magnetic cylinders Series 32

Single and double-acting, non-rotating
 \varnothing 20, 25, 32, 40, 50, 63, 80, 100.

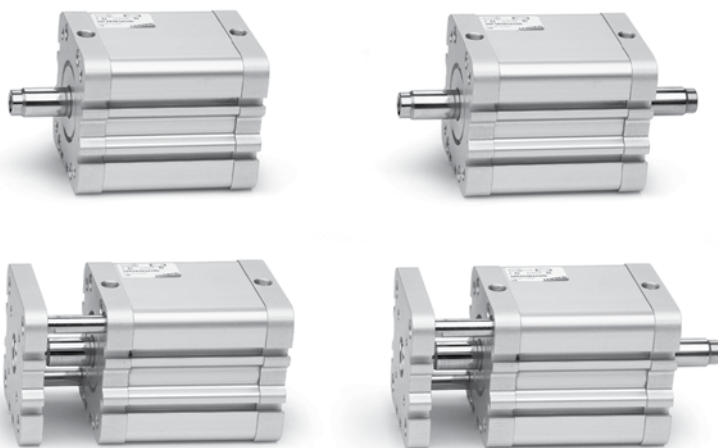

- » Compact design
- » Wide variety of models available in different diameters
- » In compliance with ISO 21287

Series 32 cylinders, thanks to their compactness, are suitable for installation in confined spaces. Being in compliance with the ISO 21287 Standard, the cylinders Series 32 have the advantage that they can be used in conjunction with mountings/accessories suitable for other standard cylinders DIN/ISO 6431 / VDMA 24562 (Series 60/61).

GENERAL DATA

Construction	compact profile
Operation	single and double acting, magnetic
Materials	body and end-blocks = anodized AL rod = rolled stainless steel AISI 303 piston = AL rod seal, OR end-block and piston seal = PU high temperatures: rod seal, OR end-block and piston in FKM (140°)
Mounting	with threaded holes on the end blocks flange - feet - trunnion
Stroke min and max (1)	Series 32F, 32M, 32R \varnothing 20-25 = 5-300 mm Series 32F, 32M, 32R \varnothing 32-40-50-63 = 5-400 mm Series 32F, 32M, 32R \varnothing 80-100 = 5-500 mm
Operating temperature	0°C + 80°C (with dry air -20°C)
Operating pressure	1 + 10 bar (double-acting) / 2+10 bar (single-acting)
Fluid	clean air without lubrication. If lubricated air is used it is recommended to use oil ISOVG32. Once applied the lubrication should never be interrupted.
Operation speed	10 + 1000mm/sec. (without load)

(1) the minimum stroke for the use of the sensors is 10 mm.

STANDARD STROKES FOR CYLINDERS SERIES 32

✕= Non-rotating ●= Double-acting, male/female rod thread;
■= Single-acting, front/rear spring, male/female rod thread.

∅	5	10	15	20	25	30	40	50	60	80
20	✕●■	✕●■	✕●■	✕●■	✕●■	✕●	✕●	✕●		
25	✕●■	✕●■	✕●■	✕●■	✕●■	✕●	✕●	✕●		
32	✕●■	✕●■	✕●■	✕●■	✕●■	✕●	✕●	✕●	✕●	✕●
40	✕●■	✕●■	✕●■	✕●■	✕●■	✕●	✕●	✕●	✕●	✕●
50		✕●■	✕●■	✕●■	✕●■	✕●	✕●	✕●	✕●	✕●
63		✕●■	✕●■	✕●■	✕●■	✕●	✕●	✕●	✕●	✕●
80		✕●■	✕●■	✕●■	✕●■	✕●	✕●	✕●	✕●	✕●
100		✕●■	✕●■	✕●■	✕●■	✕●	✕●	✕●	✕●	✕●

CODING EXAMPLE

32	M	2	A	032	A	050	
----	---	---	---	-----	---	-----	--

32	SERIES	
M	VERSION M = male thread F = female thread R = antirotation with flange (not for single-acting version)	
2	OPERATION 1 = single-acting, front spring 2 = double-acting 3 = double-acting, through-rod 4 = single-acting, rear spring	PNEUMATIC SYMBOLS CS06 CD08 CD12 CS08
A	MATERIALS A = anodized aluminium body, end blocks and piston, PU seals (rod, OR end block and piston)	
032	BORES 020 = 20 mm - 025 = 25 mm - 032 = 32 mm - 040 = 40 mm 050 = 50 mm - 063 = 63 mm - 080 = 80 mm - 100 = 100 mm	
A	CONSTRUCTION A = standard	
050	STROKE (see the table) = standard S = special V = FKM rod seal W = high temperatures (double-acting, non-magnetic with FKM seals for high temperatures up to 140°C)	

PNEUMATIC SYMBOLS

The pneumatic symbols which have been indicated in the CODING EXAMPLE are shown below.

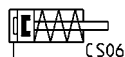
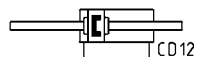
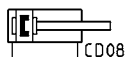

ACCESSORIES FOR CYLINDERS SERIES 32
1

MOVEMENT

 Piston rod socket joint
Mod. GY

 Piston rod lock nut Mod.
U

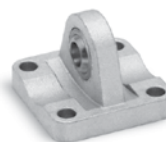

Clevis pin Mod. S

 Rear trunnion ball-joint
Mod. R

 Coupling piece Mod.
GKF

Swivel ball joint Mod. GA

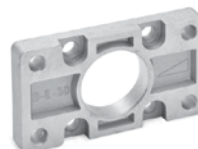

 90° male trunnion Mod.
ZC

 Swivel combination Mod.
C+L+S

 Front and rear flange
Mod. D-E

 Self aligning rod Mod.
GK

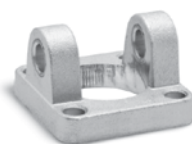
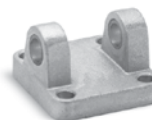
 90° swivel combination
for trunnion Mod. I

Foot mount Mod. B

 Front female trunnion
Mod. H and C-H

 Rear female trunnion
Mod. C and C-H

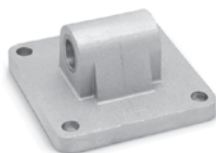

Rod fork end Mod. G

 Rear trunnion male
Mod. L

All accessories are supplied separately.

APPLICABLE LOADS

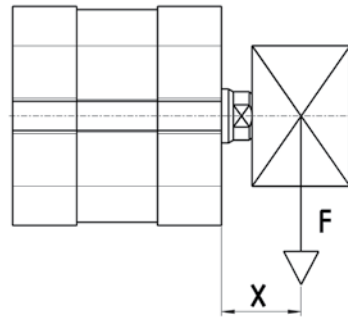
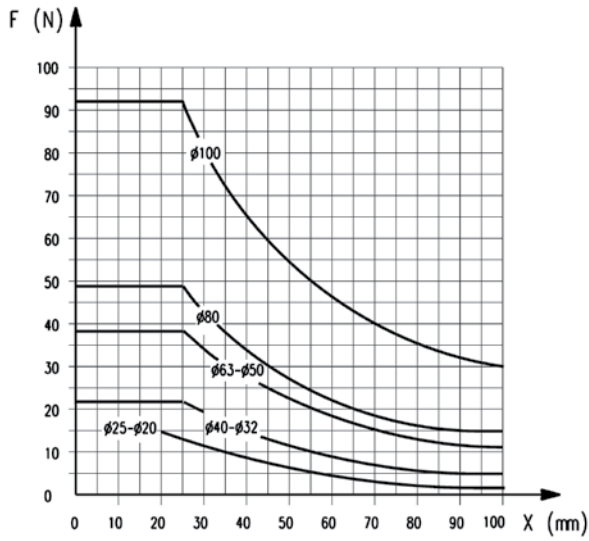
1
MOVEMENT



Standard.
Transversal load (F) dependant on stroke (X)

APPLICABLE LOADS

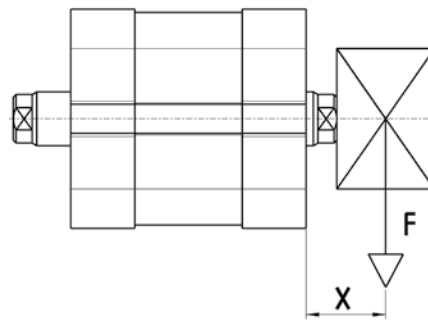
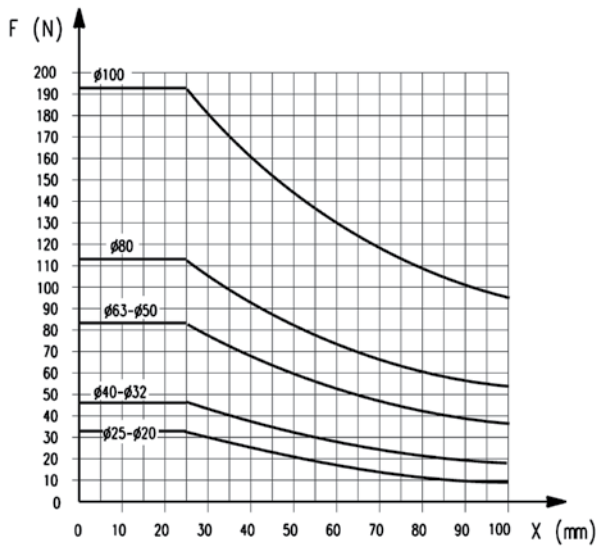

Through-rod.
Transversal load (F) dependant on stroke (X)

APPLICABLE LOADS

1

MOVEMENT

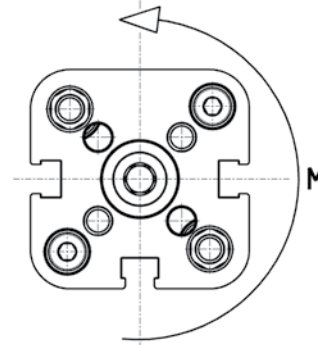
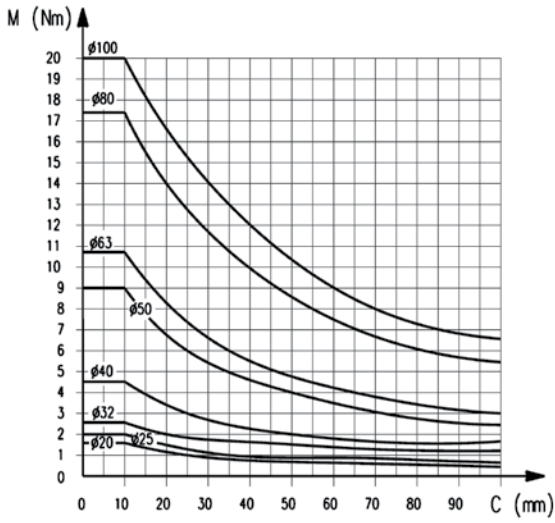

It is possible to use longer strokes as indicated in the general data (excluding radial loads and torque moments). When imposing radial loads on the cylinder it is important to respect the maximum stroke of the centre of gravity. In the presence of torque moments, respect the maximum stroke as shown in the diagrams.

Torque moment (M) dependant on stroke (C).

APPLICABLE LOADS

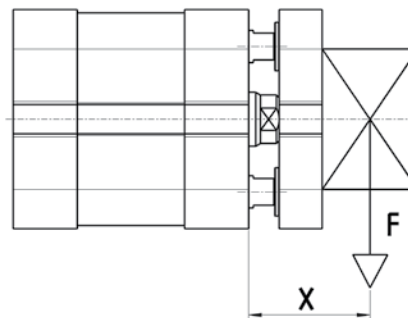
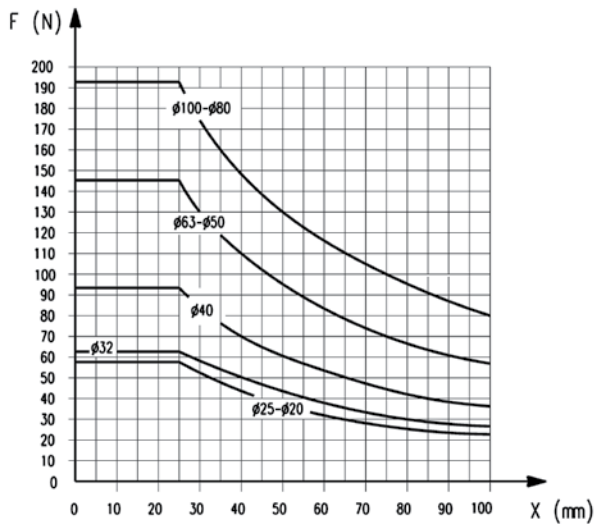

Anti-rotation.
Transversal load (F) dependant on stroke (X).

APPLICABLE LOADS

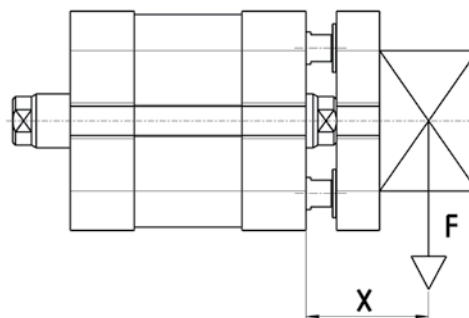
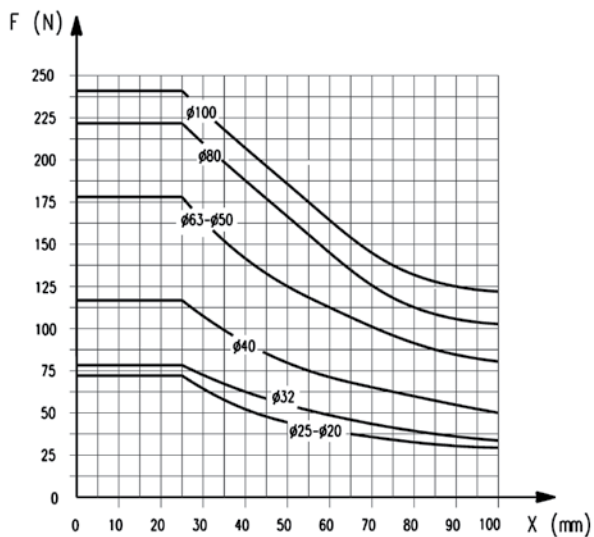

Anti-rotation through-rod.
Transversal load (F) dependant on stroke (X).

MOUNTING EXAMPLE

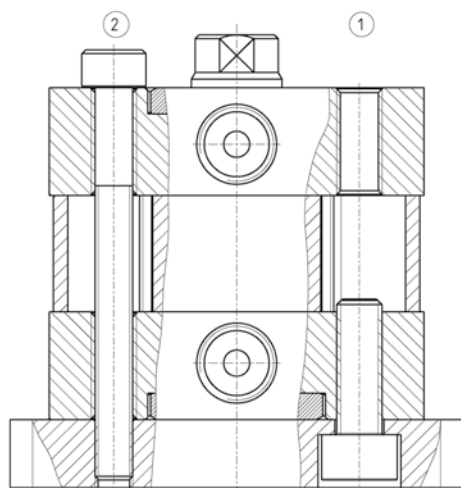

Mounting example for mounting cylinders Ø 32; 40; 50; 63; 80; 100.
1 = Rear mounting
2 = Through mounting

N.B. For through mounting with screws through the cylinder it is recommended to use non-magnetic screws.

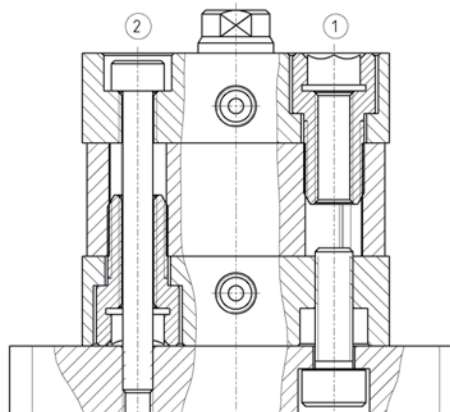

Mounting example for mounting cylinders Ø 20 ÷ 25.
1 = Rear mounting
2 = Through mounting

N.B. For through mounting with screws through the cylinder it is recommended to use non-magnetic screws.

Compact magnetic cylinders Mod. 32F and 32M



+ = add the stroke
1 = groove for sensor

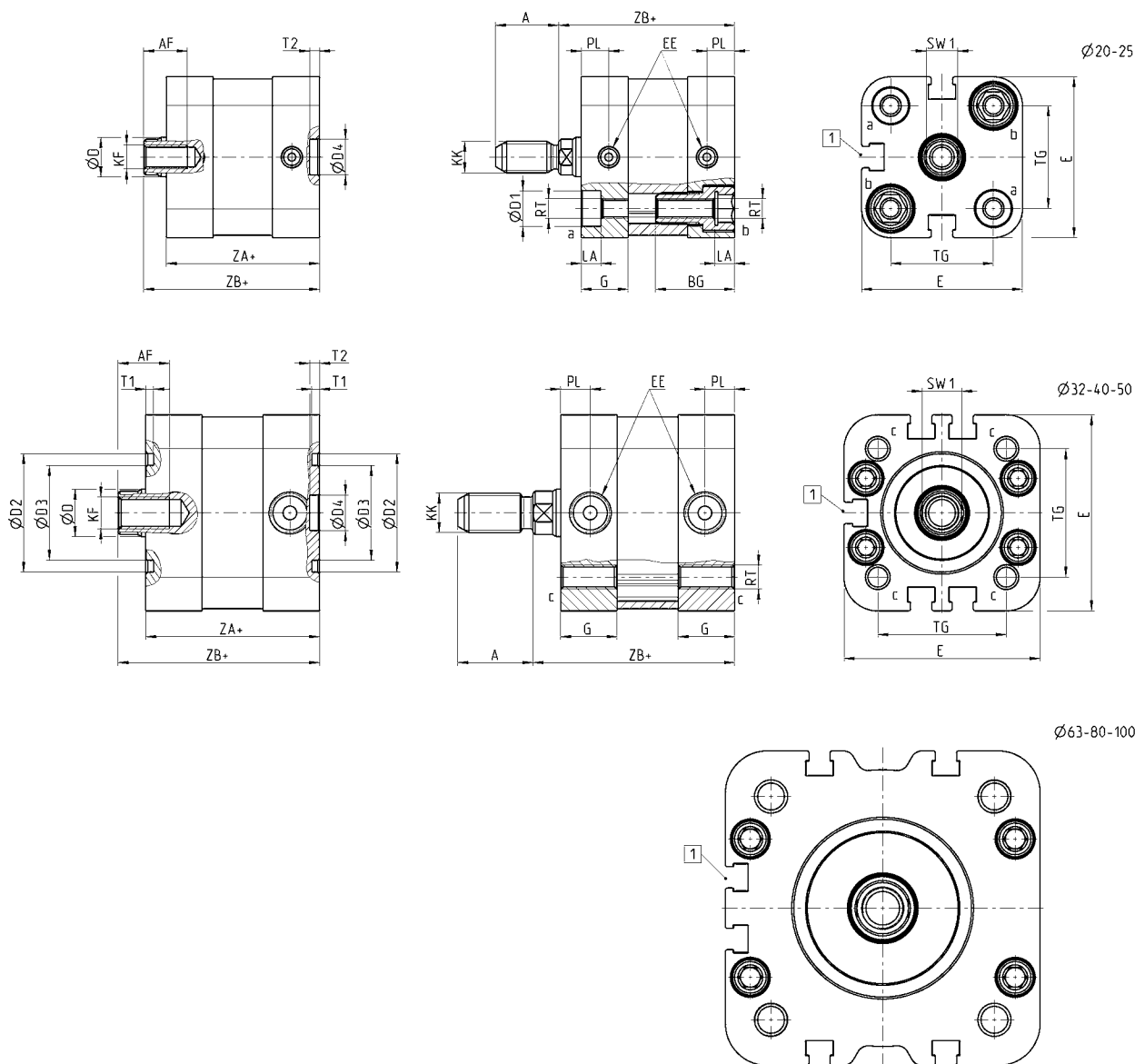

DIMENSIONS

Ø	A	AF	BG	G	ØD	D1	ØD2	ØD3	ØD4	E	EE	KF	KK	LA	PL	RT	SW1	T1	T2	TG	ZA	ZB
20	16	11	20	10,9	10	9	-	-	9	35,8	M5	M6	M8X1,25	5	6,5	M5	8	-	2,5	22	36,8	42,5
25	16	11	20	11,9	10	9	-	-	9	40,7	M5	M6	M8X1,25	5	7	M5	8	-	2,5	26	38,8	44,5
32	19	13	-	14,3	12	-	30	24	9	49,6	G1/8	M8	M10X1,25	-	7,6	M6	10	2	2,5	32,5	44	51
40	19	13	-	14,3	12	-	35	29	9	57	G1/8	M8	M10X1,25	-	7,6	M6	10	2	2,5	38	45	52
50	22	16	-	14,3	16	-	40	34	12	69,6	G1/8	M10	M12X1,25	-	7,6	M8	13	2	3	46,5	45	53
63	22	16	-	14	16	-	45	39	12	79,6	G1/8	M10	M12X1,25	-	7,6	M8	13	2	3	56,5	49	57
80	28	20	-	14,8	20	-	45	39	12	95,6	G1/8	M12	M16X1,5	-	7,7	M10	17	2	3	72	54	63,5
100	28	20	-	17,8	25	-	55	49	12	115,6	G1/8	M12	M16X1,5	-	8	M10	22	2	3	89	66,8	76,5

Compact magnetic cylinders Mod. 32F3 and 32M3



+ = add the stroke
 ++ = add the stroke two times
 1 = groove for sensor

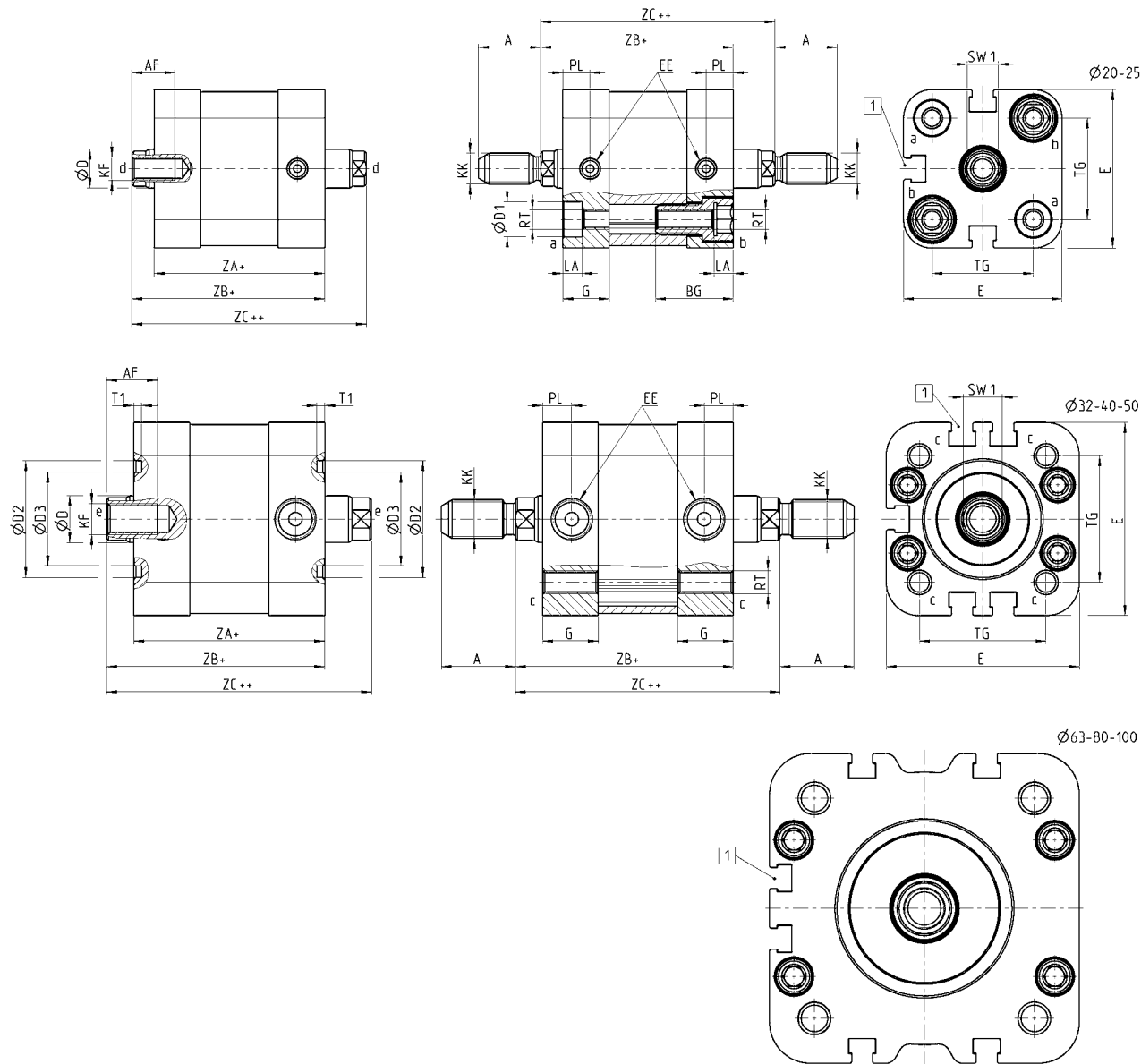

DIMENSIONS																					
Ø	A	AF	BG	G	ØD	ØD1	ØD2	ØD3	E	EE	KF	KK	LA	PL	RT	SW1	T1	TG	ZA	ZB	ZC
20	16	11	20	10,9	10	9	-	-	35,8	M5	M6	M8X1,25	5	6,5	M5	8	-	22	36,8	42,5	48,2
25	16	11	20	11,9	10	9	-	-	40,7	M5	M6	M8X1,25	5	7	M5	8	-	26	38,8	44,5	50,2
32	19	13	-	14,3	12	-	30	24	49,6	G1/8	M8	M10X1,25	-	7,6	M6	10	2	32,5	44	51	58
40	19	13	-	14,3	12	-	35	29	57	G1/8	M8	M10X1,25	-	7,6	M6	10	2	38	45	52	59
50	22	16	-	14,3	16	-	40	34	69,6	G1/8	M10	M12X1,25	-	7,6	M8	13	2	46,5	45	53	61
63	22	16	-	14	16	-	45	39	79,6	G1/8	M10	M12X1,25	-	7,6	M8	13	2	56,5	49	57	65
80	28	20	-	14,8	20	-	45	39	95,6	G1/8	M12	M16X1,5	-	7,7	M10	17	2	72	54	63,5	73
100	28	20	-	17,8	25	-	55	49	115,6	G1/8	M12	M16X1,5	-	8	M10	22	2	89	66,8	76,5	86,2

The company reserves the right to vary models and dimensions without notice.
 Products designed for industrial applications. Sale to general public is forbidden.

Compact magnetic cylinders Mod. 32R

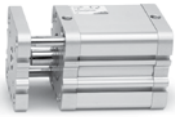

+ = add the stroke
 ++ = add the stroke two times
 1 = groove for sensor

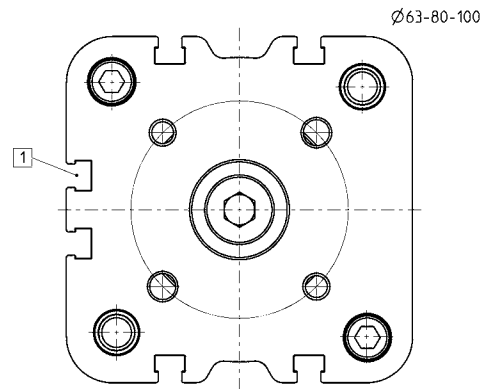
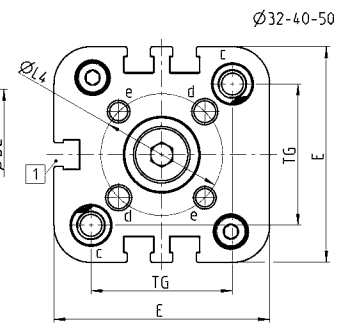
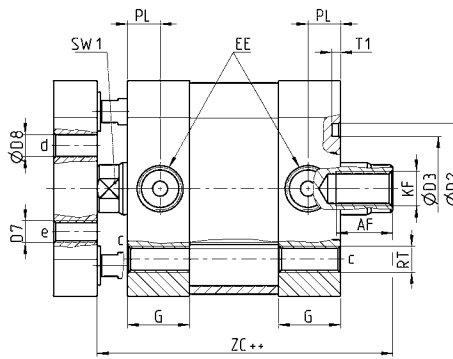
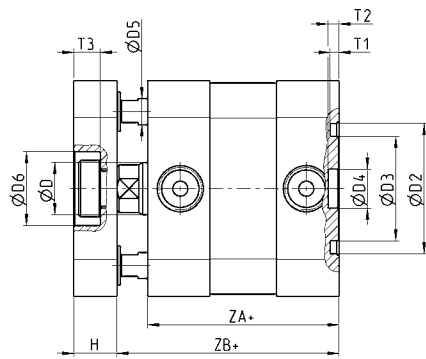
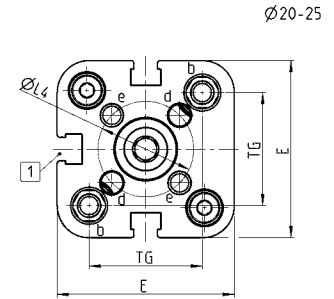
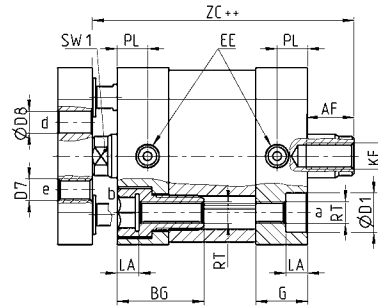
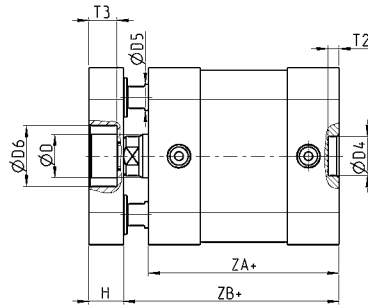

DIMENSIONS

Ø	AF	BG	G	ØD	ØD1	ØD2	ØD3	ØD4	ØD5	ØD6	D7	ØD8	E	EE	H	KF	LA	ØL4	PL	RT	SW1	T1	T2	T3	TG	ZA	ZB	ZC
20	11	20	10,9	10	9	-	-	9	6	-	M4	4	35,8	M5	8	M6	5	17	6,5	M5	8	-	2,5	-	22	36,8	42,5	48,2
25	11	20	11,9	10	9	-	-	9	6	14	M5	5	40,7	M5	8	M6	5	22	7	M5	8	-	2,5	6,5	26	38,8	44,5	50,2
32	13	-	14,3	12	-	30	24	9	6	17	M5	5	49,6	G1/8	10	M8	-	28	7,6	M6	10	2	2,5	6	32,5	44	51	58
40	13	-	14,3	12	-	35	29	9	6	17	M5	5	57	G1/8	10	M8	-	33	7,6	M6	10	2	2,5	6	38	45	52	59
50	16	-	14,3	16	-	40	34	12	10	22	M6	6	69,6	G1/8	12	M10	-	42	7,6	M8	13	2	3	7	46,5	45	53	61
63	16	-	14	16	-	45	39	12	10	22	M6	6	79,6	G1/8	12	M10	-	50	7,6	M8	13	2	3	7	56,5	49	57	65
80	20	-	14,8	20	-	45	39	12	12	24	M8	8	95,6	G1/8	14	M12	-	65	7,7	M10	17	2	3	10,5	72	54	63,5	73
100	20	-	18	25	-	55	49	12	12	24	M10	10	115,6	G1/8	14	M12	-	80	8	M10	22	2	3	10,5	89	66,8	77,5	86,2

Foot mount Mod. B

Material: zinc-plated steel.



Supplied with:
2x feet
4x screws
+ = add the stroke

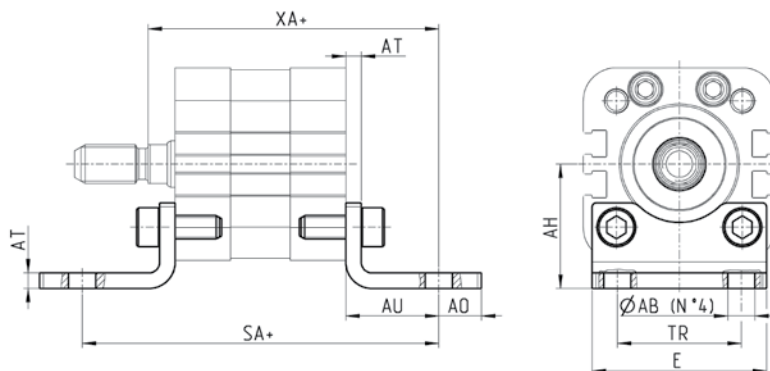

DIMENSIONS										
Mod.	Ø	øAB	AH	AO	AU	AT	E	TR	SA	XA
B-32-20	20	6,5	27	9	16	4	35	22	68,8	58,5
B-31-25	25	6,5	29	9	16	4	39	26	70,8	60,5
B-41-32	32	7	32	11	24	4	45	32	92	75
B-41-40	40	10	36	15	28	4	53,5	36	101	80
B-41-50	50	10	45	15	32	4	62,5	45	109	85
B-41-63	63	10	50	15	32	5	73	50	113	89
B-41-80	80	12	63	20	41	6	92	63	136	104,5
B-41-100	100	14,5	71	25	41	6	108,5	71	148,8	117,5

Rear female trunnion Mod. C and C-H

Material: Aluminium.



Supplied with:
1x female trunnion
4x screws
+ = add the stroke

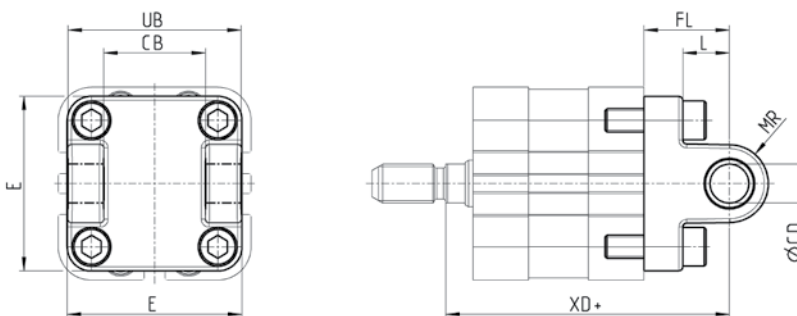

DIMENSIONS									
Mod.	Ø	øCD	E	CB	UB	L	FL	MR	XD
C-41-32	32	10	45	26	45	12	22	10	73
C-41-40	40	12	53,5	28	52	15	25	12	77
C-41-50	50	12	62,5	32	60	15	27	13	80
C-H-41-63	63	16	73	40	70	20	32	17	89
C-H-41-80	80	16	92	50	90	24	36	17	99,5
C-H-41-100	100	20	108,5	60	110	29	41	21	117,5

Front female trunnion Mod. H and C-H

Material: Aluminium.

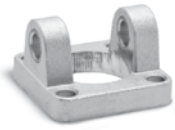
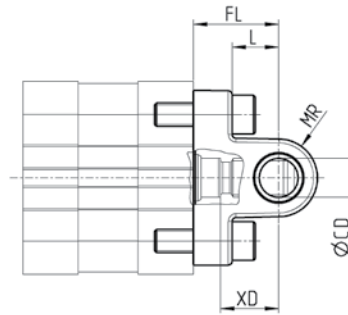
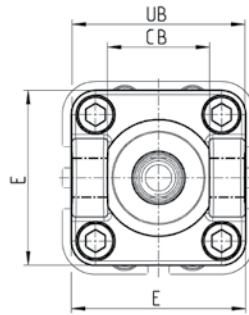
 Supplied with:
 1x female trunnion
 4x screws

DIMENSIONS

Mod.	Ø	ØCD	E	CB	UB	L	FL	MR	XD
H-41-32	32	10	45	26	45	12	22	10	15
H-41-40	40	12	53,5	28	52	15	25	12	18
H-41-50	50	12	62,5	32	60	15	27	13	19
H-80-63	63	16	73	40	70	20	32	17	24
C-H-41-80	80	16	92	50	90	24	36	17	26,5
C-H-41-100	100	20	108,5	60	110	29	41	21	31,3

Front and rear flange Mod. D-E

Material: zinc-plated steel for Ø 20 - Ø 25; Aluminium for Ø 32 ÷ Ø 100.

 Supplied with:
 1x flange
 4x screws

+ = add the stroke

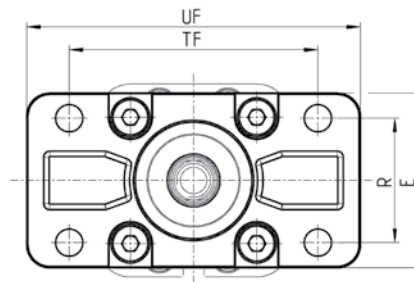
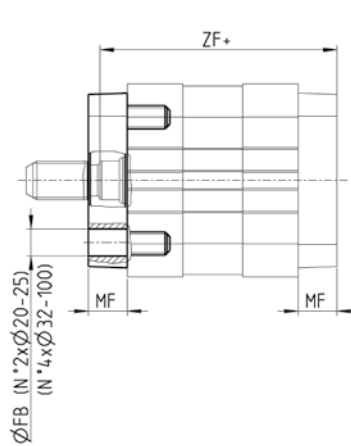
DIMENSIONS

Mod.	Ø	ØFB	E	MF	R	TF	UF	ZF
D-E-32-20	20	6,6	36	10	-	55	70	52,5
D-E-32-25	25	6,6	40	10	-	60	76	54,5
D-E-41-32	32	7	45	10	32	64	86	61
D-E-41-40	40	9	52	10	36	72	88	62
D-E-41-50	50	9	63	12	45	90	110	65
D-E-41-63	63	9	73	12	50	100	116	69
D-E-41-80	80	12	95	16	63	126	148	79,5
D-E-41-100	100	14	115	16	75	150	176	92,5

Rear trunnion male Mod. L

Material: Aluminium.

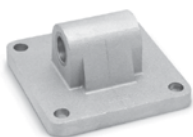

Supplied with:
1x male trunnion
4x screws

+ = add the stroke

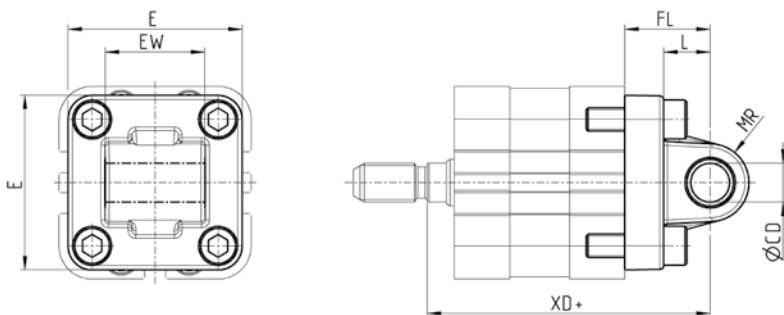

DIMENSIONS								
Mod.	Ø	ØCD	E	EW	L	FL	MR	XD
L-32-20	20	8	34	16	14	20	8	62,5
L-32-25	25	8	38	16	14	20	8	64,5
L-41-32	32	10	45	26	12	22	10	73
L-41-40	40	12	53,5	28	15	25	13	77
L-41-50	50	12	62,5	32	15	27	13	80
L-41-63	63	16	73	40	20	32	17	89
L-41-80	80	16	92	50	24	36	17	99,5
L-41-100	100	20	108,5	60	29	41	21	117,5

Rear trunnion ball-joint Mod. R

Material: Aluminium.

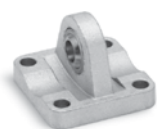

Supplied with:
1x ball joint
4x screws

+ = add the stroke

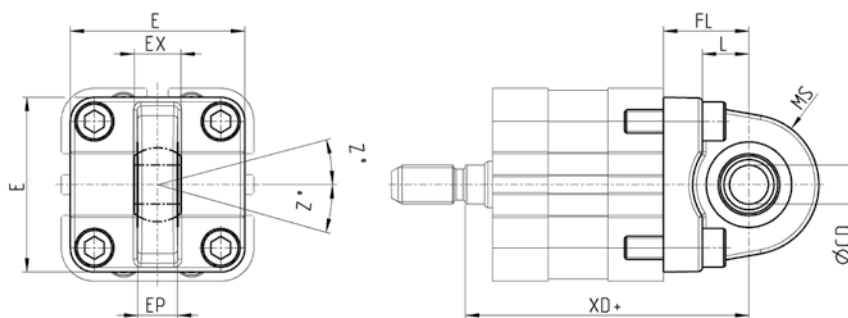

DIMENSIONS										
Mod.	Ø	ØCD	E	EX	EP	L	FL	MS	XD	Z°
R-41-32	32	10	45	14	10,5	12	22	18	73	4
R-41-40	40	12	53,5	16	12	15	25	18	77	4
R-41-50	50	12	62,5	16	12	15	27	21	80	4
R-41-63	63	16	73	21	15	20	32	23	89	5
R-41-80	80	16	92	21	15	24	36	36	99,5	5
R-41-100	100	20	108,5	25	18	29	41	41	117,5	5

Accessory combination Mod. C+L+S

Material: Aluminium.

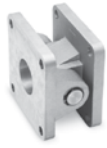

+ = add the stroke

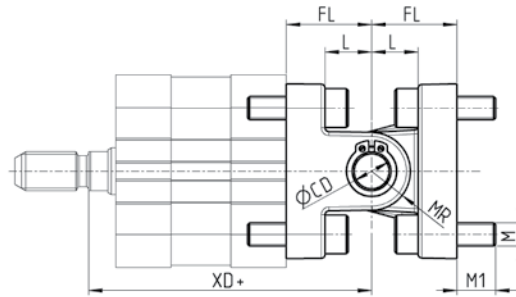
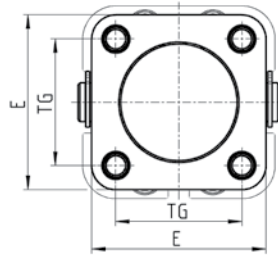
DIMENSIONS

Mod.	∅	∅CD	E	L	FL	M	M1	MR	TG	XD
C+L+S	32	10	45	12	22	M6	10	10	32,5	73
C+L+S	40	12	53,5	15	25	M6	10	12	38	77
C+L+S	50	12	62,5	15	27	M8	13	13	46,5	80
C+L+S	63	16	73	20	32	M8	13	17	56,5	89
C+L+S	80	16	92	24	36	M10	16	17	72	99,5
C+L+S	100	20	108,5	29	41	M10	16	21	89	117,5

90° male trunnion Mod. ZC

Material: Aluminium.

 Supplied with:
1x male support

+ = add the stroke

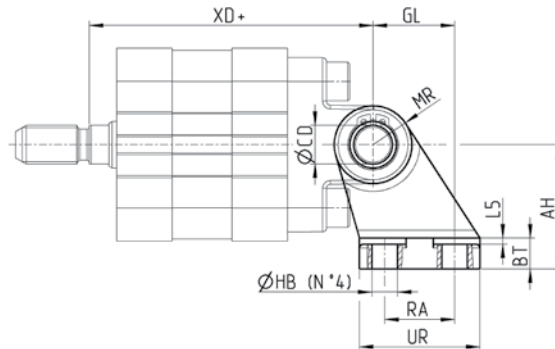
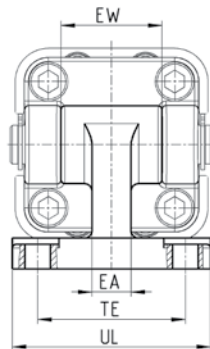
DIMENSIONS

Mod.	∅	AH	BT	∅CD	EA	EW	GL	∅HB	L5	MR	RA	UL	UR	TE	XD
ZC-32	32	32	8	10	10	26	21	6,6	1,6	10	18	51	31	38	73
ZC-40	40	36	10	12	15	28	24	6,6	1,6	11	22	54	35	41	77
ZC-50	50	45	12	12	16	32	33	9	1,6	13	30	65	45	50	80
ZC-63	63	50	14	16	16	40	37	9	1,6	15	35	67	50	52	89
ZC-80	80	63	14	16	20	50	47	11	2,5	15	40	86	60	66	99,5
ZC-100	100	71	17	20	20	60	55	11	2,5	19	50	96	70	76	117,5

90° swivel combination for trunnion Mod. I

Material: zinc-plated steel.



Supplied with:
1x female support
2x seeger
1x clevis pin

+ = add the stroke

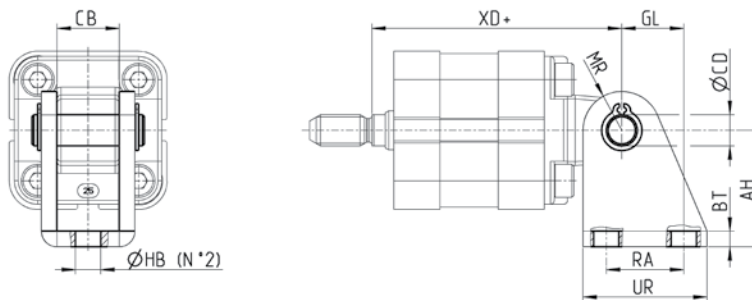

DIMENSIONS											
Mod.	Ø	AT	BT	ØCD	CB	GL	ØHB	MR	RA	UR	XD
I-20-25	20	30	4	8	16,1	16	6,5	10	20	32	62,5
I-20-25	25	30	4	8	16,1	16	6,5	10	20	32	64,5

Clevis pin Mod. S



Supplied with:
1x clevis pin (stainless steel)
2x Seeger (steel)

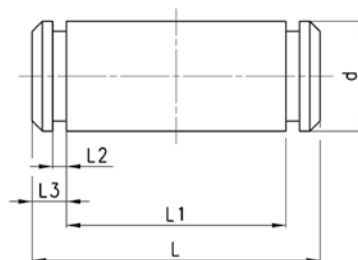

DIMENSIONS						
Mod.	Ø	D	L	L1	L2	L3
S-32	32	10	52	46	1,1	3
S-40	40	12	59	53	1,1	3
S-50	50	12	67	61	1,1	3
S-63	63	16	77	71	1,1	3
S-80	80	16	97	91	1,1	3
S-100	100	20	121	111	1,3	5

Rod fork end Mod. G

Material: zinc-plated steel ISO 8140.

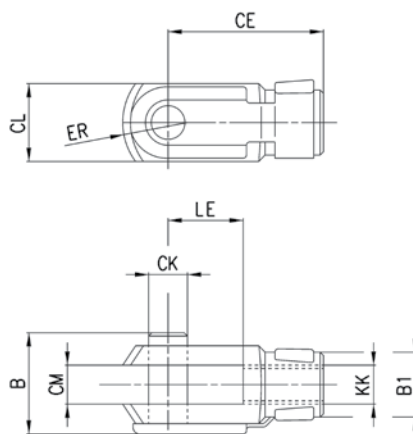
DIMENSIONS

Mod.	∅	∅CK	LE	CM	CL	ER	CE	KK	B	∅B1
G-20	20-25	8	16	8	16	10	32	M8X1,25	22	14
G-25-32	32-40	10	20	10	20	12	40	M10x1,25	26	18
G-40	50-63	12	24	12	24	14	48	M12x1,25	32	20
G-50-63	80-100	16	32	16	32	19	64	M16x1,5	40	26

Piston rod socket joint Mod. GY

Material: zinc-plated steel and zama.

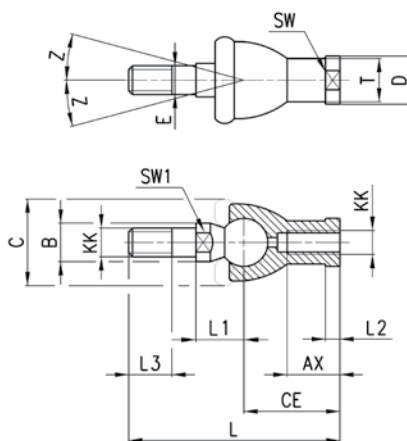
DIMENSIONS

Mod.	∅	KK	L	CE	L2	AX	SW	SW1	L1	L3	∅T	∅D	E	∅B	∅C	Z
GY-20	20-25	M8X1,25	65	32	5	16	14	10	16	12	12,5	13	6	10	20	15
GY-32	32-40	M10X1,25	74	35	6,5	18	17	11	19,5	15	15	19	10	14	28	15
GY-40	50-63	M12X1,25	84	40	6,5	20	19	17	21	17	17,5	22	12	19	32	15
GY-50-63	80-100	M16X1,5	112	50	8	27	22	19	27,5	23	22	27	16	22	40	11

Swivel ball joint Mod. GA

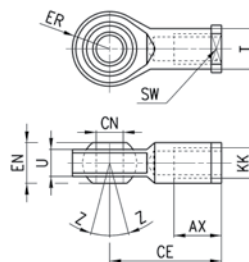

DIMENSIONS											
Mod.	\varnothing	\varnothing_{CN}	U	EN	ER	AX	CE	KK	$\varnothing T$	Z	SW
GA-20	20-25	8	9	12	12	16	36	M8X1,25	12,5	6,5	14
GA-32	32-40	10	10,5	14	14	20	43	M10x1,25	15	6,5	17
GA-40	50-63	12	12	16	16	22	50	M12X1,25	17,5	6,5	19
GA-50-63	80-100	16	15	21	21	28	64	M16x1,5	22	7,5	22

Piston rod lock nut Mod. U

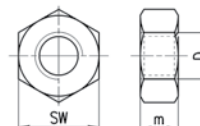

DIMENSIONS				
Mod.	\varnothing	D	M	SW
U-20	20-25	M8X1,25	5	13
U-25-32	32-40	M10X1,25	6	17
U-40	50-63	M12X1,25	7	19
U-50-63	80-100	M16X1,5	8	24

Centring sleeve Mod. TR

Designed for the centring of both the rear and front end caps with brackets Mod. B/D-E/C/C-H/H/L/R, as for the centring of the cylinder while mounting.



Material: anodized AL

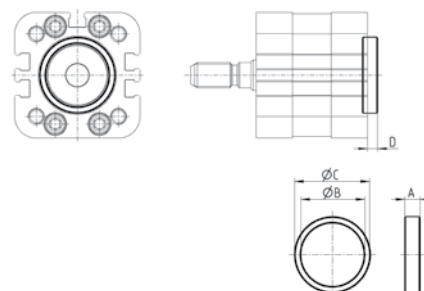

DIMENSIONS					
Mod.	\varnothing	A	$\varnothing B$	$\varnothing C$	D
TR-32-32	32	6	25	30	4
TR-32-40	40	6	30	35	4
TR-32-50	50	6	35	40	4
TR-32-63	63-80	7	40	45	5
TR-32-100	100	7	50	55	5

Supplied with:
1x centring ring

Centring pin Mod. TS-32-20

Designed both for the centring of the rear end caps with brackets L-32-20 / L-32-25 as for the centring of the cylinder while mounting.

Note: also suitable to use in holes "a" of the rear and front end caps of cylinders $\varnothing 20$ - $\varnothing 25$ or in the central hole of the rear end caps of cylinders $\varnothing 32$ - $\varnothing 40$.

Material: anodized AL

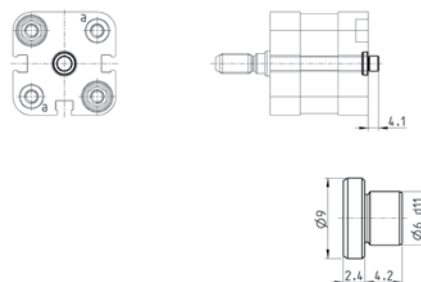

Mod.
TS-32-20

Supplied with:
1x centring pin

Self aligning rod Mod. GK

Only for cylinders with male rod.

Material: zinc-plated steel.

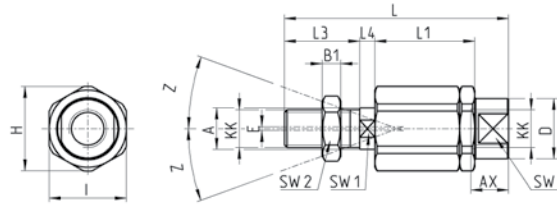
DIMENSIONS

Mod.	Ø	KK	L	L1	L3	L4	ØA	ØD	H	I	SW	SW1	SW2	B1	AX	Z	E
GK-20	20-25	M8x1,25	57	26	21	5	8	12,5	19	17	11	7	13	4	16	4	2
GK-25-32	32-40	M10x1,25	71,5	35	20	7,5	14	22	32	30	19	12	17	5	22	4	2
GK-40	50-63	M12x1,25	75,5	35	24	7,5	14	22	32	30	19	12	19	6	22	4	2
GK-50-63	80-100	M16x1,5	104	53	32	10	22	32	45	41	27	20	24	8	30	3	2

Coupling piece Mod. GKF

Material: zinc-plated steel.

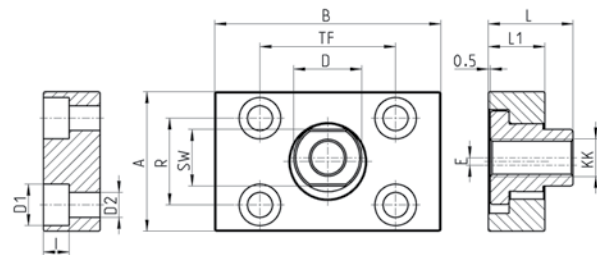
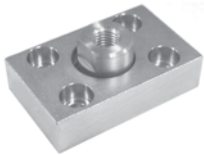
DIMENSIONS

Mod.	Ø	KK	A	B	R	TF	L	L1	I	ØD	ØD1	ØD2	SW	E
GKF-20	20-25	M8x1,25	30	35	20	25	22,5	10	-	14	5,5	-	13	1,5
GKF-25-32	32-40	M10x1,25	37	60	23	36	22,5	15	6,8	18	11	6,6	15	2
GKF-40	50-63	M12x1,25	56	60	38	42	22,5	15	9	20	15	9	15	2,5
GKF-50-63	80-100	M16x1,5	80	80	58	58	26,5	15	10,5	25	18	11	22	2,5