

Compact cylinders Series 31

Double and single-acting, double-acting non-rotating, magnetic
 ø12, 16, 20, 25
 ø 32, 40, 50, 63, 80, 100 UNITOP

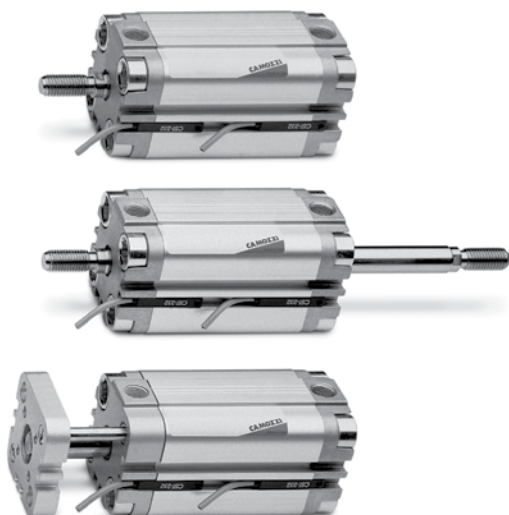

- » Compact design
- » Wide variety of models available
- » Standard magnetic
- » High temperature (double-acting and non magnetic)

The compact dimensions allow the cylinders to be installed within confined spaces. These cylinders are suitable for use with feet, flange and trunnion.

The compact single and double-acting cylinders Series 31 are available in 10 different bore sizes from ø 12 to ø 100. The guides are inserted in the external profile parallel to the sliding axis on three sides. These guides are used to locate the switches that sense the piston position. The construction design of these cylinders provides excellent axis stability. They are available either with a male or female thread. These cylinders can be supplied in W version for high temperatures (140°C). This version is not magnetic.

GENERAL DATA

Type of construction	compact profile
Operation	single and double-acting
Materials	body and end-blocks = AL - rod = rolled stainless steel AISI 303 - piston rod = AL - seals = PU or FKM for high temperatures (140°C)
Brackets	flange, feet, trunnion
Stroke min - max	Series 31R, 31M and 31F: ø12+25 = 1+200mm, ø32 + 63 = 1+300 mm, ø80+100 = 1+400mm The min. stroke for the use of sensors is 10 mm.
Operating temperature	0°C + 80°C (with dry air - 20°C)
Operating pressure	1 + 10 bar (double-acting); 2 + 10 bar (single-acting)
Fluid	filtered air, without lubrication. If lubricated air is used, it is recommended to use oil ISOVG32. Once applied the lubrication should never be interrupted.
Speed	10 ÷ 1000 mm/sec (without load)

STANDARD STROKE FOR COMPACT MAGNETIC CYLINDERS SERIES 31

● = Single-acting female, male ■ = Double-acting female, male ✕ = Non-rotating

STANDARD STROKES										
∅	5	10	15	20	25	30	40	50	60	80
12	■ ✕ ●	■ ✕ ●	■ ✕	■ ✕	■ ✕	■ ✕	■ ✕			
16	■ ✕ ●	■ ✕ ●	■ ✕ ●	■ ✕ ●	■ ✕ ●	■ ✕	■ ✕			
20	■ ✕ ●	■ ✕ ●	■ ✕ ●	■ ✕ ●	■ ✕ ●	■ ✕	■ ✕	■ ✕		
25	■ ✕ ●	■ ✕ ●	■ ✕ ●	■ ✕ ●	■ ✕ ●	■ ✕	■ ✕	■ ✕		
32	■ ✕ ●	■ ✕ ●	■ ✕ ●	■ ✕ ●	■ ✕ ●	■ ✕	■ ✕	■ ✕		
40	■ ✕ ●	■ ✕ ●	■ ✕ ●	■ ✕ ●	■ ✕ ●	■ ✕	■ ✕	■ ✕	■ ✕	■ ✕
50		■ ✕ ●	■ ✕ ●	■ ✕ ●	■ ✕ ●	■ ✕	■ ✕	■ ✕	■ ✕	■ ✕
63		■ ✕ ●	■ ✕ ●	■ ✕ ●	■ ✕ ●	■ ✕	■ ✕	■ ✕	■ ✕	■ ✕
80		■ ✕ ●	■ ✕ ●	■ ✕ ●	■ ✕ ●	■ ✕	■ ✕	■ ✕	■ ✕	■ ✕
100		■ ✕ ●	■ ✕ ●	■ ✕ ●	■ ✕ ●	■ ✕	■ ✕	■ ✕	■ ✕	■ ✕

CODING EXAMPLE

31	M	2	A	032	A	050
31	SERIES 31 = compact magnetic				PNEUMATIC SYMBOLS CS06 CD08 CD12 CS08	
M	VERSION M = male rod thread F = female rod thread R = non-rotating with flange only double-acting					
2	OPERATION 1 = single-acting, front spring 2 = double-acting 3 = double-acting, through-rod 4 = single-acting, rear spring					
A	MATERIALS A = rolled stainless steel AISI 303 rod - AL tube profile					
032	BORE 012 = 12 mm 016 = 16 mm 020 = 20 mm 025 = 25 mm 032 = 32 mm 040 = 40 mm 050 = 50 mm 063 = 63 mm 080 = 80 mm 100 = 100 mm					
A	DESIGN TYPE A = standard					
050	STROKE (see the table) = standard S = special V = rod seal FKM W = seals in FKM for high temperatures (140°C) double-acting, non magnetic					

PNEUMATIC SYMBOLS

The pneumatic symbols which have been indicated in the CODING EXAMPLE are shown below.

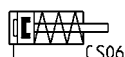
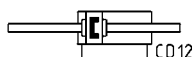
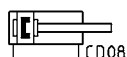

COMPACT MAGNETIC CYLINDERS SERIES 31



Swivel ball joint Mod. GA for cyl. 31M



90° swivel combination for trunnion Mod. I



Rear trunnion Mod. C



Rod fork end Mod. G for cyl. 31M



Piston rod lock nut Mod. U for cyl. 31M

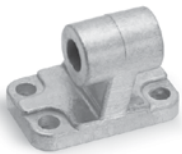

90° swivel combin. for fem. trunnion Mod. ZC



Rear trunnion Mod. L



Rear and front flange Mod. D



Foot mount Mod. B



Coupling piece Mod. GKF



Self aligning rod Mod. GK



Piston rod socket joint Mod. GY for cyl. 31M



All accessories are supplied separately.

ANTI-ROTATION - Transversal load dependant on stroke

1

MOVEMENT

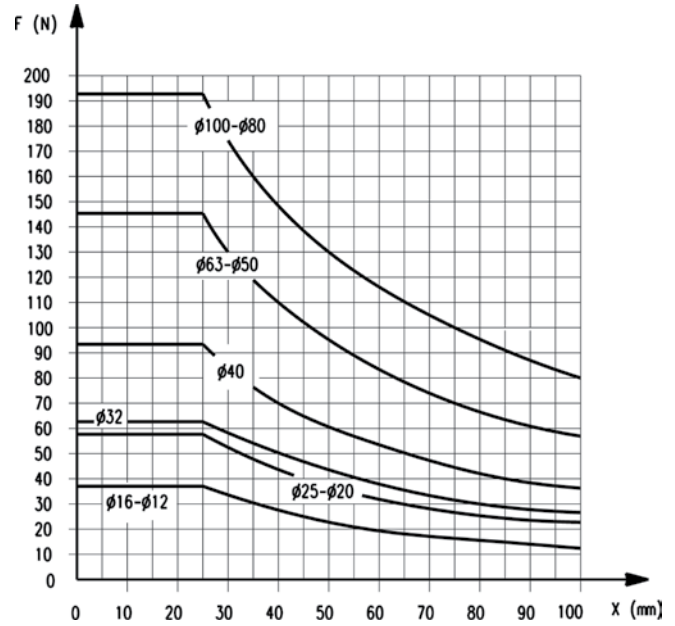
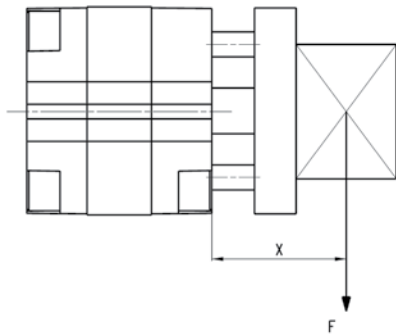

It is possible to determine the amount of strokes required in the general data (excluding radial loads and torque moments). When imposing radial loads on the cylinder it is important to respect the maximum stroke of the baricenter. In the presence of torque moments, respect the maximum stroke as shown in the diagrams.

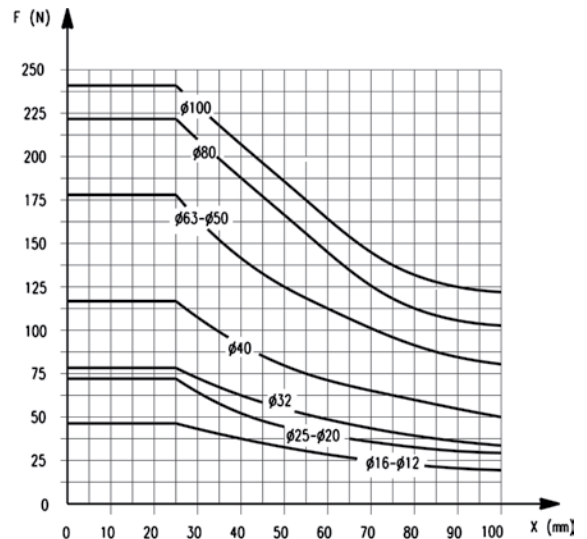
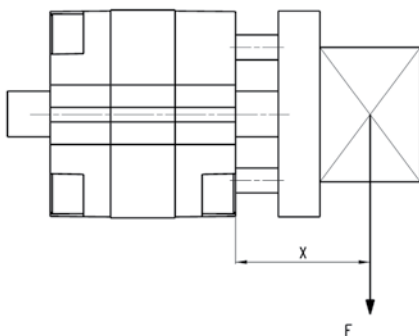
ANTI-ROTATION THROUGH-ROD - Transversal load dependant on stroke

It is possible to determine the amount of strokes required in the general data (excluding radial loads and torque moments). When imposing radial loads on the cylinder it is important to respect the maximum stroke of the baricenter. In the presence of torque moments, respect the maximum stroke as shown in the diagrams.

TORQUE MOMENT - dependant on stroke C

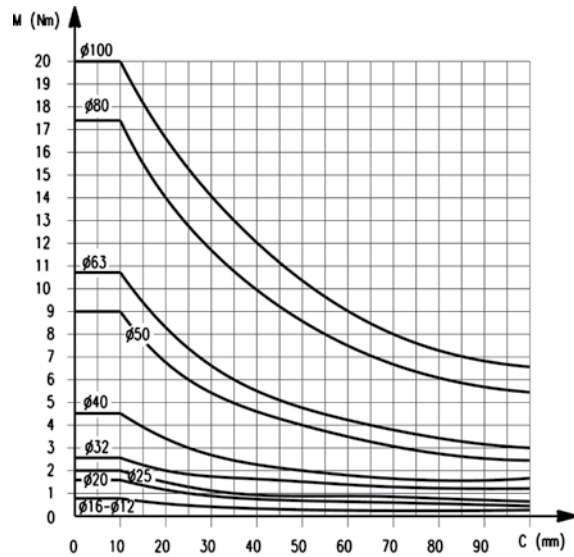
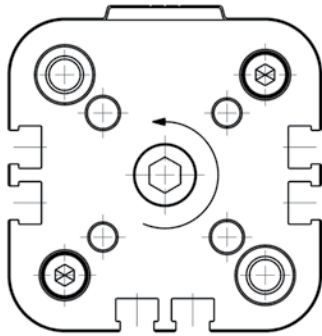

It is possible to determine the amount of strokes required in the general data (excluding radial loads and torque moments). When imposing radial loads on the cylinder it is important to respect the maximum stroke of the baricenter. In the presence of torque moments, respect the maximum stroke as shown in the diagrams.

TRANSVERSAL LOAD - dependant on stroke

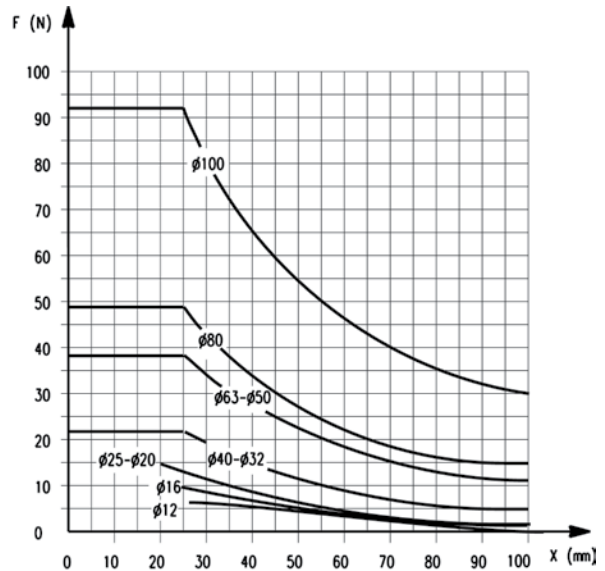
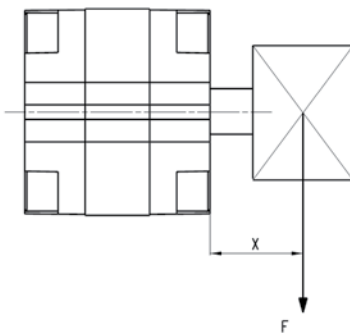

It is possible to determine the amount of strokes required in the general data (excluding radial loads and torque moments). When imposing radial loads on the cylinder it is important to respect the maximum stroke of the baricenter. In the presence of torque moments, respect the maximum stroke as shown in the diagrams.

TRANSVERSAL LOAD THROUGH-ROD - dependant on stroke

1

MOVEMENT

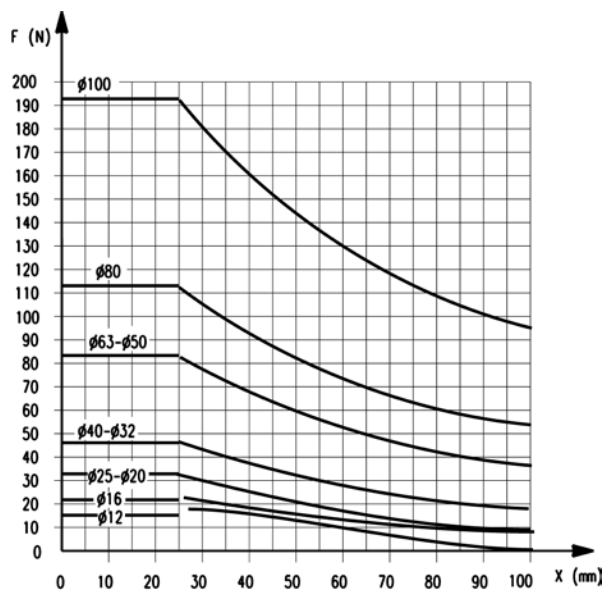
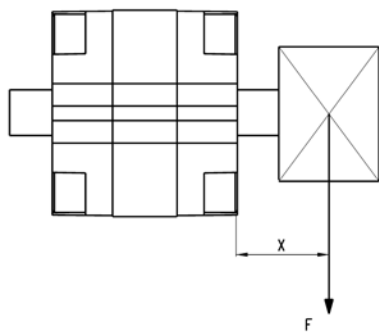

It is possible to determine the amount of strokes required in the general data (excluding radial loads and torque moments). When imposing radial loads on the cylinder it is important to respect the maximum stroke of the baricenter. In the presence of torque moments, respect the maximum stroke as shown in the diagrams.

Compact magnetic cylinders Mod. 31F and 31M



1 = Groove for sensor CST
 2 = Keep to the minimum screwing depth.
 + = add the stroke

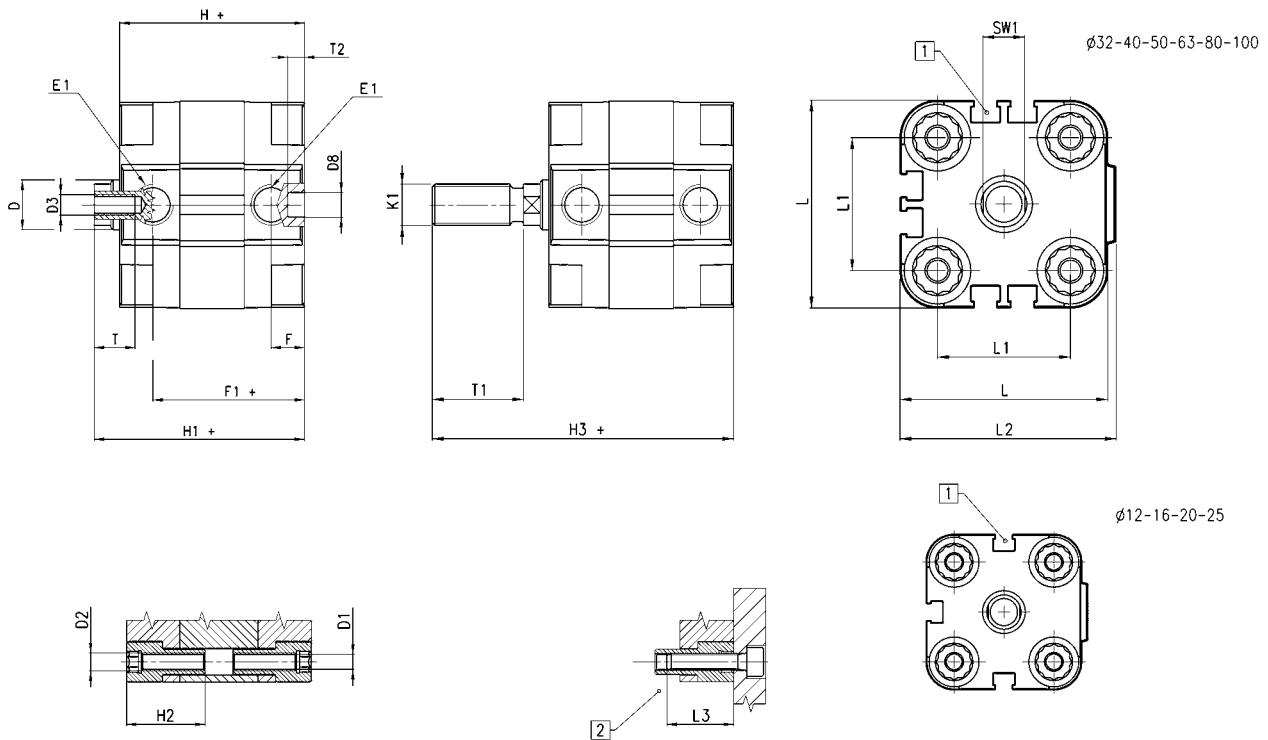

DIMENSIONS																					
∅	∅D	∅D1	D2	D3	∅D8 ^(H9)	E1	F	F1+	H+	H1+	H2	H3+	K1	L	L1	L2	L3	T	T1	T2	SW1
12	6	3,5	M4	M3	6	M5	8	30	38	42,5	18,5	58,5	M6	29	18	30	16	6	16	4	5
16	8	3,5	M4	M4	6	M5	8	30	38	42,5	18,5	62,5	M8	29	18	30	16	8	20	4	7
20	10	4,5	M5	M5	6	M5	8	30	38	42,5	18,5	64,5	M10x1,25	36	22	37,5	18	10	22	4	8
25	10	4,5	M5	M5	6	M5	8	31,5	39,5	45	18,5	67	M10x1,25	40	26	41,5	18	10	22	4	8
32	12	5,5	M6	M6	6	G118	8	36,5	44,5	50,5	21,5	72,5	M10x1,25	50	32	52	20	12	22	4	10
40	12	5,5	M6	M6	6	G118	8	37,5	45,5	52	21,5	74	M10x1,25	60	42	62,5	20	12	22	4	10
50	16	6,5	M8	M8	6	G118	8	37,5	45,5	53	22,5	77	M12x1,25	68	50	71	20	12	24	4	13
63	16	8,5	M10	M8	8	G118	8	42	50	57,5	24,5	81,5	M12x1,25	87	62	91	25	12	24	4	13
80	20	8,5	M10	M10	8	G118	8,5	47,5	56	64	24,5	96	M16x1,5	107	82	111	25	16	32	4	17
100	25	8,5	M10	M12	8	G114	10,5	56	66,5	76,5	31,5	116,5	M20x1,5	128	103	133	25	20	40	4	22

The company reserves the right to vary models and dimensions without notice.
 Products designed for industrial applications. Sale to general public is forbidden.

Compact magnetic cylinders Mod. 31F and 31M - through-rod



1 = Groove for sensor CST
 2 = Keep to the minimum screwing depth.
 + = add the stroke
 ++ = add the stroke 2 times

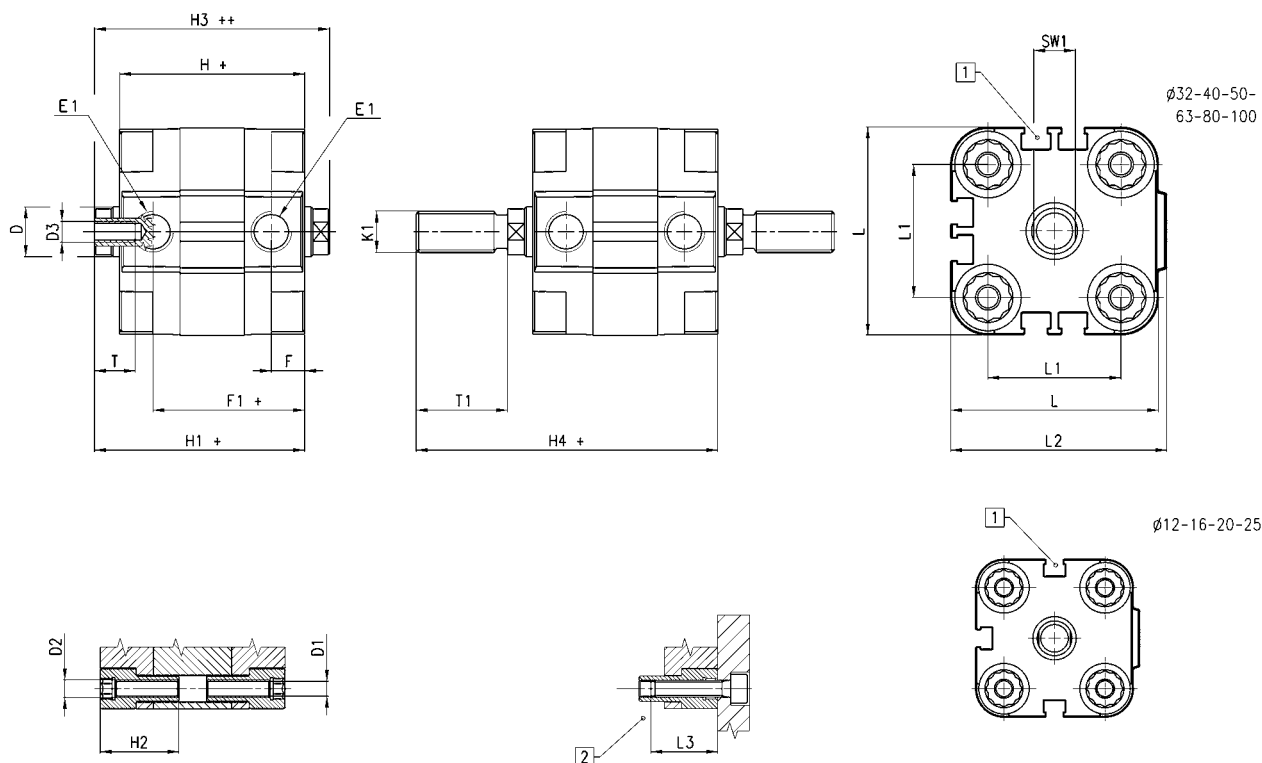

DIMENSIONS

∅	∅D	∅D1	D2	D3	E1	F	F1+	H+	H1+	H2	H3++	H4+	K1	L	L1	L2	L3	T	T1	SW1
12	6	3,5	M4	M3	M5	8	30	38	42,5	18,5	47	58,5	M6	29	18	30	16	6	16	5
16	8	3,5	M4	M4	M5	8	30	38	42,5	18,5	47	62,5	M8	29	18	30	16	8	20	7
20	10	4,5	M5	M5	M5	8	30	38	42,5	18,5	47	64,5	M10x1,25	36	22	37,5	18	10	22	8
25	10	4,5	M5	M5	M5	8	31,5	39,5	45	18,5	50,5	67	M10x1,25	40	26	41,5	18	10	22	8
32	12	5,5	M6	M6	G1/8	8	36,5	44,5	50,5	21,5	56,5	72,5	M10x1,25	50	32	52	20	12	22	10
40	12	5,5	M6	M6	G1/8	8	37,5	45,5	52	21,5	58,5	74	M10x1,25	60	42	62,5	20	12	22	10
50	16	6,5	M8	M8	G1/8	8	37,5	45,5	53	22,5	60,5	77	M12x1,25	68	50	71	20	12	24	13
63	16	8,5	M10	M8	G1/8	8	42	50	57,5	24,5	65	81,5	M12x1,25	87	62	91	25	12	24	13
80	20	8,5	M10	M10	G1/8	8,5	47,5	56	64	24,5	72	96	M16x1,5	107	82	111	25	16	32	17
100	25	8,5	M10	M12	G1/4	10,5	56	66,5	76,5	31,5	86,5	116,5	M20x1,5	128	103	133	25	20	40	22

Compact magnetic cylinders Mod. 31R



- 1 = Groove for sensor CST
- 2 = Keep to the minimum screwing depth.
- + = add the stroke
- ++ = add the stroke 2 times

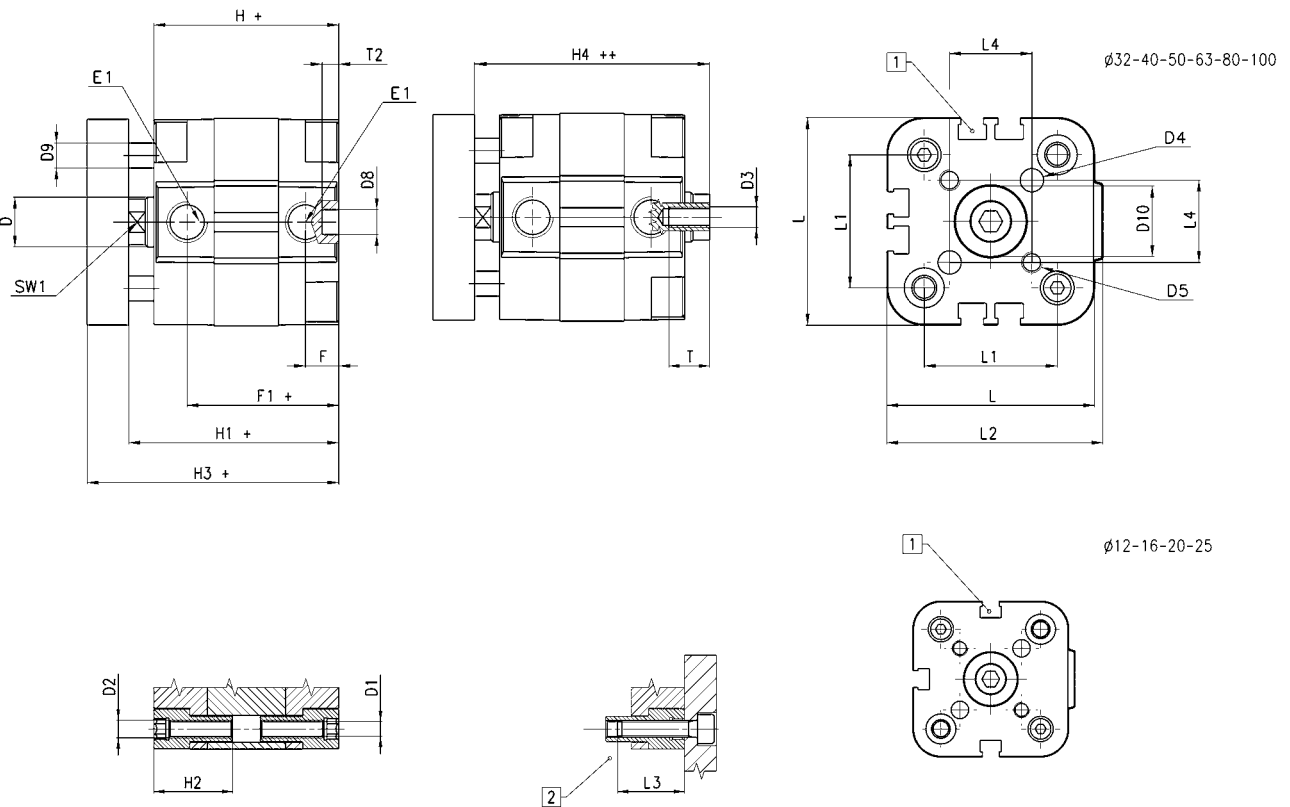

DIMENSIONS

∅	∅D	∅D1	D2	D3	∅D4 ^(H9)	D5	D8 ^(H9)	∅D9	D10	E1	F	F1+	H+	H1+	H2	H3+	H4++	L	L1	L2	L3	L4	T	T2	SW1
12	6	3,5	M4	M3	3	M3	6	5	6	M5	8	30	38	42,5	18,5	48,5	47	29	18	30	16	9,9	6	4	5
16	8	3,5	M4	M4	3	M3	6	5	8	M5	8	30	38	42,5	18,5	48,5	47	29	18	30	16	9,9	8	4	7
20	10	4,5	M5	M5	4	M4	6	6	10	M5	8	30	38	42,5	18,5	50,5	47	36	22	37,5	18	12	10	4	8
25	10	4,5	M5	M5	5	M5	6	6	14	M5	8	31,5	39,5	45	18,5	53	50,5	40	26	41,5	18	15,6	10	4	8
32	12	5,5	M6	M6	5	M5	6	6	17	G1/8	8	36,5	44,5	50,5	21,5	60,5	56,5	50	32	52	20	19,8	12	4	10
40	12	5,5	M6	M6	5	M5	6	6	17	G1/8	8	37,5	45,5	52	21,5	62	58,5	60	42	62,5	20	23,3	12	4	10
50	16	6,5	M8	M8	6	M6	6	10	22	G1/8	8	37,5	45,5	53	22,5	65	60,5	68	50	71	20	29,7	12	4	13
63	16	8,5	M10	M8	6	M6	8	10	22	G1/8	8	42	50	57,5	24,5	69,5	65	87	62	91	25	35,4	12	4	13
80	20	8,5	M10	M10	8	M8	8	12	28	G1/8	8,5	47,5	56	64	24,5	78	72	107	82	111	25	46	16	4	17
100	25	8,5	M10	M12	10	M10	8	12	30	G1/4	10,5	56	66,5	76,5	31,5	90,5	86,5	128	103	133	25	56,6	20	4	22

The company reserves the right to vary models and dimensions without notice.
Products designed for industrial applications. Sale to general public is forbidden.

Foot mount Mod. B

Material: zinc-plated steel

 Supplied with:
 2x feet
 4x screws

+ = add the stroke

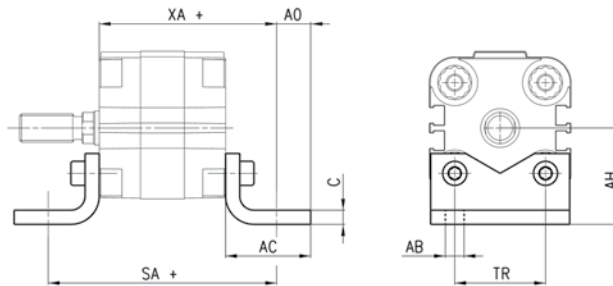
DIMENSIONS

Mod.	∅	C	SA+	XA+	TR	∅AB	AH	AO	AC
B-31-12-16	12 - 16	3	64	51	18	5,5	22	7	20
B-32-20	20	4	70	54	22	6,6	27	9	25
B-31-25	25	4	71,5	55,5	26	6,6	29	9	25
B-31-32	32	5	80,5	62,5	32	6,6	34	12	30
B-31-40	40	5	85,5	65,5	42	9	40,5	10	30
B-31-50	50	5,5	93,5	69,5	50	9	47	11	35
B-31-63	63	5,5	104	77	62	11	56,5	13	40
B-31-80	80	7,5	116	86	82	11	68,5	15	45
B-31-100	100	7,5	132,5	99,5	103	13,5	81	12	45

Rear and front flange Mod. D-E

Material: zinc-plated steel

 Supplied with:
 1x flange
 4x screws

+ = add the stroke

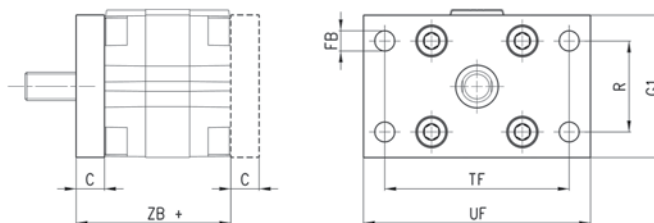
DIMENSIONS

Mod.	∅	C	ZB+	TF	R	UF	G1	∅FB
D-E-31-12-16	12 - 16	10	48	43	-	55	29	5,5
D-E-32-20	20	10	48	55	-	70	36	6,6
D-E-32-25	25	10	49,5	60	-	76	40	6,6
D-E-31-32	32	10	54,5	65	32	80	50	7
D-E-31-40	40	10	55,5	82	36	102	60	9
D-E-31-50	50	12	57,5	90	45	110	68	9
D-E-31-63	63	15	65	110	50	130	87	9
D-E-31-80	80	15	71	135	63	160	107	12
D-E-31-100	100	15	81,5	163	75	190	128	14

Female rear trunnion Mod. C

Material: Aluminium



Supplied with:
4x screws
1x clevis pin
1x centering pin
1x trunnion
+ = add the stroke

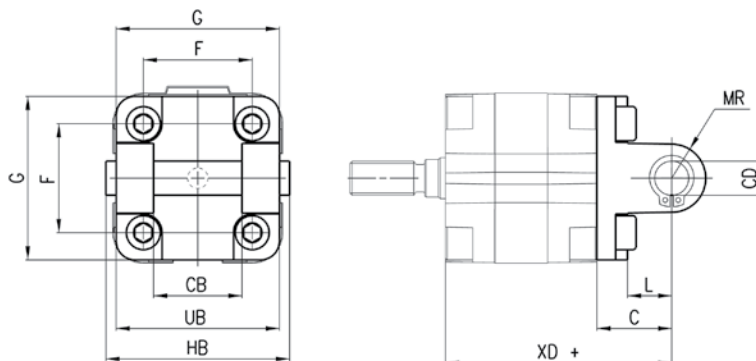

DIMENSIONS											
Mod.	∅	CD	L	C	XD+	MR	F	G	CB	UB	HB
C-31-32	32	10	13	21	66,5	11	32	50	26	45	54
C-31-40	40	12	16	25	70,5	13	42	60	28	52	62
C-31-50	50	12	16	27	72,5	13	50	68	32	60	70
C-31-63	63	16	21	32	82	17	62	87	40	70	82
C-31-80	80	16	23	36	92	17	82	102	50	90	102
C-31-100	100	20	26	41	107,5	21	103	128	60	110	126

Intermediate bracket Mod. DC

Flange in aluminium



Supplied with:
1x flange
1x centering pin
4x screws
+ = add the stroke

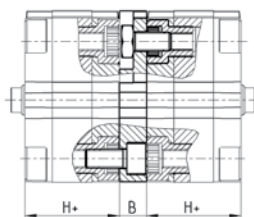

DIMENSIONS				
Mod.	∅	B	H+	
DC-31-12-16	12-16	12,5	38	400
DC-31-20	20	12,5	38	400
DC-31-25	25	13	39,5	400
DC-31-32	32	14,5	44,5	600
DC-31-40	40	14,5	45,5	600
DC-31-50	50	14,5	45,5	600
DC-31-63	63	14,5	50	600
DC-31-80	80	16,5	56	800
DC-31-100	100	19,5	66,5	800

90° Swivel combination for female trunnion Mod. ZC

 Male rear
 Material: aluminium

 Supplied with:
 1x male support

+ = add the stroke

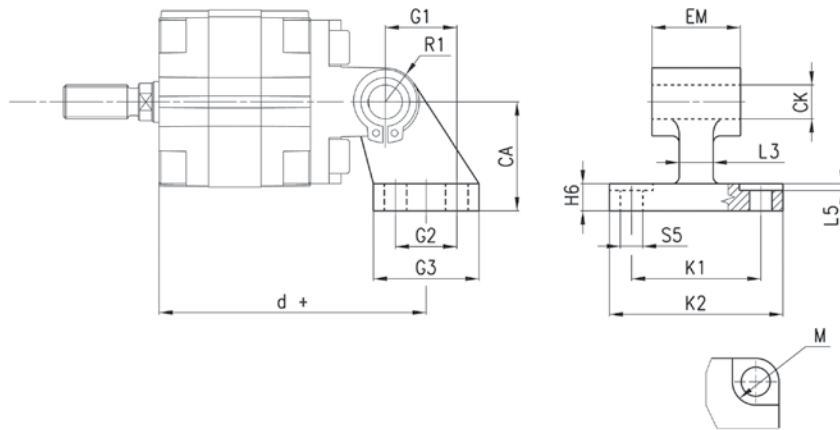
DIMENSIONS

Mod.	∅	M	∅CK	∅S5	d+	K1	K2	L3	G1	L5	G2	EM	G3	CA	H6	R1
ZC-32	32	11	10	6,6	78,5	38	51	10	21	1,6	18	26	31	32	8	10
ZC-40	40	11	12	6,6	83,5	41	54	15	24	1,6	22	28	35	36	10	11
ZC-50	50	15	12	9	90,5	50	65	16	33	1,6	30	32	45	45	12	13
ZC-63	63	15	16	9	101,5	52	67	16	37	1,6	35	40	50	50	14	15
ZC-80	80	18	16	11	119	66	86	20	47	2,5	40	50	60	63	14	15
ZC-100	100	18	20	11	137,5	76	96	20	55	3,2	50	60	70	71	17	19

90° swivel combination for trunnion Mod. I

Material: zinc-plated steel

 Supplied with:
 2x Seeger
 1x female support
 1x piston pin

+ = add the stroke

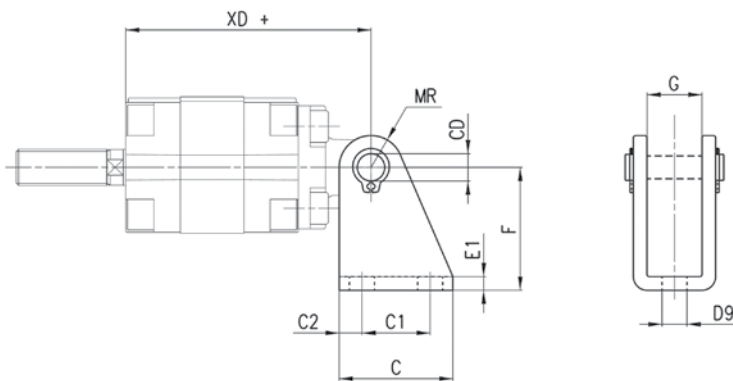

DIMENSIONS

Mod.	∅	∅CD	C	C1	∅C2	XD+	MR	∅D9	E1	F	G
I-12-16	12	6	25	15	5	54	7	5,5	3	27	12,1
I-12-16	16	6	25	15	5	54	7	5,5	3	27	12,1
I-20-25	20	8	32	20	6	58	10	6	4	30	16,1
I-20-25	25	8	32	20	6	59,5	10	6	4	30	16,1

Rear trunnion Mod. L

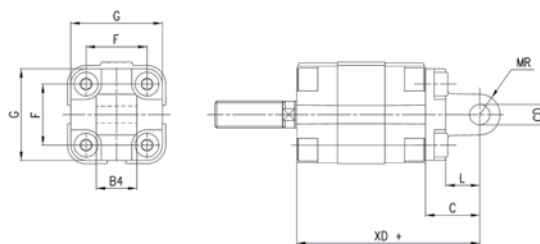

Male rear.
Material: aluminium
Supplied with:
4x screws
1x male trunnion
1x centering pin



DIMENSIONS									
	Ø	øCD	L	C	XD+	MR	F	G	B4
L-31-12-16	12	6	10	16	54	6	18	30	12
L-31-12-16	16	6	10	16	54	6	18	30	12
L-31-20	20	8	14	20	58	8	22	37,5	16
L-31-25	25	8	14	20	59,5	8	26	41,5	16

+ = add the stroke

Piston rod lock nut Mod. U



Material: zinc-plated steel
UNI EN ISO 4035

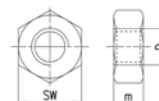

DIMENSIONS				
Mod.	Ø cylinder	D	m	SW
U-12-16	12	M6X1	4	10
U-20	16	M8X1,25	5	13
U-25-32	20-40	M10X1,25	6	17
U-40	50-63	M12X1,25	7	19
U-50-63	80	M16X1,5	8	24
U-80-100	100	M20X1,5	9	30

Swivel ball joint Mod. GA



Material: zinc-plated steel
ISO 8139

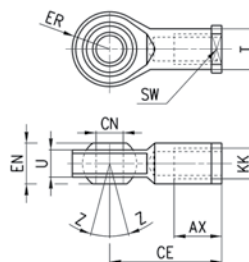

DIMENSIONS											
Mod.	Ø	øCN	U	EN	ER	AX	CE	KK	T	Z	SW
GA-12-16	12	6	7	9	10	12	30	M6X1	10	6,5	11
GA-20	16	8	9	12	20	16	36	M8X1,25	12,5	6,5	14
GA-32	20+40	10	10,5	14	14	20	43	M10X1,25	15	6,5	17
GA-40	50+63	12	12	16	16	22	50	M12X1,25	17,5	6,5	19
GA-50-63	80	16	15	21	21	28	64	M16X1,5	22	7,5	22
GA-80-100	100	20	18	25	25	33	77	M20X1,5	27,5	7	30

Rod fork end Mod. G

ISO 8140

Material: zinc-plated steel

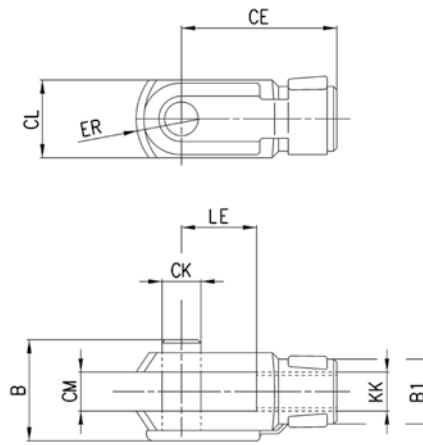
DIMENSIONS

Mod.	∅	B	∅B1	∅CK	LE	CM	CL	ER	CE	KK
G-12-16	12	16	10	6	12	6	12	7	24	M6X1
G-20	16	22	14	8	16	8	8	42	32	M8X1,25
G-25-32	20 + 40	26	18	10	20	10	20	12	40	M10X1,25
G-40	50 + 63	32	20	12	24	12	24	14	48	M12X1,25
G-50-63	80	40	26	16	32	16	32	19	64	M16X1,5
G-80-100	100	48	34	20	40	20	40	25	80	M20X1,5

Piston rod socket joint Mod. GY

Material: zama and zinc-plated steel

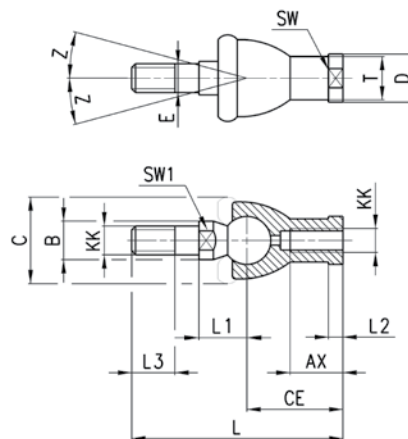
DIMENSIONS

Mod.	∅	S	L	CE	L2	AX	E	∅B	∅C	∅T	∅D	L1	L3	SW1	SW	Z
GY-12-16	12	M6X1	55	28	5	15	6	10	20	10	13	12,2	11	8	11	15
GY-20	16	M8X1,25	65	32	5	16	8	12	24	12,5	16	16	12	10	14	15
GY-32	20+40	M10X1,25	74	35	6,5	18	10	14	28	15	19	19,5	15	11	17	15
GY-40	50+63	M12X1,25	84	40	6,5	20	12	19	32	17,5	22	21	17	17	19	15
GY-50-63	80	M16X1,5	112	50	8	27	16	22	40	22	27	27,5	23	19	22	11
GY-80-100	100	M20X1,5	133	63	10	38	20	27	45	27,5	34	31,5	25	24	30	7,5

Self aligning rod Mod. GK

Material: zinc-plated steel

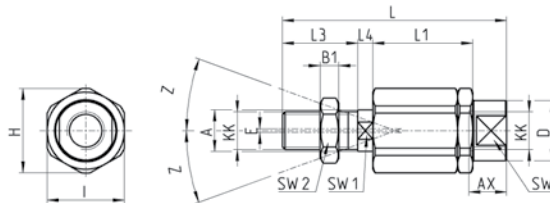

DIMENSIONS

Mod.	∅	KK	L	L1	L3	L4	∅ A	∅ D	H	I	SW	SW1	SW2	B1	AX	Z	E
GK-20	16	M8x1,25	57	26	21	5	8	12,5	19	17	11	7	13	4	16	4	2
GK-25-32	20-25-32-40	M10x1,25	71,5	35	20	7,5	14	22	32	30	19	12	17	5	22	4	2
GK-40	50-63	M12x1,25	75,5	35	24	7,5	14	22	32	30	19	12	19	6	22	4	2
GK-50-63	80	M16x1,5	104	53	32	10	22	32	45	41	27	20	24	8	30	3	2
GK-80-100	100	M20x1,5	119	53	40	10	22	32	45	41	27	20	30	10	37	3	2

Coupling piece Mod. GKF

Material: zinc-plated steel

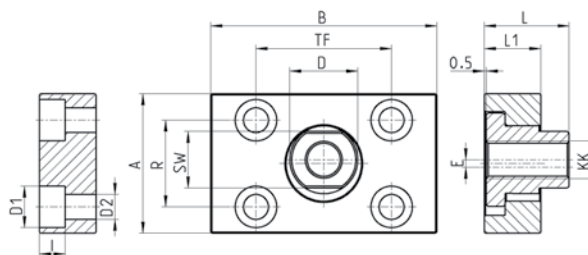
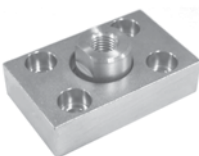

DIMENSIONS

Mod.	∅	KK	A	B	R	TF	L	L1	I	∅ D	∅ D1	∅ D2	SW	E
GKF-20	16	M8x1,25	30	35	20	25	22,5	10	-	14	5,5	-	13	1,5
GKF-25-32	20-25-32-40	M10x1,25	37	60	23	36	22,5	15	6,8	18	11	6,6	15	2
GKF-40	50-63	M12x1,25	56	60	38	42	22,5	15	9	20	15	9	15	2,5
GKF-50-63	80	M16x1,5	80	80	58	58	26,5	15	10,5	25	18	11	22	2,5
GKF-80-100	100	M20x1,5	90	90	65	65	32,5	20	13	30,5	20	14	27	2,5