



33

Netter Frequency and Voltage Converters Series FSW



- Robust and approved design
- Performance suitable to sites
- Long lifetime
- IP 54 isolation specification F
- Primary: 400 V, 50 Hz
- Secondary: optional 42 V, 200 Hz or 250 V, 200 Hz
- Two-wheel cart from FSW 7,5





NetterVibration



Netter Frequency and Voltage Converters Series FSW

Techn. Data	FSW 3	FSW 4	FSW 5,5	FSW 7,5	FSW 11	FSW 15	FSW 20	FSW 25	FSW 30	FSW 45
Primary	Voltage at 50/60 Hz [V]	400	400	400	400	400	400	400	400	400
	Current [A]	6,1	8,1	10,0	14,0	22,0	28,0	36,0	44,0	69,0
Secondary	Nominal current at 42 V, 200 Hz [A]	41,5	55,0	76,0	105	151,0	207,0	275,0	344,0	619,0
	Nominal current at 250V, 200 Hz [A]	7,00	9,25	12,70	17,50	24,00	32,70	43,50	54,50	69,60
	Nominal power [kVA]	3,0	4,0	5,5	7,5	11,0	15,0	20,0	25,0	30,0
Quantity of sockets	2	3	3	4**	terminal boxes					
Weight [kg]*	52	48	58	100	110	190	205	230	240	330

*Weight without protection frame or two-wheel cart **optional with terminal box

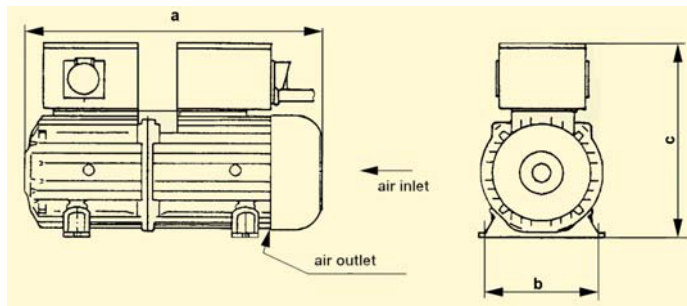

Suitable for:



Netter Electric Internal Vibrators

Netter Electric External Vibrators

Dimensions in mm	FSW 3	FSW 4	FSW 5,5	FSW 7,5	FSW 11	FSW 15	FSW 20	FSW 25	FSW 30	FSW 45
a	507	501	555	555	844	1058	1058	1058	1058	1252
b	196	251	251	251	256	310	310	310	310	340
c	342	420	420	420	360	416	416	416	416	463

Possible connections*	FSW 3	FSW 4	FSW 5,5	FSW 7,5	FSW 11	FSW 15	FSW 20	FSW 25	FSW 30	FSW 45
NCZ 300	5	6	9	12	18	-	-	-	-	-
NCZ 370	5	6	9	12	18	-	-	-	-	-
NCZ 480	3	3	5	6	10	-	-	-	-	-
NCZ 560	1	2	3	4	6	-	-	-	-	-
NCZ 560 L	1	2	3	4	7	-	-	-	-	-
NCZ 660	1	2	3	3	5	-	-	-	-	-
NCZ 800	-	1	2	2	4	-	-	-	-	-
NEG/NEH 756	4	6	8	11	16	23	30	38	45	68
NEG/NEH 1206	3	4	6	8	11	16	21	26	32	48
NEG/NEH 1606	3	4	5	7	10	14	19	24	29	44

* Designed for simultaneous operation of the indicated number of vibrators.

Applications

Netter series FSW frequency and voltage converters convert the local main voltage into protection voltage.

They are particularly suitable for the operation of Netter internal vibrators series NCZ, NCZ/S, NCX and NCX/S as well as external vibrators series NEG/NEH.

The frequency and voltage converters are available with 42 V or 250 V secondary voltage. FSW converters are equipped with the maximum possible number of CEE (32 A) power sockets.

The required power performance is determined by the internal vibrators to be connected.

A thermal motor protection switch shuts the unit off when current consumption levels are too high.

Safety

Personal safety is assured by means of galvanic isolation.

Permissible operating conditions

Connecting values:
FSW 2 to FSW 45: primary 400 V, 50 Hz, secondary 42 V, 200 Hz

Ambient temperature:

0°C to 40°C.

Netter provides solutions.

Consult our experienced application technicians.

Netter GmbH

Germany

Fritz-Ullmann-Str. 9
55252 Mainz-Kastel
Tel. +49 6134 2901-0

Poland

Al. W. Korfantego 195/17
40-153 Katowice
Tel. +48 32 2050947

Switzerland

Erlenweg 4
4310 Rheinfelden
Tel. +41 61 8316200

Spain

Errota Kalea 8
20150 Villabona-Guipúzcoa
Tel. +34 943 694 994

www.NetterVibration.com
info@NetterVibration.com