



WEIGHING INDICATOR

IPE 50

USER MANUAL

(valid from version 4.00)



SCAIME SAS
BP501
F 74105 ANNEMASSE

Tél : +33 4 50 87 78 64
Fax : +33 4 50 87 78 46
www.scaime.com

INDEX

| | |
|--|---------|
| 1 INTRODUCTION..... | page 2 |
| 2 MAIN TECHNICAL SPECIFICATIONS | page 3 |
| 3 DIMENSIONS | page 4 |
| 4 POWER SUPPLY & START-UP..... | page 5 |
| 5 FRONT PANEL KEYS AND INDICATORS | page 5 |
| 6 BASIC FUNCTIONS | page 7 |
| 7 SELECTABLE OPERATING MODES..... | page 11 |
| 8 INSTRUMENT MESSAGES WHILE IN USE | page 19 |
| 9 PRINTING EXAMPLES | page 20 |
| 10 INSTALLATION..... | page 21 |
| 11 BLOCK DIAGRAM | page 22 |
| 12 SET UP | page 25 |
| 13 ADJUSTMENT..... | page 35 |
| 14 SERIAL OUTPUTS..... | page 40 |
| 15 PROGRAMMING THE PRINTOUTS | page 48 |
| 16 ERROR MESSAGES..... | page 52 |
| 17 CONNECTION SCHEMES | page 52 |

1 INTRODUCTION

The purpose of this manual is to help the user get to know the weight indicator's various functioning modes, the keys' functions and the display indications

We advise to carefully follow the instructions for programming the weight indicator; by taking actions not indicated this manual, one could cause the scale to not work properly.

In addition to having all the characteristics of a high precision scale, the indicator has the kg/lb conversion function, the gross weight / net weight conversion, set point on gross weight or net weight, in/out weigh, repeater in r.f. transmission, alibi memory, hold function, peak detector, weighs totaliser and piece counter.

The indicator adapts to normal weighing applications in either industrial settings, such as during factory production processes, or that of commerce, such as legal for trade applications, also satisfying the frequently needed ability to transmit and print the data through its two bidirectional serial ports.

This manual has been made as carefully and exactly as possible; in any case, your suggestions are always welcome.



Any attempt to repair or alter the unit can expose the user to the danger of electric shock and it will void our warranty. This instrument is covered under warranty provided that **IT HAS NOT BEEN OPENED BY THE USER** for any reason. If any problem with the unit or system has been experienced please notify the manufacturer or the dealer from which the instrument was acquired.

Do not pour liquids on the indicator!

Do not use solvents to clean the indicator!

Do not expose instrument to either direct sun light or any heat sources!

Always mount the indicator and platform in a vibration free setting!

Read carefully & apply what described in the POWER SUPPLY & START-UP section!

Do not install in an environment with any risk of explosion!

2 MAIN TECHNICAL SPECIFICATIONS

| | |
|---------------------------|---|
| POWER SUPPLY | 12 to 24Vdc / 3.6 W max |
| OPERATING TEMPERATURE | From -10 to +40 °C (14 to 104 °F). |
| DISPLAYED DIVISIONS | 10000e, 2X3000e for legal for trade use expandable to 800.000 for internal use (with minimum signal coming from the 1,6mV/V cell). |
| RESOLUTION IN CALCULATION | 150'000 points (with signal in input equal to 3mV/V). |
| MAX INPUT | + 30mV (+ 6mV/V) |
| DISPLAY | 6 digits, 13 millimetres high |
| STATUS INDICATIONS | 6 LEDS |
| KEYBOARD | water resistant polycarbonate membrane keys with tactile and acoustic feedback. |
| TARE FUNCTION | Available on entire range, from keyboard or from optional remote control. Subtraction function on all models. |
| LOAD CELL POWER SUPPLY | 5Vdc \pm 5%, 120mA (max 8 cells of 350 Ohm) |
| LOAD CELL CONNECTIONS | 4 or 6 wires with Remote Sense (4 or 6 wires on channel 1 and 4 wires on channel 2 to 4) |
| PROTECTIVE CASE | IP 54 , PVC case |
| SERIAL OUTPUTS | 1 RS232 uni directionnal configurable for connection to a printer or repeater. 1 RS485 bi directionnal for connection to PC/PLC or repeater. |

THE PARTS OF THE INSTRUMENT CONTAINING DANGEROUS ELECTRICAL TENSION ARE ISOLATED AND INACCESSIBLE TO THE USER UNLESS IT HAS BEEN DAMAGED, OPENED, OR ALTERED.

3 DIMENSIONS

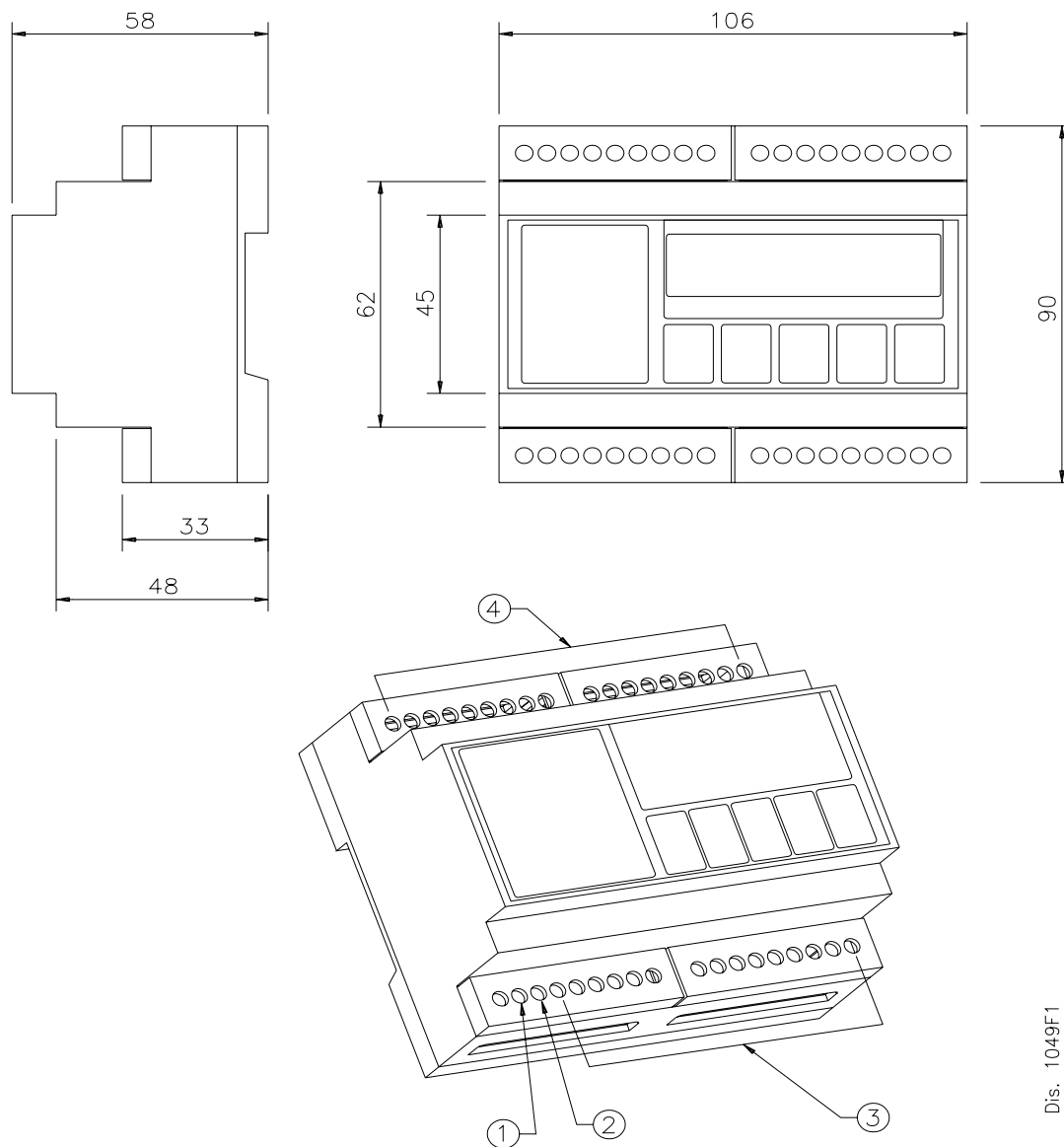

Dis. 1049F1

- 1 and 2 Connection of power supply (12 to 24Vdc)
- 3 connection of the 2 inputs, the contact of setpoints and RS232 and 485
- 4 connection of 1 to 4 sensors

4 POWER SUPPLY & START UP

Do not connect other equipment to the same socket as the one that the adapter is in.
Do not step on or crush the power supply cable

The display shows in sequence:

L.X.YY

09.01 09 indicate the type of unit, 01 indicate the version of metrologic software

XX.YY.ZZ version of the installed software.

DGT name of software

CloCK if the option timer is installed.

After this, the programmed capacity and minimum division are displayed; then the instrument executes a countdown (self-check) and finally "hi rES" is displayed (in case of non approved instrument) or "LEGAL" and the calibration area (in case of approved instrument).

The indicator has an "auto zero at start-up" function: in other words it means that, with a non approved instrument the display shows the present weight after a few instants, while with an approved instrument "ZerO" is shown continuously on the display, until the weight does not re-enter within this tolerance; the auto zero function at start-up may be disabled in the set-up environment (only with non approved instrument); see **SEtuP >> ConFiG >> Param. >> Auto-0 (TECH.MAN.REF.)**

TO stand by the IPE50, keep the C key pressed until the - OFF – message appears on the display; then release the key (the power supply of the sensors 5V is always present).

Press the C key to restart the unit.



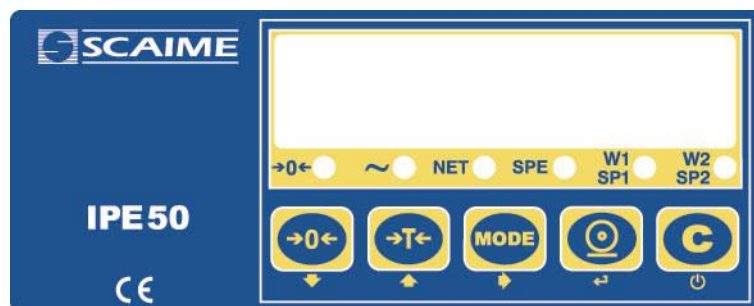

To TURN OFF the IPE50, switch off the power supply

5 IPE50 FRONT PANEL KEYS AND INDICATORS

The front panel of the indicator is designed for quick but simple weighing applications. It consists of an LCD display with 6 digits 13 mm in height, 6 LED indicators and a keyboard 5 function keys.



| VOYANTS | FONCTIONS |
|------------------------|--|
| ->0<- | Indicates that the weight detected on the weighing system is near zero, within the interval of $-1/4$ to $+1/4$ of the division. |
| ~ | Indicates that the weight is unstable. |
| NET | Indicates that the displayed weight is a net weight. |
| SPE | Indique que l'IPE50 est dans un mode de fonctionnement particulier |
| W1/ SP1 ou W2 / SP2 | W1 or W2 show the fonctionnement with 2 weighing ranges SP1 or SP2 Indicates that the relay 1 or 2 has been enabled. |

| SCALE KEY | FUNCTION |
|---|---|
|  | <ul style="list-style-type: none"> - Zeros the displayed gross weight, if is within +/- 2% of the total capacity. - Cancels the negative tare value. |
|  | <ul style="list-style-type: none"> - If pressed for an instant it carries out the semiautomatic tare. - If pressed at length it allows entering the manual tare from keyboard. - Cancels the negative tare value. - In the numeric input phase it increases the digit to be modified. |
|  | <ul style="list-style-type: none"> - It carries out a specific function of the operating mode set in the set-up environment. - In the numeric input phase it selects the digit to be modified, from left to right. |
|  | <ul style="list-style-type: none"> - It carries out a specific function of the operating mode set in the set-up environment. - In the numeric input phase, it confirms the entry made. - In the SET-UP, it allows to enter a step or to confirm a parameter within a step. - It transmits the data from the serial port dedicated to the printer. |
|  | <ul style="list-style-type: none"> - It turns the instrument in the mode stand by. - In the numeric input phase, it quickly zeros the present value. - In the set-up environment, it allows to exit a step without confirming the change made. - cancel a tare |

6 BASIC FUNCTIONS

Nota : if the IPE50 has never calibrated, the message "Err 39" will be displayed (see page 51)

3 modes of functioning are available:

Ind.Ch. Standard using for 1 to 4 independant channels (selection of the channel displayed by the key "MODE" and key "->T<-" and validation with key "ENTER")

DEP.Ch. Using for the connection of 2 to 4 identical sensors on a same system

TrAnSM. same as for ind.Ch, except that the keys, the zero tracking and the autozero at the startup are disabled and it is possible with one serial command, to receive the values of all the activated channels .

6.1 ZERO SCALE

By pressing the ->0<- key, it is possible to zero a gross weight value which is within +/- 2% of the capacity; after the zeroing, the display shows 0 weight and the relative pilot lights are turned on.

6.2 TARE OPERATIONS

SEMI-AUTOMATIC TARE

By pressing the ->T<- key any weight value present on the display is tared: the display shows "tArE" for an instant and then 0 (net weight); the relative keys turn on.

In any case a new tare operation cancels and substitutes the previous one.

NOTE: The semiautomatic tare will be acquire only if the weight is AT LEAST A DIVISION, STABLE (instability ~ led off) and VALID (in other words, the OVERLOAD condition should not be created).

ENTERING THE MANUAL TARE FROM KEYBOARD

Press ->T<- for a few seconds: the display shows "- tM -" and then "000000". Enter the desired value using the following keys:

->0<- decreases the blinking digit.

->T<- increases the blinking digit.

MODE selects the digit to be modified (blinking); the scrolling of the digits takes place from left to right.

C if pressed for an instant it quickly zeros the present value; if pressed at length it allows to return to weighing without saving the changes made.

NOTE: With the IPE50 one enters the value directly with the numeric keyboard

Confirm with the ENTER key; the value will be subtracted from the weight present on the plate and the relative pilot lights will turn on.

If the entered value is not a multiple of the scale's minimum division, it will be rounded up if it is equal or greater than half of the division, or rounded down if lower.

In any case a new tare operation cancels and substitutes the preceding one.

CANCELLING A TARE

One can manually cancel the tare value in different ways:

- unload the scale and press the ->0<- ou ->T<- key.

- carry out the tares in deduction, partially unloading the scale and pressing ->T<- to zero the display.

- press C without unloading the scale.

- enter a manual tare equal to 0.

NOTE: it is possible to automatically cancel the tare value; see the section "LOCKED/UNLOCKED/DISABLED TARE SELECTION".

SELECTION OF LOCKED / UNLOCKED / DISABLED TARE

Normally, when a tare value is entered (automatic, manual, or from storage) by unloading the scale plate,

the display shows the tare value with a negative sign (LOCKED TARE). For one's convenience it is also possible to choose that the tare value cancels itself automatically each time that the scale is unloaded (UNLOCKED TARE); or disable the tare functions.

With the UNLOCKED tare:

In case of SEMIAUTOMATIC TARE the net weight, before unloading the scale, may also be 0.

In case of MANUAL TARE or FROM DATABASE the net weight before unloading the scale must be of at least 2 stable divisions.

To set the type of tare:

- Turn on the indicator, press the ->0<- or ->T<- key during the countdown (the display shows the "FmodE" menu).
- Press ENTER to enter the menu.
- Press ->0<- many times (to scroll ahead through the parameters) or ->T<- (to scroll backwards) until one finds the "tArE t" parameter.
- Press ENTER to enter the parameter.
- With the ->0<- or ->T<- keys select the possible options: "LoCK" (locked tare), "unLoCK" (unlocked tare), diSAb (disabled tare).
- Confirm with ENTER
- Press the C key many times until the display shows the message "SAVE?".

Press ENTER to confirm the changes made or another key for not saving.

The indicator stores the last selection made, also after it is turned off.

6.3 AUTO POWER OFF FUNCTION (OPTION)

It is possible to automatically turn off the indicator (from 1 to 255 minutes), or disable it; the auto power off takes place when, **with unloaded scale**, or a key has not been pressed for the time set: the display shows the "- oFF - " blinking message and the indicator turns off.

For the setting, follow the procedures below:

- Turn on the scale, press the ->0<- or ->T<- key during the countdown (the display shows the "FmodE" menu).
- Press ENTER to enter the menu.
- Press ->0<- many times (to scroll ahead through the parameters) or ->T<- (to scroll backwards) until one finds the "AutoFF" parameter.
- Press ENTER to enter the parameter.
- With the ->0<- or ->T<- keys select the possible options: "diSAb" (auto switch-off disabled), "EnAb" (auto switch-off enabled).
- Confirm with ENTER if "EnAb" has been selected, one will be asked to enter the number of minutes after which the indicator should turn off: enter a number between 1 and 255 (using the MODE key to select the digit to be modified and ZERO/TARE to decrease/increase it) and confirm with ENTER
- Press many times the C key until the display shows "SAVE?".

Press ENTER to confirm the changes made or another key for not saving.

6.4 MULTI RANGE FUNCTIONING (for legal for trade approved instruments)

The multi range functioning allows to subdivide the scale capacity in two ranges, each which is up to 3000 divisions, improving in this way the first range division in the dual range and the first two ranges in the triple range.

For example, with a 10 kg cell platform it is possible to approve the weighing system with:

- A single range: 6 kg capacity and 2 g division (3000 div.).
- Dual range: 6 / 3 kg capacity and 2/1 g division (3000 + 3000 div.).

NOTE: The selection of the range number with multirange functioning is made during the indicator's calibration

6.5 DATE/TIME ADJUSTMENT (OPTIONAL)

The indicator can be fitted with the date/time option; in this case, the "CLoCK" message is shown when instrument is turned on.

To set the date/time follow the procedure below:

- Turn on the scale, press the ->0<- or ->T<- key during the countdown (the display shows the "FmodE" menu).
- Press ENTER to enter the menu.
- Press ->0<- many times (to scroll forwards through the parameters) or ->T<- (to scroll backwards) to find the "CLoCK" parameter.
- Confirm with ENTER/PRINT: in this order one will be asked to enter the day, month, year, hour, and minutes. The entry of each parameter must be confirmed with ENTER
- Press the C key many times until the message "SAVE?" appears on the display.
- Press ENTER to confirm the changes made or another key to not save.
- It is possible to programme the date and time during the weighing, pressing in sequence the F and 8 keys.
- **The "CLoCK" parameter is not displayed if there is no date/time option.**

6.6 "SCREEN SAVER" FUNCTION (OPTIONAL)

If the indicator is fitted with the date/time function, it is possible to enable the "Screen Saver": after a programmable time (from 1 to 255 minutes) with the scale unloaded, the time is shown on the display, in the "HH-MM.SS" format. As soon as a weight variation is detected, or a key is pressed, the indicator returns to viewing the current weight.

To set the function:

- Turn on the scale, press the ->0<- or ->T<- key during the countdown (the display shows the "FmodE" menu).
- Press ENTER to enter the menu.
- Press ->0<- many times (to scroll forwards through the parameters) or ->T<- (to scroll backwards) to find the "SCr.SAV" parameter.
- Press ENTER to enter the parameter.
- With the ->0<- or ->T<- key select the possible options: "no" (disabled), "YES" (enabled).
- Confirm with ENTER if one has selected "YES", one is asked to enter the number of minutes after which the indicator should show the time: enter a number between 1 and 255 (using the MODE key to select the digit to be modified and the ZERO/TARE keys to decrease/increase it) and confirm with ENTER
- Press the C key many times until the display shows the message "SAVE?".
- Press ENTER to confirm the changes made or another key to not save.

NOTE: the "SCr.SAV" parameter is not shown if there is no date/time option.

6.7 PRINTING

If a printer is connected, it is possible to print the programmed weight data, for example:

- GROSS weight
- TARE weight
- NET weight
- ticket number
- date and time (optional)
- a CODE 39 bar code (both with the LP542PLUS labeller as well as the TP200 thermal printer).

Besides the generic printing described above, each single functioning mode will have some specific printouts, which are described in the operating mode.

Executing printouts with NON approved scales.

In order to print with non approved scales the following conditions must exist:

- the weight must be stable;
- the gross weight must be \geq of a division;

To configure the printouts, go to the "PROGRAMMING THE PRINTOUTS"

6.8 REENABLING THE PRINTOUTS AND THE INDICATOR FUNCTIONS

While using the indicator, it is possible to incur into the “no.0.unS” error shown on the display along with an acoustic signal; this means that the printing or the function which one wants to carry out must be reenabled (in order to avoid unwanted executions).

It is possible to set the reenabling in different ways: “passage by zero of the net weight”, “weigh instability” or “always”. Follow the procedure below:

- Turn on the scale, press the ->0<- or ->T<- key during the countdown (the display shows the “FmodE” menu).
- Press ENTER to enter the menu.
- Press ->0<- many times (to scroll forwards through the parameters) or ->T<- (to scroll backwards) until one finds the “rEAct” parameter.
- Press ENTER to enter the parameter.
- With the ->0<- or ->T<- keys select the possible options: “ZEro” (passage by zero of the net weight), “inSt” (instability), ALWays.
- Confirm with ENTER
- Press the C key many times until the message “SAVE?” is shown on the display.
- Press ENTER to confirm the changes made or another key to not save.

7 SELECTABLE OPERATING MODES

In addition to the STANDARD weighing mode with TARE deduction and transmission of data, the indicator can carry out one of the following functions:

kg/lb CONVERSION, NET/GROSS SWITCH, SET POINT ON THE GROSS WEIGHT, SET POINT ON THE NET WEIGHT, IN/OUT, ALIBI, DISPLAY WITH SENSITIVITY X 10, HOLD, PEAK, HORIZONTAL TOTALIZER, VERTICAL TOTALIZER, and PIECE COUNTING.

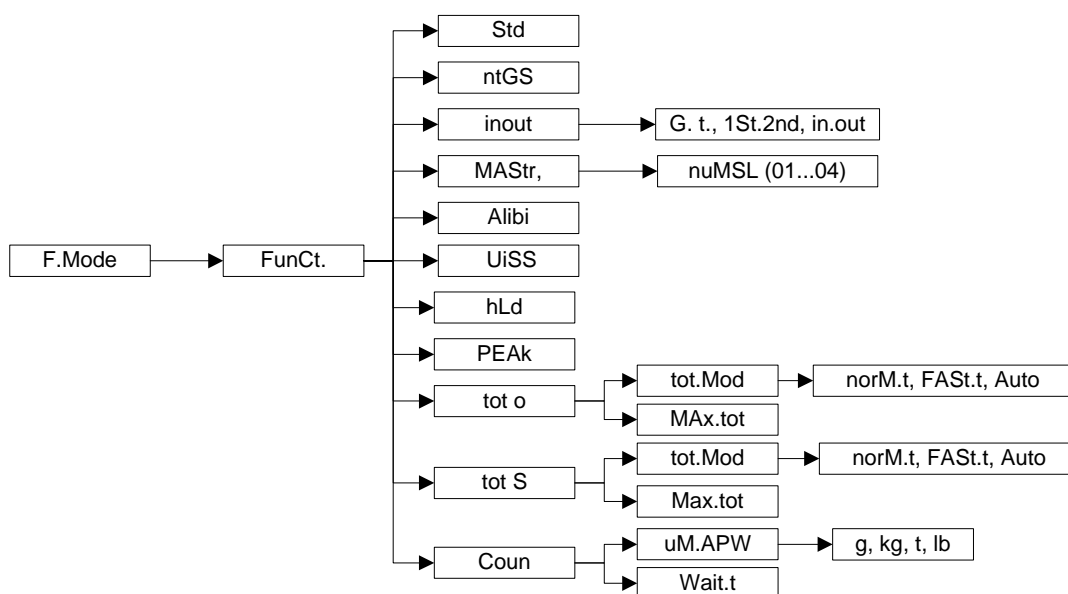

To set the operating mode, carry out the following procedures:

- Turn on the scale, press the ->0<- or ->T<- key during the countdown (the display shows the “FmodE” menu).
- Press ENTER to enter the menu (the display shows the “FunCt” menu).
- Press ENTER to enter the parameter.
- With the ->0<- or ->T<- keys select the possible options:

| | |
|--------------|--------------------------------------|
| Std | kg / lb conversion |
| ntGS | net weight / gross weight conversion |
| inout | Input / output weighing |

| | |
|--------------|---|
| MAStr | Master for using with 1 to 4 another IPE50 in slave |
| ALibi | Non available |
| UiSS | Sensitivity (x10) |
| hLd | Hold |
| PEAK | Peak detector |
| tot o | Horizontal totalizer |
| tot S | Vertical totalizer |
| Coun | Counting |

- Confirm with ENTER if one has selected the inout, tot or, tot S or Coun mode, one will be asked to select another operating parameter; refer to the specific functioning mode section for the relative description.
- Once the functioning mode is selected, one is asked to enable the standard printouts: the "dEF.Pr?" message appears on the display: press ENTER to enable the printouts and C to exit without making any modifications.
- The instrument automatically goes to the following step.
- Press many times the C key until the display shows the message "SAVE?".
- Press ENTER to confirm the changes made or another key to not save.

7.1 kg/lb CONVERSION (Std)

By pressing "MODE" key the value is converted from kg to lb and vice versa.

NOTES:

- with APPROVED instrument in single range the weight in pounds is displayed for 5 seconds, after which the display goes to kilograms. During the viewing in pounds it is not possible to print the weight (when pressing ENTER the message "ConV" is shown and an acoustic signal is emitted).

7.2 NET/GROSS SWITCH (ntgS)

If a tare is set by pressing the MODE key, for about 3 second interval, the gross weight is displayed.

NOTE: While the gross weight is being viewed it is not possible to print.

7.3 INPUT/OUTPUT (in out) –

Simple display functioning mode with in / out weighing function: the indicator acquires two weight values through the confirmation of the operator and calculates the difference, automatically printing the data (if the presence of a printer has been configured).

Once the in/out mode has been selected, the message "tyPE" is shown and one is asked to select with ENTER the printing mode of the acquired data:

- **G.t. gross/tare:**
 - GROSS Greater weight with unit of measure
 - TARE Lesser weight with unit of measure.
 - NET Difference between GROSS and TARE with unit of measure
- **1st.2nd first weigh/second weigh:**
 - WEIGH 2 Second weight with unit of measure.
 - NET Difference without sign between WEIGH 1 and WEIGH 2 with unit of measure.
- **in.out input/output:**
 - INPUT First weight with unit of measure.
 - OUTPUT Second weight with unit of measure.
 - NET Zero weight with unit of measure >> if WEIGH 1 = WEIGH 2
 - INPUT NET >> if WEIGH 1 > WEIGH 2
Difference without sign between INPUT and OUTPUT with unit of measure.
 - OUTPUT NET >> if WEIGH 1 < WEIGH 2
Difference without sign between INPUT and OUTPUT with unit of measure.

PROCEDURE:

- By pressing MODE key the unit acquires the first weight, on the display is shown " - - 1 - - -";
- By pressing again MODE key, the unit acquires the second weight, and on the display is shown " - - 2 - - -".
- **NOTE:** The acquisition of the second weight is made only if the setting of the rEACt parameter in the set-up environment has been respected (passage by zero of the weight instability, or always); see section 9.11 "REENABLING OF THE PRINTOUTS AND THE INDICATOR FUNCTIONS".
- When the second weight is acquired, the data printout is commanded:

It is possible to interrupt the weighing cycle by pressing the C after the acquisition of the first weight: On the display the message " CLEAR " is shown accompanied by a prolonged beep. Press ENTER to confirm the cancelling of the first acquired weight or another key to not confirm.

NOTES:

The first weight is acquired if:

- With a NON APPROVED scale one has a STABLE weight and GREATER than 0.
- With an APPROVED scale one has a STABLE weight and GREATER than 20 divisions.

The second weight is acquired if:

- With a NON APPROVED scale one has a STABLE weight and GREATER than 0.
- With an APPROVED scale one has a STABLE weight and GREATER than 20 divisions.
- if the setting of the rEACt parameter in the set-up environment has been respected (passage by zero of the weight, instability, or always); see section "REENABLING OF THE PRINTOUTS AND THE INDICATOR FUNCTIONS".
- the tare operations are DISABLED.
-

7.4 DISPLAY WITH SENSITIVITY X 10 (VISS) (TO BE USED IN TESTING DURING THE CALIBRATION)

By pressing the MODE key one switches from the weight display with normal sensitivity to a sensitivity ten times greater; in fact, one will note that the last digit on the right of the display will have a sensitivity equal to the scale's division divided by 10.

If a printout is carried out, the weight values are printed with the normal sensitivity.

7.5 HOLD: FREEZING THE WEIGHT ON THE DISPLAY (HLd)

By pressing MODE, the value of the weight is held on the display, and the display shows HoLd alternately with the weight held value (every 5 sec). To release the weight value on the display, press MODE key again.

7.6 PEAK WEIGHT PEAKS DETECTION (PEaK)

It is possible to use the instrument to store the maximum weight value measured during the weigh (PEAK), useful to measure, for example, the breaking load of the materials.

By pressing MODE the peak mode is enabled, and the display shows "PEAK" alternating with the held weight value (every 5 sec).

To stop the test and return to standard operation press MODE key again, (for an instant "PEAKoF" is displayed).

The detected weight value will be:

- The maximum before a rapid decrease of the weight (measurement of the ultimate load).
- The maximum and persistent weight detected on the scale.

SETTING SAMPLING TIME

It is possible to set the minimum time period of the peak impulse beyond which the measuring is accepted. This time is set by keeping "ENTER/PRINT" pressed for a few seconds when the indicator is not in the peak mode: the message tPI C then -tP- appears on the display followed by a number which corresponds to the minimum time length of the impulse expressed in hundredths of seconds.

By pressing “->0<- or ->T<-” the following settable values are proposed: 1, 2, 3, 4, 5, 10, 20, 50, 100, and 127; press “ENTER/PRINT” to confirm the desired value (value in 1/100 of second), the indicator will return to weighing.

The default value is 1.

7.7 HORIZONTAL TOTALIZER (Sum of lots -> tot 0)

If the unit is switched OFF, the totalizer will be reset

Tot.Mod : TYPE OF TOTALISATION (NORMAL, FAST, AUTOMATIC)

Once the totalizer operating mode is selected, both horizontal and vertical, one is asked to set the type of totalization: normal (t.norM), fast (t.FASt) or automatic (Auto); with ->0<- or ->T<- one changes the parameter; with ENTER one confirms.

- **t.norM** : In the normal totalisation, for each accumulation operation there is the display of the weigh number and the net weight total, before the printing of the data.
- **t.FASt** : In the fast one, just the display of the "-tot-" message appears on the display, before the printing of the data.
- **Auto** : In the automatic one, there is the automatic acquisition of the stable weight; therefore the display of the "-tot-" message on the display and then the printing of the data.

MAx.tot: NUMBER OF CONSECUTIVE TOTALISATIONS AFTER WHICH THE TOTAL IS AUTOMATICALLY PRINTED AND RESET

After having carried out the set weighs, the accumulated general total is printed and reset; set a value between 00 and 63.

NOTE: the value 00 disables the function

TOTALISATION OPERATIONS

In order to carry out the totalisation it is necessary to press the MODE key (if the automatic totalisation has not been set): the weight is accumulated in two total levels (a partial total and a general total).

To totalize, the net weight must be at least one division with non approved instrument and of at least 20 divisions with approved instrument.

To avoid undesired accumulations, the "MODE" key is active just once; it reactivates depending on the setting of the " rEACT " parameter in the SET-UP environment, in other words, either after passing by the net zero of the scale, by instability or always (see section "REENABLING OF THE PRINTOUTS AND THE INDICATOR FUNCTIONS").

If the presence of a printer has been configured, the "MODE" key or automatically causes also the printing of the weight values.

After a totalisation, press the MODE key again:

- with the normal totalizer, one can temporarily view on the display the number of weighs carried out and the PARTIAL NET TOTAL accumulated until that moment (Subtotal): if the accumulated digit is more than 6 digits the visualisation takes place in two stages.
- with the fast totalizer the " no.0.UnS " error message is displayed.

NOTE:

- If the gross or net weight is equal to zero, with the normal totalizer the indicator displays the accumulated total, while with the fast totalisation the "GroS.Er or nEt.Err" error message is displayed.

TOTALISATION WITH PRINTING

If the presence of a printer has been configured, upon each pressing of MODE, one prints the data programmed in step SEtuP >> SEriAL >> CoM.Prn >> Pr.ConF of the set-up environment (**TECH.MAN.REF.**), for example:

- Weigh number
- GROSS weight
- TARE weight
- NET weight

PRINTING AND ZEROING OF THE TOTALS

The instrument has two different total levels, a partial total and a general total, which increase upon each totalisation; these may be printed and zeroed independently from each other.

To print and zero the PARTIAL TOTAL one should press for a short time the ENTER key; depending on the type of totalisation, various messages will be displayed:

- With **normal totalisation** the number of weighs and the accumulated total will be displayed.
- With **fast or automatic totalisation** the message "totAL" will be displayed.

The number of weighs made and the NET WEIGHT TOTAL is printed.

To print and zero the GENERAL TOTAL one should press for a few seconds the ENTER key; depending on the type of totalisation; various messages will be displayed:

- With **normal totalisation** the number of weighs and the accumulated total will be displayed.
- With **fast or automatic totalisation** the message "G.totAL" will be displayed.

The number of weighs made and the NET WEIGHT TOTAL is printed.

NOTE:

All the values accumulated are automatically zeroed each time the instrument is turned off.

7.8 VERTICAL TOTALIZER (Sum by recipe -> tot S)

Like the horizontal totaliser but with each pressing of MODE (or automatically depend of parameter rEACT) the indicated weight is totalised and automatically tared; in this way it is possible for example to fill a container with various products and to know the total weight of the container (on the display or/and on a printer) and the total weight of all the containers weighed (on the display or/and on a printer) .

7.9 PIECE COUNTING (COUn)

In this functioning mode it is possible to carry out the reference operations in order to use the scale for counting pieces.

When the functioning mode is selected (F Mode -> FunCt -> Coun) , one is asked to set some parameters:

- **"uM.APW" : unit of measure of the average unit weight (APW).**

- Press ENTER to enter the step.
- With the ->0<- or ->T<- keys select the unit of measure (*g / kg / t / Lb*).
- Confirm with ENTER

- **"WAI.t" : sampling interval.**

Setting of the sampling time (in seconds, with a decimal); greater is the time set and more precise will the calculated APW be.

- Press ENTER to enter the step.
- Set the desired time.
- Confirm with ENTER
- Press many times the C key until the display shows the message "SAVE?".

Press ENTER to confirm the changes made or another key to not save.

COUNTING PROCEDURE

The operations to be carried out are the following:

- 1) Place the empty container on the scale and press ->T<- to tare it.
- 2) Check that the zero is on the display and press the MODE button: the counting function activates
- 3) The display suggests a REFERENCE QUANTITY. The possible options are: 5, 10, 20, 30, 40, 50, 60, 75, 100, 200.
- 4) Press "->0<- or ->T<-" the number of times needed to reach the desired sample size.
- 5) Put the quantity of pieces chosen for the SAMPLE on the scale and press ENTER to confirm or C to cancel the operation and return to weighing.

- 6) Press ENTER the display will indicate SAMPL and the indicator will calculate the **Average Piece Weight (APW)**. After a few instants (time set in parameter Wait.t) the display will indicate the quantity selected put on the platform.
- 7) Add the rest of the items to count in the container and whose value will appear on the display.
- 8) Unload the scale, the APW will remain stored in memory for the next counting of similar pieces, without having to repeat the REFERENCE operation.
- 9) By pressing the MODE key one switches from the display of the number of pieces piece (LED "SPE" on) to the display of the net weight piece (LED "SPE" off) and vice versa.
- 10) **To carry out a new reference operation**, press the MODE key and repeat the operations as describe in point 3).

NOTE: If the number of calculated pieces is greater than 999999, the display shows just the first 6 digits on the right.

PIECE COUNTING IN EXTRACTION

- 1) Load a FULL container on the scale and press "->T<-" to tare it.
- 2) Press "MODE": The display suggests various REFERENCE QUANTITIES: 5,10,20,30,40,50,60,75,100,200
- 3) Press "->0<- or ->T<-" various times until the chosen quantity is displayed.
- 4) From the container take off the same number of pieces and press "ENTER/PRINT" to confirm. The display shows "SAMPL" while the indicator calculates the Average Piece Weight. The display shows in negative the quantity extracted.
- 5) Continue the counting in extraction.

"Er.Mot" ERROR DUE TO WEIGHT INSTABILITY DURING THE SAMPLING

It may happen that during the sampling phase the weight is unstable and therefore it is not possible to correctly calculate the APW. The "Er.Mot" is shown remaining for about three seconds. One should therefore repeat the sampling operation.

MINIMUM WEIGHT OF THE SAMPLE

It is advisable to use a reference quantity equal or greater than 0,1% of the scale capacity.

In any case, the weight of the reference quantity should not create an APW lower than the two internal points of the converter (intrinsic limit of the instrument); if this condition takes place, during the sampling, the display will indicate for an instant: "Error " and the quantity put on the plate will not be accepted. One should therefore use a higher reference quantity.

PRINTING UNDER COUNTING MODE

If the presence of a printer has been configured, each time ENTER is pressed, while either weight or pieces are displayed, one prints the data programmed in the SEtuP >> SEriAL >> CoM.Prn >> Pr.ConF of the set-up environment; for example:

- GROSS weight
- TARE weight
- NET weight
- Quantity of PIECES (PCS) on the scale in that moment.
- calculated APW, expressed in the set unit of measure, with three decimal digits

Nota:

Setpoint in counting mode

Select in Setup : Conf -> output for the relays : 3 PCS and these others parameters

To change the setpoint value:

Press the key ENTER at least 3 seconds, the display shows : inP.Pmu, press the key : ->T<- to obtain inP.StP, press the key ENTER, the display shows : S.1 on and press ENTER to see the value and to change it if necessary with keys MODE,->0<- , ->T<- and ENTER (at this end use key C to return in counting mode).

Display and modification of average piece weight (APW)

It is possible to see and modify this value.

Press ENTER at least 3 seconds, the display shows : inP.Pmu, press ENTER again, and the bAPW is shown. You could modify it, if necessary with keys MODE,->0<- and ->T<-.

Attention : the value can't be displayed completely in first place, to see the whole value, use the key MODE.

7.10 SETPOINTS (2 static relays)

The IPE50 unit is available with 2 setpoints.

In the menu output, you must select for each relay the mode of functioning, the status of the contact, with or without hysteresis and the value of the setpoint.

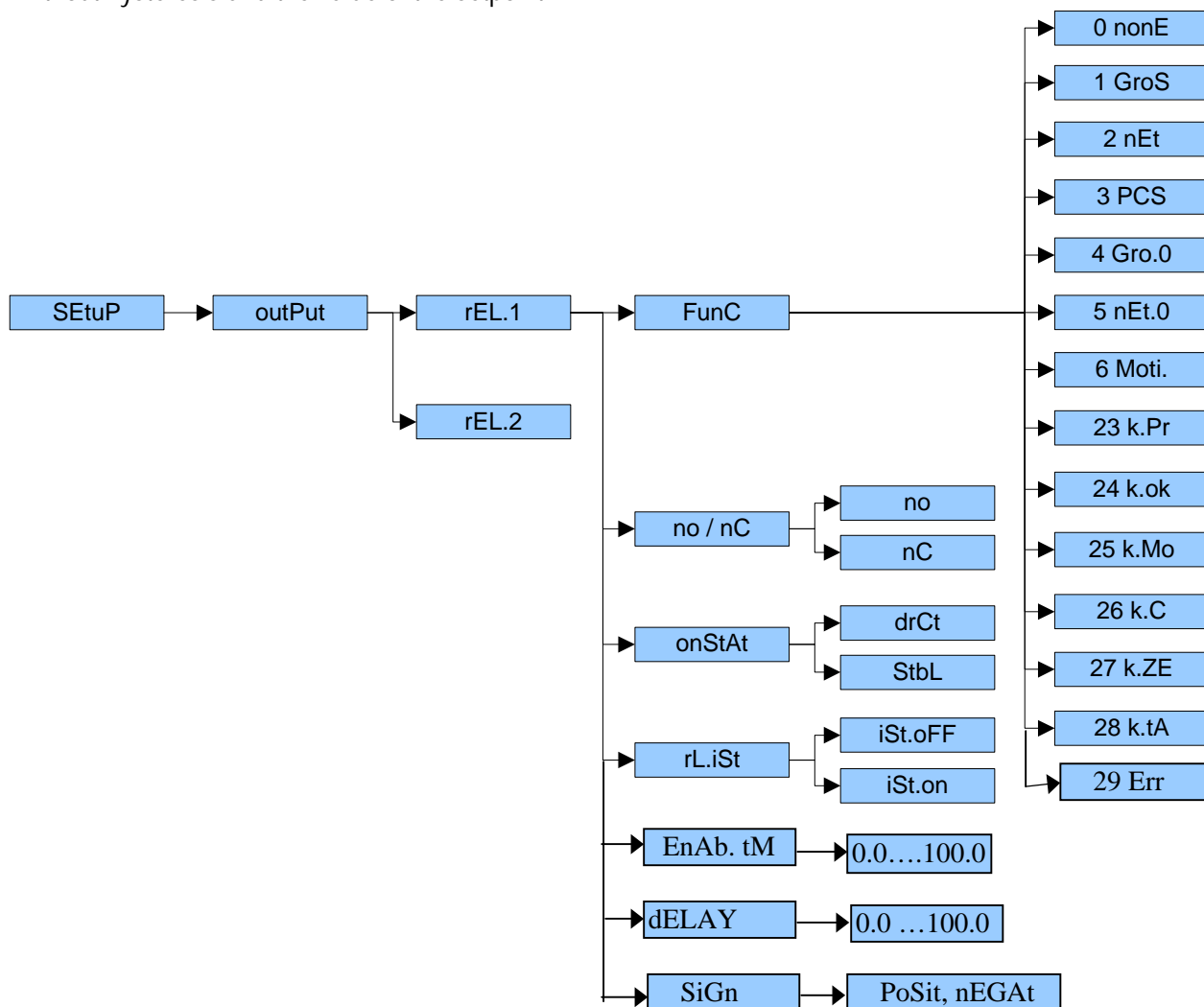

FunC : Functioning mode of the 2 setpoints (available for setpoint 1 and 2)

0 nonE : the setpoint is disable

1 GroS : setpoint on the gross display

2 nEt : setpoint on the net display

3 PCS : setpoint on the counting mode

4 Gro.O : the setpoint will be actionned when the display will be at 0 in gross value

5 nEt.O : the setpoint will be actionned when the display will be at 0 in net value

6 Moti. : the setpoint will be actionned if the display is not stable (LED ~ on)

23 K.Pr or **24 K.ok** : When you press the key "ENTER/PRINT" the contact will be closed during approximatively 2 seconds

25 .K.Mod : When you press the key "MODE" the contact will be closed during approximatively 2 seconds

26 K.C : When you press the key "C" the contact will be closed during approximatively 2 seconds

27.K.Zer : When you press the key "->0<-" the contact will be closed during approximately 2 seconds

28.K.tAr : When you press the key "->T<-" the contact will be closed during approximately 2 seconds

29.Err : the setpoint will be on if the display shows the message _ _ _ _ _ (overload) or ^ ^ ^ ^ ^ (underload)

rEL.1 or **rEL.2** : selection of setpoint 1 or 2 for programming of the parameters

no/nC : no normally opened or nC normally closed

onStAt : **drCt** the relay could change if the display is unstable / **StbL** the relay could not change if the display is stable (LED ~ off)

rL.iSt: selection without **iSt.oFF** or with **iSt.on** hysteresis

EnAb.tM : Select a time (from 0.0 to 100.0 seconds) that the relays will be on (if the display is upper than the setpoint value), after this time, the relay will switch off (even the display is upper than the setpoint value).
The value 0.0 disable this function.

DELAY : Select a time (from 0.0 to 100.0 seconds) of delay that the relays could not be on (even the display is upper than the setpoint value) after this delay, le relay could be on (if the display is upper than the setpoint value).

The value 0.0 disable this function

MODE WITH HYSTERESIS

One enters two SET POINTS for each relay: a DISABLING one, which, when the gross weight is lower than it, it disables the concerned relay; and an ENABLING one, which, when the gross weight is equal or greater than it, it enables the concerned relay.

By keeping the ENTER/PRINT key pressed for about 3 seconds one enters the DISABLING and ENABLING SET POINT values, only for the configured relays:

- The display shows " S1 on " (enable relay 1 SET POINT): press ENTER to enter the Step.
- Use the MODE key to choose the digit to be increased (BLINKING DIGIT), the scrolling of the digits goes from left to right.
- Decrease or increase the value using the ->0<- or ->T<- keys.
- When finished entering the values, confirm with ENTER
- The display shows " S1 off " (desable relay 1 SET POINT): enter the weight value like in the preceding SET POINT and confirm with ENTER
- With the C key, one quickly zeros the set point value.
- In the same way go ahead with the "Sb2.on", "Sb2.off",.
- Once finished the programming of the set points, one should exit with the C key to return to weighing.

NOTES

The 0 value is valid for the enabling and the disabling set points and just the setpoints greater or equal to zero are accepted.

- If the relay functioning mode has not been configured, the prolonged pressure of the ENTER key has no effect.
- The DISABLING SET POINT must be equal or less than the ENABLING one;
if in the DISABLING SET POINT one enters and confirms a value greater than the ENABLING one, the instrument will automatically set 0 value and wait for a correct value.
If in the ENABLING SET POINT one enters and confirms a value greather than the max capacity, the instrument will automatically set 0 value and wait for a correct value.
- The check of the weight remains active on the present value even during the modification of the SET

POINT, until the new value is confirmed.

- At start-up, the relays are managed from when the software version is displayed and these take on the configuration set in the set-up environment. These are not managed inside the set-up menu.
- The tare operations are active.

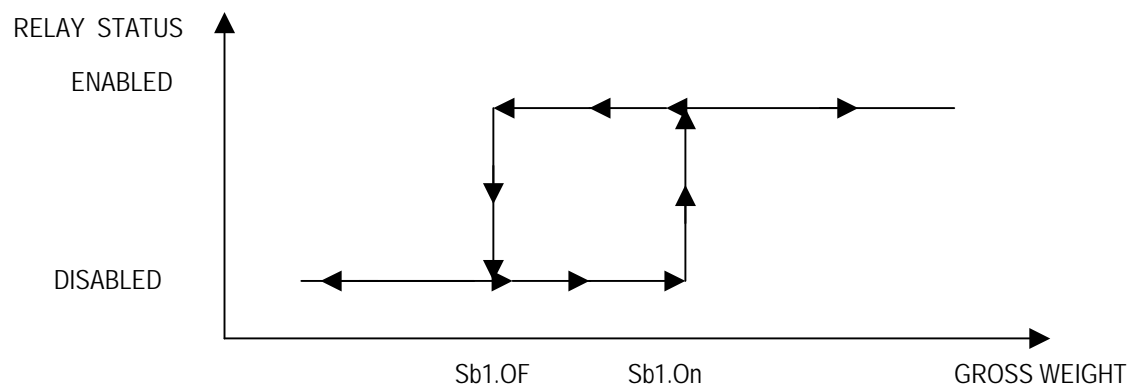

MODE WITHOUT HYSTERESIS

It is the same as the functioning mode with hysteresis, except that one enters just one SETPOINT value S.1 on and S.2 on (therefore the enabling threshold coincides with the disabling threshold).

7.11 INPUT CONFIGURATION (for the 2 inputs remote control)

In this step one sets the function to link to each input on the screw terminal

| | |
|-----------------|-----------------------|
| nonE | Disabled |
| ZErO | ->0<- Key |
| tArE | ->T<- Key |
| ModE | MODE Key |
| EntEr | ENTER Key |
| diS.kEy | DISABLING OF KEYBOARD |
| (!) nonE | |

8 INSTRUMENT MESSAGES WHILE IN USE

| MESSAGE | DESCRIPTION |
|-----------------|---|
| ----- | Message displayed when the display is higher than the max capacity programmed in calibration mode |
| ----- | Message displayed when the display is lower than the zero memorized in calibration mode |
| BuSy | Print under way (PRN serial port is occupied) or indicator waiting to transmit a printing to a PC. |
| UnStAB | One is trying to print with an unstable weight. |
| un.oVEr | One is trying to print with the weight in underload or in overload, in other words, with a weight of 9 divisions greater than the capacity or of 20 divisions below the gross zero. |
| GroS.Er | One is trying to print with a not positive gross weight (equal or less than zero). |
| Net.Err | One is trying to print with a not positive net weight (equal or less than zero). |
| LoW | Net weight less than the minimum weight provided for the printing or the totalisation. |
| no.0.unS | Weight not passed by net 0 or by instability. |
| ConV. | In standard mode, with approved instrument, one is trying to print while the instrument is converting the unit of measure. |
| no in | In the input/output mode (set as "in.out"), one is trying to acquire a second time the input weight. |
| no out | In the input/output mode (set as "in.out"), one is trying to acquire a second time the output weight. |
| no 1 | In the input/output mode (set as "G.t." or "1st.2nd"), one is trying to acquire a second time the input weight. |
| no 2 | In the input/output mode (set as "G.t." or "1st.2nd"), one is trying to acquire a second time the output weight. |
| Er.Mot | In the counting mode, the sampling has not been made because the weight is unstable. |
| Error | In the counting mode, the sampling has not been made because one should use a higher reference quantity. |

9 PRINTING EXAMPLES

| | |
|----------------|----------|
| GROSS | 8,000 kg |
| PT | 3,000 kg |
| NET | 5,000 kg |
| TICKET NR. | 11 |
| 12:41 08-01-02 | |

Indicator in Standard Mode
(UISS, Std, ntgS)

| | |
|----------------|------------|
| GROSS | 1,228 kg |
| TARE | 0,456 kg |
| NET | 0,772 kg |
| PCS | 150 |
| APW | 0,00514 kg |
| TICKET NR. | 13 |
| 12:11 08-01-02 | |

Piece Counting Mode

| | |
|--------------|----------|
| WEIGHING NR. | 00000001 |
| GROSS | 0,572 kg |
| TARE | 0,500 kg |
| NET | 1,500 kg |

| | |
|--------------|----------|
| WEIGHING NR. | 00000002 |
| GROSS | 3,000.kg |
| PT | 1,000 kg |
| NET | 2,000 kg |

| | |
|----------------|----------|
| WEIGHING NR. | 00000002 |
| TOTAL NET | 3,500 kg |
| TICKET NR. | 2 |
| 12:03 08-01-02 | |

Totalizer Mode With Register

(tot o, tot s)

| | |
|----------------|----------|
| GROSS (HOLD) | 4,664 kg |
| TARE (HOLD) | 3,044 kg |
| NET (HOLD) | 1,620 kg |
| TICKET NR. | 10 |
| 12:06 08-01-02 | |

Hold Mode

| | |
|--------------|----------|
| GROSS (PEAK) | 4,664 kg |
| TARE (PEAK) | 0,000 kg |
| NET (PEAK) | 1,620 kg |

12:06 08-01-02

Peak Mode

| | |
|----------------|----------|
| GROSS (PEAK) | 0,726 kg |
| TARE (PEAK) | 0,000 kg |
| NET (PEAK) | 1,606 kg |
| 12:09 08-01-02 | |

Peak Mode



10 INSTALLATION

To obtain the best results it is recommended to install the indicator and the platform (or transducer) in a place with the following conditions:

A flat, level surface on which to rest

Stable and vibration free

Moderate temperature and humidity (15-30°C and 40-70%).

No dust or strong vapours

No draughts

Mains power supply is restricted to 12.... 25Vdc

Make sure the platform is level or that the loading cells are resting evenly

Avoid welding with load cells installed.

When the load cells are used with assembling kits under storage bins or the like, connect the upper and lower supporting plate with a copper wire cable and then earth all the upper plates.

Use waterproof sheaths and couplings in order to protect the load cell cables.

Use a waterproof junction box to connect the cells.

The extension leads of the load cells or signal amplifiers must be screened. In addition they must be laid on their own in a raceway or metal pipe as far away as possible from the power supply cables.

Connection of the cell or amplifier cables on the electrical panel shall be independent and, if possible, connected directly to the indicator's terminal board without laying other cables in the raceway.

Install "RC" filters on the contactor coils, on the solenoid valves and on all devices producing electric disturbances.

If it is possible that condensation could form inside the weight transmitter it is advisable to leave the instrument powered at all times.

Electric protections (fuses etc.) are provided by the technician installing the instrument.

Do not install anywhere where there is the risk of explosion.

All cables must be wound at least once around the ferrite ring before being connected to the terminal board; the cable screen must be left outside of the ferrite and should be connected to the relevant ground pin.

11 BLOCK DIAGRAM

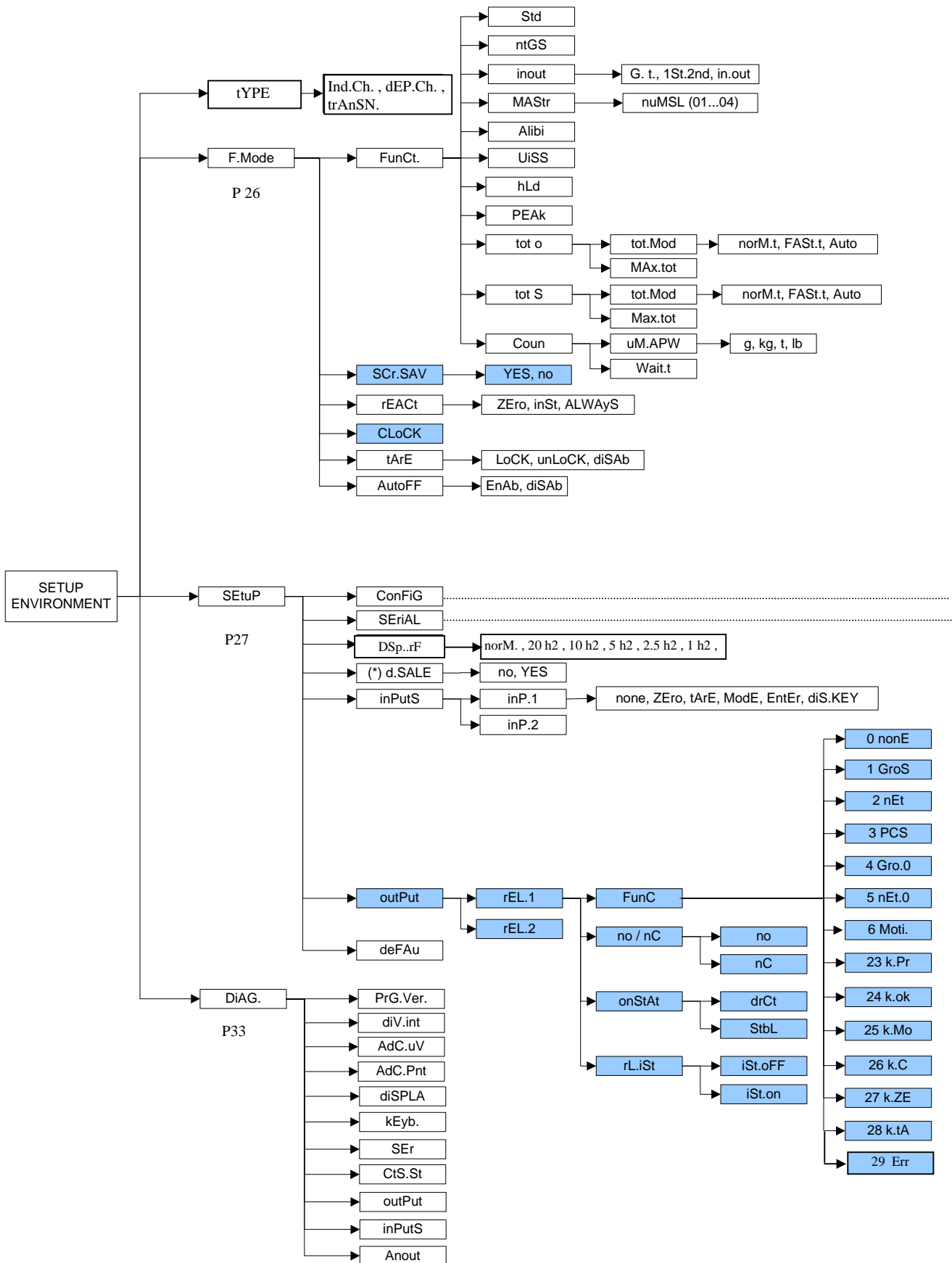

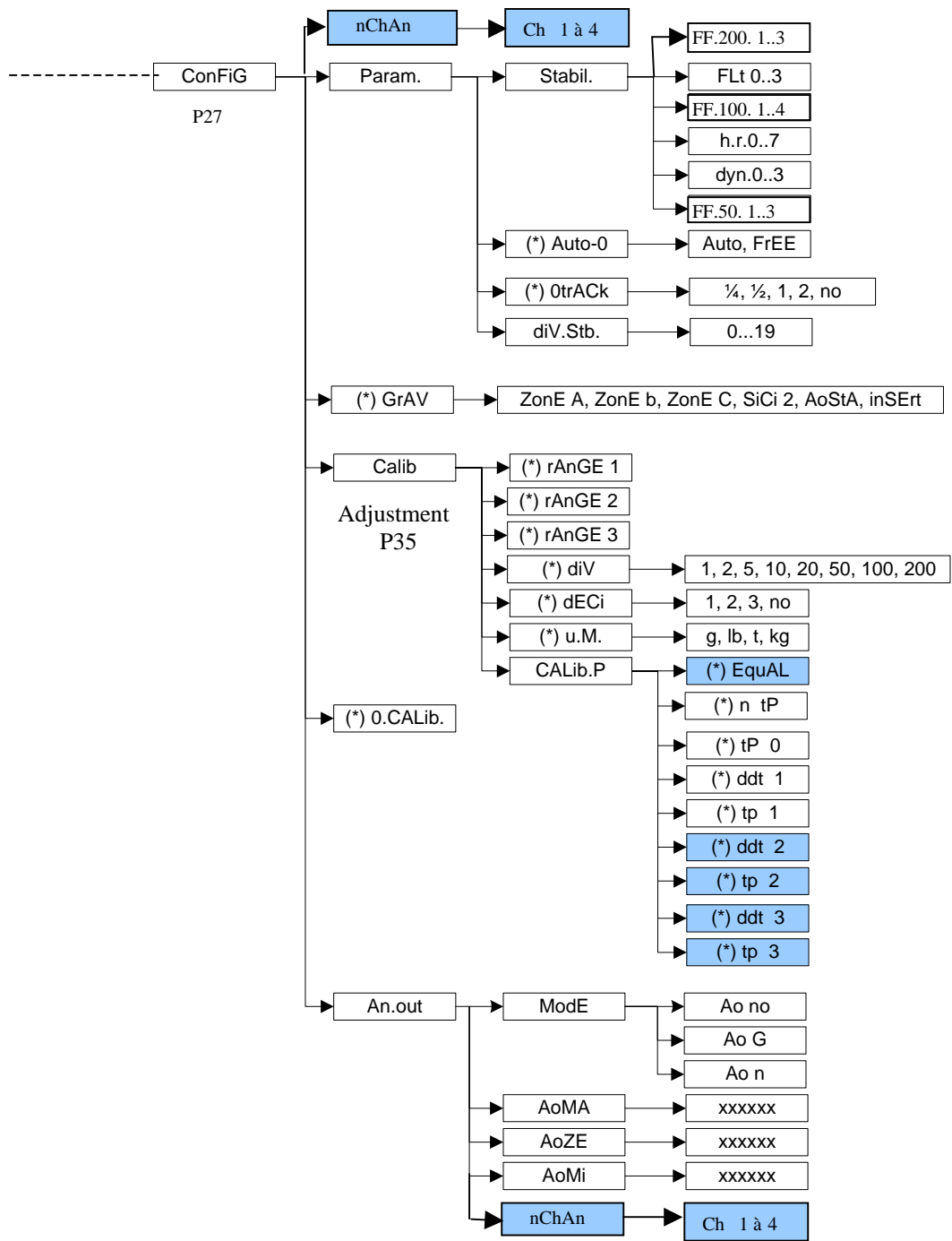

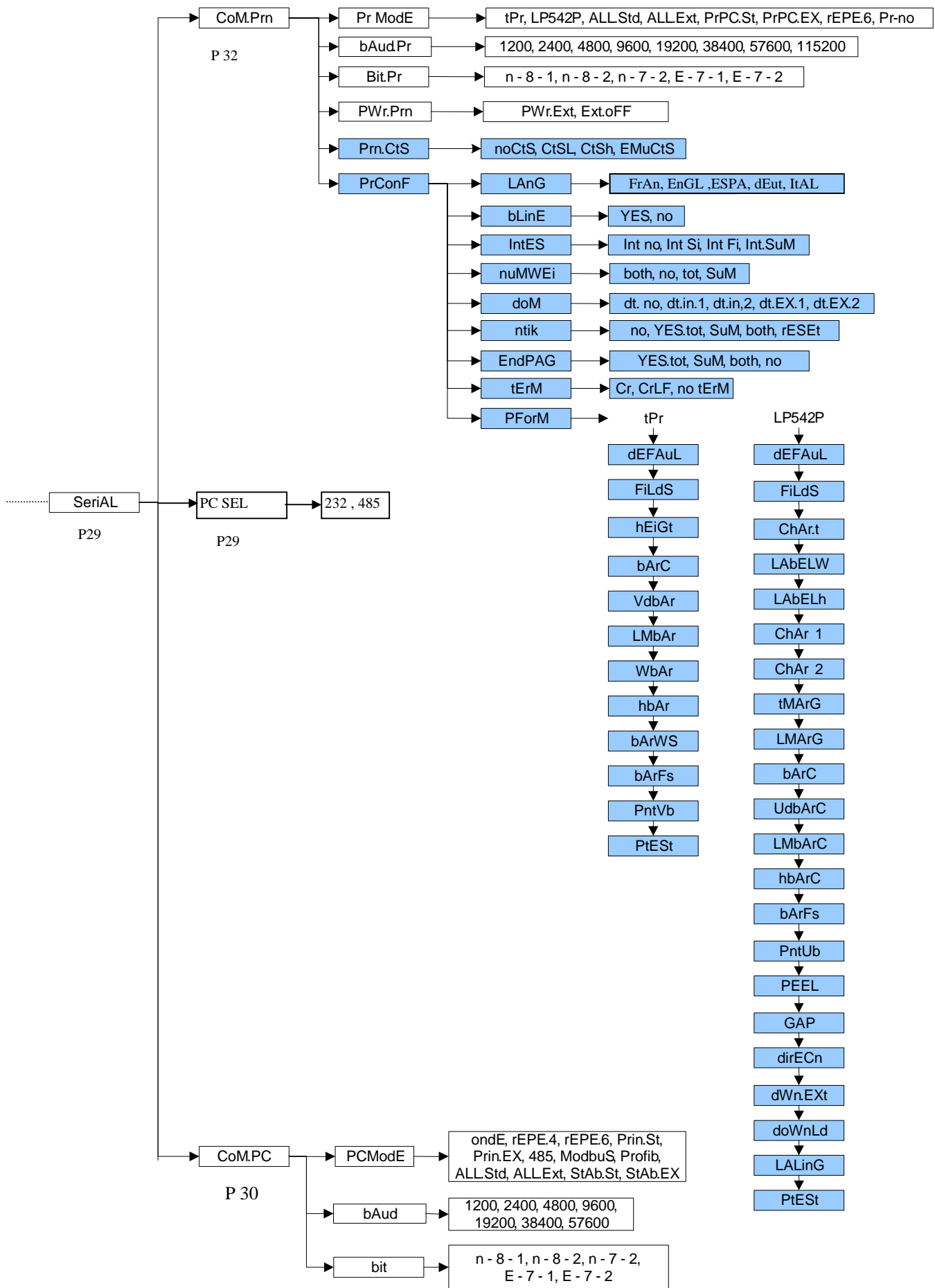

Technical Personnel Only

12 SETUP ENVIRONMENT

If the IPE50 has never been calibrated, the message Err 39 will be displayed (see page 52)

With "SETUP ENVIRONMENT" we intend a specific menu, inside which it's possible to set all the functioning parameters of the indicator.

To enter it, turn on the instrument and, during the countdown, press the ->T<- key or the ->0<- key for an instant.

The indicator shows the first parameter "F.modE".

NOTE: THE METROLOGICAL PARAMETERS of the SETUP ARE normally NOT ENABLED and therefore are just displayed. To enable them, open the instrument and activate the special microswitch (see "CONNECTIONS SCHEMES" section) and then turn it on.

If the instrument is LEGAL FOR TRADE one must first remove the legal seal on the front panel.

In the Set-Up condition, the instrument keys allow the user to perform the following functions:

| | |
|-------------|--|
| ->0<- | Scrolls the programming steps forward in sequence. |
| ->T<- | Allows to scroll backwards through the programming steps. |
| MODE | Allows to quickly position on the first step of a menu. |
| ENTER/PRINT | Allows to enter a step or confirm a parameter inside a step. |
| C | Allows to exit a step without confirming the possibly modified parameter and go to the preceding level. When entering a numeric value it quickly zeros the displayed value. |

The display indicates the abbreviation of the step whose meaning is described below. The values indicated with the (!) symbol at the end of the step, are values set by DEFAULT.

TO EXIT THE SET-UP ENVIRONMENT, PRESS THE C KEY MANY TIMES UNTIL THE INDICATOR SHOWS "SAVE?" IN THE DISPLAY: CONFIRM WITH ENTER TO SAVE ANY CHANGES MADE OR PRESS ANOTHER KEY TO NOT SAVE.

12.1 DESCRIPTION OF THE STEPS

TYPE

Ind.Ch. Standard using for 1 to 4 independant channels (selection of the channel displayed by the key "MODE" and key "->T<-" and validation with key "ENTER")

DEP.Ch. Using for the connection of 2 to 4 identical sensors on a same system

TrAnSM. same as for ind.Ch, except that the keys, the zero tracking and the autozero at the startup are disabled and it is possible with one serial command, to receive the values of all the activated channels .

F.Mode

FunCt FUNCTIONING MODE

| | |
|--------------|--|
| Std | Kg / lb conversion. |
| ntGS | Net weight / gross weight conversion. |
| inout | Input / output weigh. |
| MAStr | Master to use with 1 to 4 slaves IPE50 |
| ALibi | Not available |
| UiSS | Sensitivity times ten. |
| hLd | Hold. |
| PEAK | Peak detector. |
| tot o | Horizontal totalizer. |
| tot S | Vertical totalizer. |
| Coun | Counting. |

NOTE: If one has selected the "inout", "tot o", "tot S" or "Coun" mode one will be asked to also select a functioning parameter: see the functioning mode section for the relative description.

Once the functioning mode has been selected, one is asked to enable the standard printouts of that mode; the display shows the message "dEF.Pr?": press ENTER to enable the printouts, or C to enable just the functioning mode and not the relative printouts.

(!) Std

Scr.SAv: SCREEN SAVER

If the indicator has the date/time option, it is possible to enable the "Screen Saver" function: after a programmable time (from 1 to 255 minutes) that the scale is unloaded, the time is shown on the display, in the "HH-MM.SS" format. As soon as a weight variation is detected, or a key is pressed, the indicator displays the current weight once again.

no Disabled.

yES Enabled: one is asked to enter the time which the indicator waits to activate the screen saver, after the weight has become stable and keys are not pressed.

(!) no

rEACt REENABLING OF THE PRINTOUTS AND THE INDICATOR FUNCTIONS

While using the indicator, it is possible to incur in the "**no.0.unS**" error shown on the display accompanied by an acoustic signal; this means that the printout or the function which one wants to carry out must be reenabled (in order to avoid accidental executions).

It is possible to set the reenabling in the following modes: "passage of the net weight by zero", "weigh instability" or "always".

ZERo passage of the net weight by zero

inSt instability

ALWAYs always

(!) ZERo

CLoCK DATE/TIME ADJUSTMENT (OPTIONAL)

In this step one sets the date and time of the indicator; by pressing ENTER one is asked to enter, in this order, the day, month, year, hour and minute.

The entry of each parameter must be confirmed with ENTER

NOTE: the parameter is not displayed if there is no date/time option.

tArE t LOCKED / UNLOCKED / DISABLED TARE SELECTION

LoCK locked tare

unLoCK unlocked tare

diSAb disabled tare

See the "TARE OPERATIONS" section for further functioning details

(!) LoCK

AutoFF AUTO SWITCH-OFF

It is possible to enable the automatic switch off of the indicator (from 1 to 255 minutes), or disable it; the auto switch-off starts working when, **with unloaded scale**, the weight has not been moved or a key has not been pressed during the set time: the display shows the blinking "- oFF - " message and an acoustic signal is emitted; then the indicator turns off.

Di SAb auto switch-off disabled.

EnAb auto switch-off enabled (one will be asked to enter the number of minutes after which the indicator must turn off: enter a number from 1 to 255).

(!) di SAb

SEtuP SCALE CONFIGURATION**ConFiG (configuration)****Param. METRIC PARAMETERS*****StAbiL FILTERING INTEGRATION***

By pressing the **ENTER** key one accesses the selection of the type and degree of filter intervention for the stability of the weight indication:

| | | |
|---------|--------|--|
| FLt | 0 to 3 | filter for simple weighing |
| FF.50. | 1 to 3 | filter for dosage 50 measurements/seconde |
| FF.100. | 1 to 4 | filter for dosage 100 measurements/seconde |
| FF.200. | 1 to 3 | filter for dosage 200 measurements/seconde |
| h.r. | 0 to 7 | filter very slow for high resolution |
| dYn. | 0 to 3 | filter for crane scale |

The higher the filter value is, and greater is its intervention relative to the type of filter used.

(!) FLt 3

Nota: the filter FF.200 is not suitable in the mode **DEP.Ch.** for 3 or 4 channels

(*) Auto-0 AUTOZERO AT THE START UP

By pressing ENTER one chooses whether to enable (**EnAb**) or disable (**diSAb**) the automatic acquisition of the gross zero upon start-up. By choosing **EnAb**, if upon start-up a detected weight is within +/- 10% of the capacity, it is zeroed; if the weight is not within this tolerance, the non approved instrument's display will show the present weight after a few instants, while an approved instrument will continuously show "ZEro" on the display, until a weight within tolerance is placed.

(!) Auto

(*) 0trACK ZERO TRACKING

This menu allows setting the zero tracking, in other words, the compensation parameter of the scale's thermal drift; the set value corresponds to the number of divisions that is reset in the fixed time of 1 second.

tr. ½ +/- half division.
 tr. ¼ +/- one fourth of a division
 tr. 1 +/- one division.
 tr. 2 +/- two divisions.
 tr. no tracking disabled.

NOTE: If the indicator is approved, the step may not be modified.

(!) tr. ½

diU.Stb DIVISIONS BY STABILITY

In this step one enters the number of divisions by which the instrument detects the weight stability; the higher the number of divisions, less is the sensitivity, and consequently the stability is more easily detected. The possible values are 1...19.

NOTE: with approved instrument, it is possible to enter just the values 1 or 2; if one enters a higher value, it will be confirmed, but when returning to the step, the last stored value (acceptable) is repropose.

(!) 5

(*) GrAV GRAVITY ZONE AND ZONE OF USE

Through this step one selects the gravity zone **of calibration and of use** of the instrument.

One may manually enter the gravitational acceleration value; **one must modify just the 5 decimal digits of the gravitational acceleration.**

In case one enters a wrong g value, the minimum decimal value is suggested (9,75001); a wrong value is any decimal number that is not between 9,75001 and 9,84999 (inclusive).

NOTE: If the indicator is approved, the step can not be modified.

(!) 9.80655

CALib. SCALE CALIBRATION / ADJUSTMENT

See paragraph "ADJUSTMENT" section.

(*) 0CALib. QUICK ZERO CALIBRATION / ADJUSTMENT

See paragraph "CALIBRATION" section.

NOTE: If the indicator is approved, the step is not displayed.

An.out ANALOG OUTPUT

MODE Ao no the analog output is disable
 Ao nEt the analog output is enable and on the net value of the display
 Ao Gro the analog output is enable and on the gross value of the display

Ao MAH Adjustment of the maximum signal (ex: 10V , 20mA..)
 Ao Zer Adjustment of the signal for the display is equal at 0
 Ao Min Adjustment of the minimum signal (ex: 0V, 4mA...)
 SiGn PoSit the output will function only on the positif display
 nEGAt the output will function only on the negatif display

Nota: ajustement of the analog output P38

Serial (SERIALS, PRINTOUTS, ETC...)

PC SEL SELECTION OF THE COMMUNICATION PORT

485 The serial output 485 is the output for the bidirectional communication with PC ...

232 The serial output 232 is the output for the bidirectional communication with PC ...

CoM.Prn

PrModE TRANSMISSION unidirectional (RS232 or 485 depend of the PC SEL choice)

Pr-no transmission disabled.

tPr enables the printing with ASCII printer (for example DP190 or TP200).

LP542P enables to print with labelling machine LP542PLUS

ALL.Std continuous transmission with standard string.

ALL.Eht continuous transmission with extended string.

PrPC.St transmission of the standard string upon the pressing of the ENTER key.

PrPC.EH transmission of the extended string upon the pressing of the ENTER key.

NOTE: if the "TOTALIZER" mode (horizontal or vertical) is active, the transmission through the key is carried out by pressing the MODE key.

rEPE.6 transmission to 6-digit remote display RPA60.

(!) Pr-no

bAud.Pr SET BAUD RATE

By pressing the ENTER key one accesses the selection of the data transmission speed (measured in Baud = bit/second). The possible values are: 1200, 2400, 4800, 9600, 19200, 38400, 57600, 115200.

(!) 9600

bit.Pr SET PARITY, WORD, STOP BIT

By pressing the ENTER key one accesses the selection of the available values: n-8-1, n-8-2, n-7-2, E-7-1, E-7-2.

(!) n-8-1

Prn.CtS RTS/CTS STATUS CONFIGURATION

On the printer serial line the indicator has a CTS input (Clear To Send). A device (like a printer) that is slow in processing the data received, can interrupt the transmission temporarily using this signal.

noCtS no signal

CtSL CTS active low (for LP542, TP200, DP24 printers)

CtSh CTS active high (for DP190 printers)

EmuCtS emulation of the CTS signal: one is asked to enter the number of characters (nChrS), in 3 digits, which will be transmitted to the printer upon each transmission; then one needs to enter the waiting time in milliseconds (tiME), in 4 digits, between a transmission and another.

The TIME OUT of a printout is a minute, in other words, after a minute that the printout is blocked, it is cancelled.

NOTE: the parameter is not displayed if "Pr- no" has been selected in the "PrModE" step.

(!) noCtS

PrConF CONFIGURATION OF THE PRINTOUTS

See the "Print Programming" section for the description of all the menu's parameters.

NOTE: the parameter and all its submenus are not displayed if "Prno" has been selected in the "PWr.Prn" step or "Pr- no" in the "PrModE" step.

CoM.PC TRANSMISSION bidirectional (RS232 or 485 depend of the PC SEL choice)PCModE TRANSMISSION SERIAL OUTPUT

| | |
|-----------------|---|
| ondE | transmission on external command PC (given from PC or PLC, for example) |
| rEPE.4 | <i>transmission to 4 digit remote display.</i> |
| rEPE.6 | <i>transmission to 6 digit remote display RPA60.</i> |
| Prin.St. | transmission of standard string when the ENTERkey is pressed. |
| Prin.EH | transmission of extended string when the ENTERkey is pressed. |
| | NOTE: if the "TOTALIZER" mode (horizontal or vertical) is active, the transmission through the key is carried out by pressing the MODE key. |
| 485 | transmission with 485 protocol, by confirming with ENTER/PRINT, one is required to enter the machine code (the message "Ad485" appears for an instant): enter a value between 0 and 98. |
| Modbus | protocol MODBUS |
| Profi b | protocol PROFIBUS |
| ALL.Std | continuous transmission with standard string. |
| ALL.EHt | continuous transmission with extended string. |
| StAb.St | transmission with each weigh with standard string. |
| StAb.EH | transmission with each weigh with extended string. |
| | For the transmission modes and protocol specifications, see the "SERIAL PORTS TRANSMISSION MODES" and "TRANSMISSION PROTOCOLS" sections. |
| (!) OndE | |

bAud SET BAUD RATE

By pressing the ENTER key one accesses the selection of the data transmission speed (measured in Baud = bit/second). The possible values are: 1200, 2400, 4800, 9600, 19200, 38400, 57600, 115200.

(!) 9600

bit SET PARITY, WORD, STOP BIT

By pressing the ENTER key one accesses the selection of the available values: n-8-1, n-8-2, n-7-2, E-7-1, E-7-2.

(!) n-8-1

dSP.rF

norm (keep this parameter)

1 h2, 2.5 h2, 5 h2, 10 h2, 20 h2

(!) norm

dSALE Do not enter in this step

(!) no

inPutS INPUT CONFIGURATION

In this step one sets the function to link to each input

inP.b1 INPUT 1

| | |
|----------------|-----------------------|
| nonE | Disabled |
| ZErO | ->0<- Key |
| tArE | ->T<- Key |
| ModE | MODE Key |
| EntEr | ENTER Key |
| diS.kEy | DISABLING OF KEYBOARD |

(!) nonE

inP.b2: INPUT 2

The programming of the inputs 2 is done as described for input 1.

NOTE: In case 2 inputs are simultaneously enabled with the same function, just the input 1 is taken into consideration.

outPut RELAY CONFIGURATION (option)

In this step one sets the function to be linked to each relay (optional, 2 relays).

NOTE: the parameter is displayed only if the setpoint parameters has been selected

rEL. 1 Relay 1

FunC : Functionning mode of the 2 setpoints (available for setpoint 1 and 2)

0 nonE : the setpoint is disable

1 GroS : setpoint on the gross display

2 nEt : setpoint on the net display

3 PCS : setpoint on the counting mode

4 Gro.O : the setpoint will be actionned when the display will be at 0 in gross value

5 nEt.O : the setpoint will be actionned when the display will be at 0 in net value

6 Moti. : the setpoint will be actionned if the display is not stable (LED ~ on)

23 K.Pr or **24 K.oK**: When you press the key "ENTER/PRINT" the contact will be closed during approximatively 2 seconds

25 .K.Mod : When you press the key "MODE" the contact will be closed during approximatively 2 seconds

26 K.C : When you press the key "C" the contact will be closed during approximatively 2 seconds

27.K.Zer : When you press the key "->0<-" the contact will be closed during approximatively 2 seconds

28.K.tAr : When you press the key "->T<-" the contact will be closed during approximatively 2 seconds

29 .Err : the setpoint will be on if the display shows the message _ _ _ _ _ (overload) or - - - - - (underload)

rEL.1 or **rEL.2** : selection of setpoint 1 or 2 for programmation of the parameters

no/nC : **no** normally openned or **nC** normally closed

onStAt : **drCt** the relay could change if the display is unstable or **StbL** the relay could not change if the display is unstable (LED ~ off)

rL.iSt: selection without **iSt.oFF** or with **iSt.on** hysteresis

EnAb.tM : Select a time (from 0.0 to 100.0 seconds) that the relays will be on (if the display is upper than the setpoint value), after this time, the relay will switch off (even the display is upper than the setpoint value).

The value 0.0 disable this function.

(!) 0.0

DELAY : Select a time (from 0.0 to 100.0 seconds) of delay that the relays could not be on (even the display is upper than the setpoint value) after this delay, le relay could be on (if the display is upper than the setpoint value).

The value 0.0 disable this function

(!) 0.0

The same configurations are valid for:

rEL.b.2 RELE' 2

dEFAu INITIALIZATION OF THE INSTRUMENT

Through this step one can initialize the instrument with the subsequent activation of the default parameters. By pressing ENTER/PRINT, a confirmation message ("dFLt?") will appear: confirm again with ENTER or exit with any other key.

NOTE: The initialization of the instrument causes a cancellation of the present calibration and the activation of the default parameters. In any case if one exits the setup environment **WITHOUT CONFIRMING** the modification made, all the parameters of the last saving made will remain (including the calibration).

diAG (DIAGNOSTICS MENU)

It is a submenu inside which it is possible to check the software components and the scale hardware.

PrG.Uer CHECKING THE SOFTWARE VERSION

By pressing ENTER the instrument shows the software version in the XX.YY.ZZ. format.

diV.int CALIBRATION INTERNAL DIVISIONS OF CALIBRATION

By pressing ENTER the instrument shows the calibration internal divisions when the unit has been adjusted. Press "C" to exit this step.

AdC.uV MICROVOLTS

By pressing ENTER the instrument shows the output signal of the loadcell (in microvolts) relative to the weight on the sensor.

If more than 1 channel are activated, if you press the key ->T<- or ->0<-, you could select one of the channel (Ch1 to 4), in the mode dEP.Ch it is also possible to see the SuM of the channels

Note: The maximum voltage that the instrument accepts in input is 30 mV (30000 V); the weighing system is powered by the indicator at 5 Vdc.

A correct operation will have a value less than 30000 with a weight of full scale capacity on the weighing system.

Press C key to exit this step.

AdC.Pnt CONVERTER POINTS

By pressing ENTER the instrument shows the A/D converter points relative to the weight on the scale.

If more than 1 channel are activated, if you press the key ->T<- or ->0<-, you could select one of the channel (Ch1 to 4), in the mode dEP.Ch it is also possible to see the SuM of the channels

If this number is higher than the display can show, the message h=1 to 5 is shown and after the value of converter points.

Press "C" to exit this step.

diSPLA DISPLAY TEST

By pressing ENTER the instrument turns on all the display segments one at a time, after which it exits automatically from the step.

KEYb. KEYBOARD TEST

By pressing ENTER the instrument displays 0000; by pressing the keys one at a time, the relative codes are rebrought to the display. One exits pressing the same key three times.

SER SERIALS TEST

By pressing ENTER the instrument displays " S xy" in which x indicates the status of the printer serial port while y indicates the status of the PC serial port. Both can take on two values:

0 Serial port does not work

1 Serial port works

During the test one should shortcircuit T/+ with R/- (in the PC terminal board) and TXD with RXD (in the PRN).

Furthermore the ASCII "TEST"<CRLF> string is continuously transmitted on both the serial lines.

CtS.St TEST OF THE CTS STATUS

By pressing ENTER one views the status/level of the CTS signal of the printer (on) connected to the PRT serial port.

outPut TEST OF THE I/O EXPANSION BOARD RELAYS

By pressing ENTER the instrument displays "rEL.1" and enables relay 1 of the expansion board; press the ->0<- or ->T<- key to enable this other relay of the connected expansion boards.

Press "C" to exit this step

InPutS TEST OF THE I/O EXPANSION BOARD INPUTS

By pressing ENTER the instrument displays " i.bx-y" in which x, y indicate:

x – the input which is controlling 1, 2; to change the input which one wants to control press the ZERO or TARE keys.

y - the input status:

0 Disabled input

1 Enabled input

- communication error with I/O expansion board or board not present.

Press "C" to exit this step

Anout ANALOG OUTPUT TEST

You could simulate a value of the analog output by modification of the value.

This value can be modify between 0 to 65535, valid by ENTER/PRINT to simulate the output.

Press "C" to exit this step

13 ADJUSTMENT

Nota : if the IPE50 has never been calibrated, the message “Err 39” will be displayed, press the key ->T<- to enter into the menus.

Depending on the application, one can carry out two types of calibration: the one for the simple scale or the one for the pallet truck / hercules.

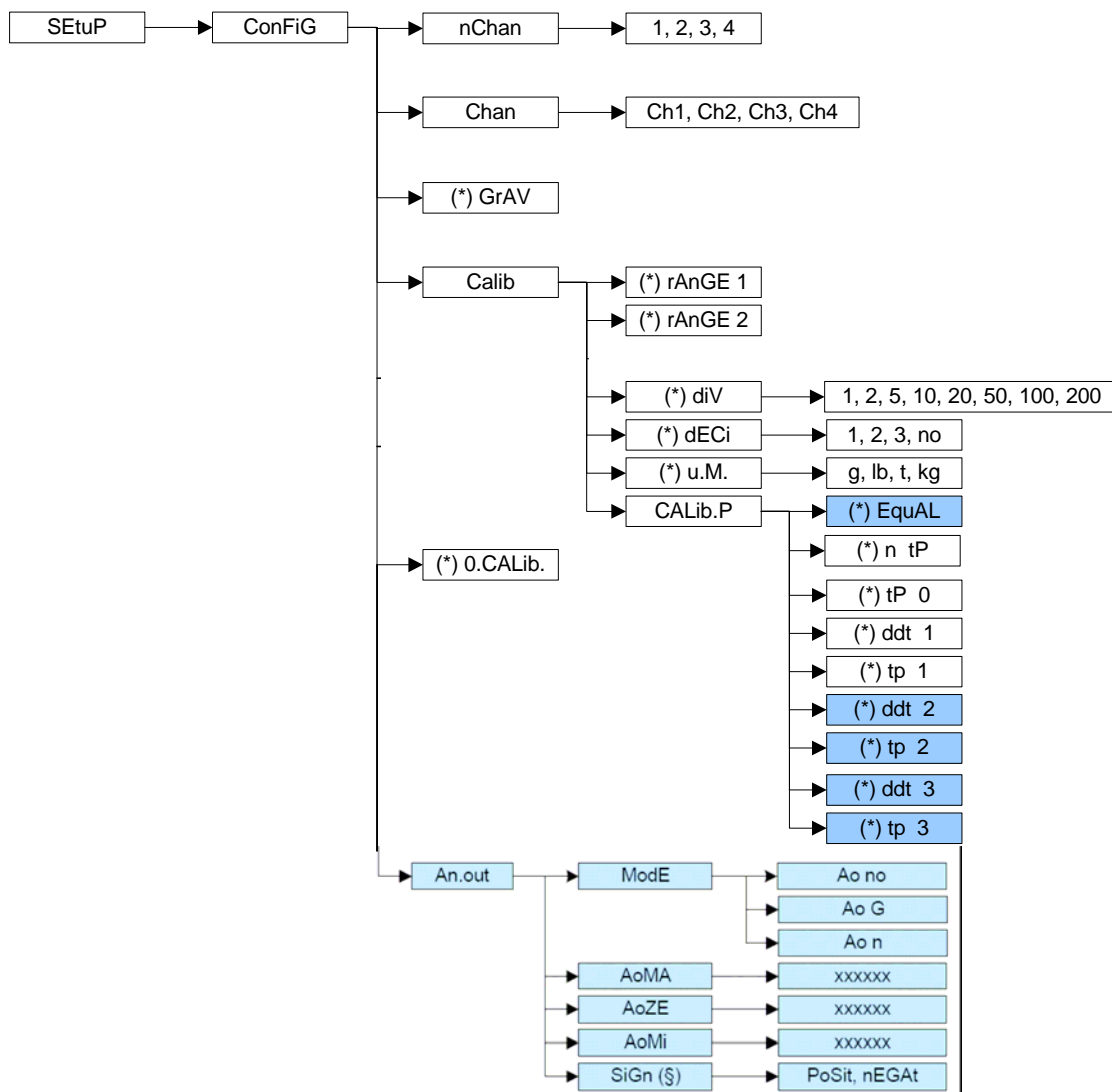

- >0<- Decreases the selected digit (blinking).
 - >T<- Increases the selected digit (blinking).
 - MODE** Selects the digit to be modified (blinking), from left to right.
 - C** Quickly zeros the displayed value.
- Valid the new value by pressing the key ENTER/PRINT.

- 1) Enter the SET-UP environment of the scale (when turned on, press the ZERO or TARE key for an instant during the countdown .
- 2) TypE is displayed.
Press ENTER/PRINT, ind.Ch. or DEP.Ch. or trAnSm. is displayed. With the key ->0<-, choose the functioning mode and press ENTER :
Ind.Ch. Standard using for 1 to 4 independ channels

DEP.Ch. Using for the connection of 2 to 4 identical sensors on a same system

TrAnSM. . idem that ind.Ch, except that the keys, the zero tracking and the autozero at the startup are disable and it is possible with one serial command, to receive the values of all the channels operating.

Type : TranSm

idem that ind.Ch, except that the keys, the zero tracking and the autozero at the startup are disable and it is possible with one serial command, to receive the values of all the channels operating.

Type : ind.Ch. (for DEP.Ch. see paragraph after)

- 3) Select the **SEtUP** (with key ->T<- then ENTER) → **ConFiG** (with key ENTER) → **CALib** (with key ->T<-) and press ENTER.
- 4) NChAn is displayed, press ENTER -> Ch x where x is the channel number which must be adjusted. (for 1 channel or 1 sensor, choose Ch 1 because the sensor must be connected in channel 1 (CELL1))
- 5) ParAM is shown, choose CALib with key ->0<- and press ENTER.
- 6) Select the "rAnGE1" step and press ENTER;
Set the total capacity of the scale or the first range in case of multirange functioning (ex: 002.000 it means maximal display of 2.000)
Confirm with the ENTER key.

Nota: the position of the decimal point will be set later , step dECI.

- 7) Select the "rAnGE2" (if the system is a simple range, SET this value to 0) and press ENTER
Set the capacity of the second range and press ENTER
- 8) Select the "diU" step and press ENTER
Set the minimum division and press ENTER (selectable values: 1, 2, 5, 10, 20, 50).
(!) 1
- 9) Select the "dECI" step (decimal point) and press ENTER
The selectable values are 1.0 (a decimal), 1.00 (two decimals), 1.000 (three decimals), 100000 (no decimal); confirm with ENTER
(!) 1.0
- 10) Select the "u.M." step and press ENTER
Set the unit of measure (g, Lb, t, kg) and press ENTER
(!) kg
- 11) Select the "CALib.P" ,calibration steps, and press ENTER
- 12) Select the "ntP" step and press ENTER
With the ->0<- or ->T<- keys set the number of points with which one wants to calibrate (from 1 to 3, with 1 it does the zero point and one weight point) and press ENTER
- 13) Select the "tP0" (scale zero point) step and recording of the signal of the loadcell: unload the scale (position "0") and wait a few seconds, then press ENTER, the unit will go automaticly to the next step after recording the sensor signal.
- 14) Select the "ddt1" (setting first reference weight) step ; press ENTER/PRINT , enter the weight value that you are applying on the loadcell and confirm with ENTER

- 15) Select the "tP1" (acquisition of first reference weight) step: put the weight (equal at the value on ddt1) on the loadcells, wait a few seconds and press ENTER, the unit will go automatically to the next step after recording the sensor signal.
- 16) **If a calibration point has been set**, once the weight acquisition has been made, the display shows for an instant the value of the internal divisions and then the "ntP" step.
If there are various calibration points, repeat the operations for the "ddt2", "tP2", "ddt3", "tP3" points.1
- 17) Once the calibration has been made of all the necessary points, press the C key various times until the indicator shows "SAVE?" in the display: confirm with ENTER to memorize and return to weighing.

N.B.: the calibration points must be increasing (point 1 < point 2 < point 3).

Type : dEP.Ch

- 3) Select the **SEtuP** (with key ->T<- then ENTER) → **ConFiG** (with key ENTER) → **CALib** (with key ->T<-) and press ENTER.
- 4) NChAn is displayed, press ENTER -> Ch x where x is the channel number which must be adjusted. (for 1 channel or 1 sensor, choose Ch 1 because the sensor must be connected in channel 1 (CELL1))
- 5) ParAM is shown, choose CALib with key ->0<- and press ENTER.
- 6) Select the "rAnGE1" step and press ENTER;
Set the total capacity of the scale or the first range in case of multirange functioning (ex: 002.000 it means maximal display of 2.000)
Confirm with the ENTER key.

Nota: the position of the decimal point will be set later , step dECI.

- 7) Select the "rAnGE2" (if the system is a simple range, SET this value to 0) and press ENTER
Set the capacity of the second range and press ENTER
- 8) Select the "diU" step and press ENTER
Set the minimum division and press ENTER (selectable values: 1, 2, 5, 10, 20, 50).
(!) 1
- 9) Select the "dECI" step (decimal point) and press ENTER
The selectable values are 1.0 (a decimal), 1.00 (two decimals), 1.000 (three decimals), 100000 (no decimal); confirm with ENTER
(!) 1.0
- 10) Select the "u.M." step and press ENTER
Set the unit of measure (g, Lb, t, kg) and press ENTER
(!) kg
- 11) Select the "CALib.P" ,calibration steps, and press ENTER
- 12) EquAL is displayed, it is used to "off-center adjustments" (corners adjustment of the load receptor)
Go to the step 16 by pressing the key ->0<- many times if you don't want to do this adjustment.
- 13) Eq0 is displayed, the load receptor must be at zero (without load), the unit will memorize the signal of the load cells, press ENTER. Eq0 blinks and after the unit will pass at the next step automatically.
- 14) Eq1 is displayed to indicate the adjustment of the loadcell which is connected to the channel 1.

Apply the load on loading point 1 (over loadcell 1) and press ENTER.

Eq1 blinks and after the unit will pass at the next step automatically.

15) Eq2 is displayed to indicate the adjustment of the loadcell which is connected to the channel 2.

Apply the load on loading point 2 (over loadcell 2) and press ENTER.

Eq2 blinks and after the unit will pass at the next step automatically.

Do the same for loadcell 3 or 4 if the channel 3 or 4 are connected to the loadcells.

When all the adjustments will be finished, the message Eq OK will display to indicate that the adjustment are finished and OK.

16) Select the "ntP" step and press ENTER

With the ->0<- or ->T<- keys set the number of points with which one wants to calibrate (from 1 to 3, with 1 it does the zero point and one weight point) and press ENTER

17) Select the "tP0" (scale zero point) step and recording of the signal of the loadcell: unload the scale (position "0") and wait a few seconds, then press ENTER, the unit will go automatically to the next step after recording the sensor signal.

18) Select the "ddt1" (setting first reference weight) step ; press ENTER/PRINT, enter the weight value that you are applying on the loadcell and confirm with ENTER

19) Select the "tP1" (acquisition of first reference weight) step: put the weight (equal at the value on ddt1) on the loadcells, wait a few seconds and press ENTER, the unit will go automatically to the next step after recording the sensor signal.

20) **If a calibration point has been set**, once the weight acquisition has been made, the display shows for an instant the value of the internal divisions and then the "ntP" step.

If there are various calibration points, repeat the operations for the "ddt2", "tP2", "ddt3", "tP3" points.1

21) Once the calibration has been made of all the necessary points, press the C key various times until the indicator shows "SAVE?" in the display: confirm with ENTER to memorize and return to weighing.

N.B.: the calibration points must be increasing (point 1 < point 2 < point 3).

13.1 ANALOG OUTPUT

This IPE50 has an analog output (0/10V or/and 4/20mA) which is automatically calibrated for the higher value (10V or 20mA) of the max capacity selected in rAnGE 1. These outputs correspond to the displayed value.

You must adjust this output through the step AoMAX and AoZEr (see step after)

It works only on a positive display if the step SiGn = PoSit (if the display is negative, the output will be the minimum value set at Ao ZEr step), It works only on a negative display if the step SiGn = nEGAt (if the display is positive, the output will be the minimum value set Ao ZEr step).

It is possible to modify these adjustments in the step : An.out

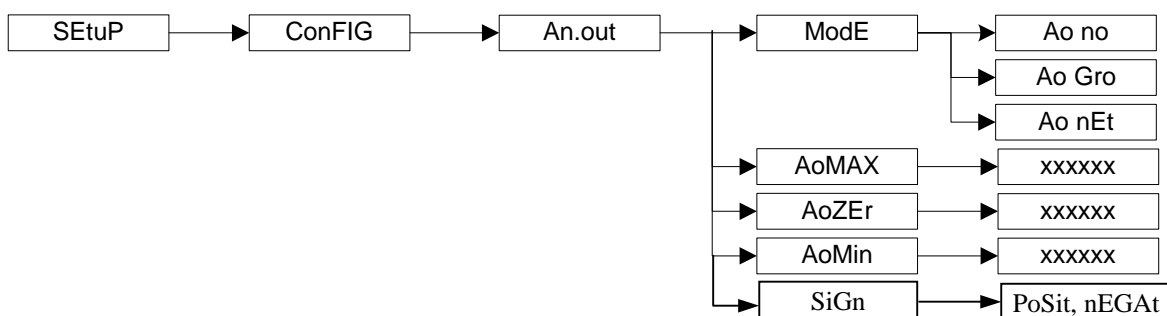

MODE **Ao no** the analog output is disable
Ao nEt the analog output is enable on the net value of the display
Ao Gro the analog output is enable on the gross value of the display

Ao MAH Adjustment of the maximum signal press key ENTER
 You could adjust the maximum value of the signal for the maximum display. The value must be set between 0 and 65535 (see chart below).
 You could modify the value with the arrow keys and confirm with ENTER key.

Ao ZEr Adjustment of the signal for the display is equal at 0
 You could adjust the minimum value of the signal for the 0 display. The value must be set between 0 and 65535 (see chart below).
 You could modify the value with the arrow keys and confirm with ENTER key.

Ao Min Adjustment of the minimum signal (ex: 0V, 4mA...)
 You could adjust the minimum value of the signal. The value must be set between 0 and 65535 (see chart below).
 You could modify the value with the arrow keys and confirm with ENTER key.

SiGn **PoSit** the output will function only on the positif display
nEGAt the output will function only on the negatif display

APPROXIMATE VALUES BETWEEN THE D/A CONVERTER AND ANALOG OUTPUT

| D/A CONVERTER VALUES | VOLTAGE VALUE (V) | CURRENT VALUE (mA) |
|----------------------|-------------------|--------------------|
| 1200 | 0 | 0 |
| 12700 | | 4 |
| 58600 | | 20 |
| 62650 | 10 | |

13.2 IN CASE THE ZONE OF USE IS DIFFERENT FROM THE CALIBRATION ZONE ONE SHOULD:

- 1) Enter in the SET-UP environment of the scale (when turned on, press for an instant the TARE or the ZERO key during the countdown).
- 2) Enter in the **SEtuP** → **ConFiG** → **GrAV** step and select the CALIBRATION ZONE.
- 3) Carry out the calibration as previously described.
- 4) Save and exit from the SET-UP environment (press many times the C key until the indicator shows "SAVE?" in the display and confirm with ENTER)
- 5) Enter the SET-UP environment of the scale and enter the **SEtuP** → **ConFiG** → **GrAV** step and select the ZONE OF USE.
- 6) Save and exit the SET-UP environment.
- 7) The weight error caused by the error of a different gravitational attraction value between the calibration zone and the zone of use is corrected automatically.

With APPROVED instrument, when turned on, the value of the zone of use or the gravitational acceleration value is displayed.

13.3 QUICK CALIBRATION OF ZERO

It is useful to calibrate just the point of ZERO when a permanent tare weight is put onto the platform (for example a roller unit).

- 1) Enter in the SET-UP environment of the scale (when turned on, press for an instant the TARE or the ZERO key during the countdown).
- 2) Enter in the **SEtuP → ConFiG → 0.CALib** step and press ENTERkey (the display shows "CAL.0?").
- 3) Put the tare on the scale and press ENTERkey to confirm the operation.
- 4) Once the zero calibration is made, press many times the C key until the indicator shows "SAVE?" in the display: confirm with ENTER to store and return to weighing.

14 SERIAL OUTPUTS

The instrument has two bidirectional serial outputs, which have the output in ASCII code compatible with the majority of printers, remote displays, PCs and other devices.

14.1 SERIAL PORT RS232 and 485 (bidirectional)

It is bi-directional (halfduplex) and uses an RS232 or RS485 for transmitting data. It is mainly used to connect computers, PLCs, additional remote displays. The transmission speed may be selected in the SET UP among these: 1200, 2400, 4800, 9600, 19200, 38400, 57600, 115200 Baud (bit/sec.).

The choice of RS232 or 485, is made by the parameter SEL PC, this other port will be unidirectional.

| | |
|------------------------|-----------------|
| Connexion RS485 | or RS232 |
| UX+ (13) | GND (17) |
| UX- (14) | RX (16) |
| | TX (15) |

The transmission of data through the PC serial port can be configured in different ways, according to the setting of the "PCMode" step in the SET-UP environment: on request, continuous, on stability .

Refer to the "TRANSMISSION MODES OF THE SERIAL PORTS" section for the functioning specifics p28.

- **TRANSMISSION REQUESTED FROM AN EXTERNAL DEVICE** ("ondE" parameter)
In this case the indicator waits for a command before transmitting (see the section "SERIAL COMMANDS FORMAT").
With Baud rate at 9600, through the READ command, it is possible to make up to 10-11 requests per second, while with Baud rate at 57600 one can arrive at 16.
The transmission works with weight <, =, > 0 with approved or unapproved instrument.
NOTE: This protocol is active also in the other functioning modes, only on the PC serial output.
- **4 – 6 DIGIT REMOTE DISPLAY TRANSMISSION** ("rEPE.4" and "rEPE.6" (for RPA60) parameter)
The weight displaying takes place both in the indicator as well as in a weight repeater of 4 or 6 digits, (normally the capacity will be properly set up for a correct displaying).
N.B. When either transmission mode is selected, the relative serial output is automatically set to 4800, N – 8 – 1.
- **TRANSMISSION WHEN THE PRINT KEY IS PRESSED** ("Prin.Std", "PrinEX" parameter)
The instrument communicates the weight data through the serial port when the ENTERkey is pressed (except for in the TOTALIZER mode where one should press the MODE key).
For non approved instruments:
The transmission takes place if the weight is stable and the net weight is > 0.
Reenabling the transmission depends on how the "rEACT" step has been set in the SET-UP environment (passing by zero of the NET weight, weight instability or always).

For approved instruments:

The transmission takes place if the weight is stable and the net weight is > 20 divisions.

Reenabling the transmission depends on how the "rEAct" step has been set in the SET-UP environment (passing by zero of the NET weight, weight instability or always).

The data is transmitted using the standard string (Prin.Std) or the extended string (PrinEX); see the "TRANSMISSION PROTOCOL" section for the description of the two strings.

- **TRANSMISSION IN RS 485 SERIAL MODE** ("485" parameter)

The protocol is the same as the transmission upon request (ondE parameter), except that the instrument responds only if its machine code is the one requested (before the request the machine code must be put, I.E. 00READ<CRLF>).

If a broadcast address command (99) is received no answer is given. If the command is correct it is executed anyways.

- **TRANSMISSION IN RS 485 MODBUS** (See special manual)

- **TRANSMISSION IN RS 485 PROFIBUS** (See special manual)

- **CONTINUOUS TRANSMISSION** ("ALL.Std" and "ALL.EXt" parameter)

This mode is used for interfacing to the PC, remote displays and other devices which request a constant updating of the data independently from the weight stability.

The instrument transmits data with each converter read operation:

- With Baud rate at 9600 one can obtain up to 10 transmissions per second.
- With Baud rate at 4800 one can obtain up to 8 transmissions per second.

The transmission works with weight <, =, > 0 with approved or unapproved instrument.

The data is transmitted using the standard string (ALL.Std) or the extended string (ALL.EXt); see the "18.5 TRANSMISSION PROTOCOL" section for the description of the two strings.

- **TRANSMISSION ON STABILITY** ("StAb.St" and "StAb.EX" parameter)

Each time a weight on the scale becomes stable, a communication string is transmitted on the PC serial port.

For non approved instruments:

- The transmission takes place if the weight is stable and the net weight is > 10 divisions.
- Reenabling the transmission depends on how the "rEAct" step has been set in the SET-UP environment (passage by zero of the NET weight or instability of the NET weight of 10 divisions; by choosing "always" it works upon instability).

For approved instruments:

- The transmission takes place if the weight is stable and the net weight is > 20 divisions.
- Reenabling the transmission depends on how the "rEAct" step has been set in the SET-UP environment (passage by zero of the NET weight or instability of the NET weight of 20 divisions; by choosing "always" it works upon instability).

The data is transmitted using the standard string (StAb.St) or the extended string (StAb.EX); see the "TRANSMISSION PROTOCOL" section for the description of the two strings.

14.2 SERIAL PORT RS232 and 485 (unidirectional)

It is unidirectional (halfduplex) , it is mainly used to connect to printers, repeater

The choice of RS232 or 485, is made by the parameter SEL PC, this other port will be bidirectional.

Please find below the various selectable serial weight transmission modes of the PC serial port through the corresponding "PCModE" StEP of the SET-UP environment.

- **TRANSMISSION TO PRINTER** ("tPr" (for TP200) and "LP542" parameter): requests the use of the print key on the indicator (prints upon request of the operator). The print command is inhibited if the weight is in motion and in all other circumstances in which the data is not valid (see "EXECUTION OF THE PRINTOUTS" section).
- **CONTINUOUS TRANSMISSION** ("ALL.Std" and "ALL.Ext" parameter): see the "ALL.Std" and "ALL.Ext" modes of the PC port.
- **TRANSMISSION OF THE PC STRING UPON PRESSURE OF THE PRINT KEY** ("PrPC.St" and "PrPC.EX" parameter): see the "Prin.St" or "Prin.EX" mode of the PC port
- **TRANSMISSION TO 6-DIGIT REMOTE DISPLAY** ("rEPE.6" (for RPA60) parameter): see the "rEPE.6" mode of the PC port.

THE CONNECTION AND THE SOFTWARE CONFIGURATION OF THE SERIAL OUTPUTS MUST BE CARRIED OUT BY TECHNICAL PERSONNEL WHO KNOW THE PROCEDURES ON THE BASIS OF THE NEEDS OF THE USER.

14.4 SERIAL COMMANDS FORMAT

Version reading command

[CC]VER<CR LF>

Instrument response:[CC]VER,vv,DGT<CR LF>

In which:vv is the firmware version

Weight read command

[CC]READ<CR LF>

Instrument response: STANDARD STRING (see "TRANSMISSION PROTOCOLS" section).

Extended weight read command

[CC]REXT<CR LF>

Instrument response: EXTENDED STRING (see "TRANSMISSION PROTOCOLS" section).

Nota: in mode Transm , the instrument response is the value of each enable channel.

Ex for 2 channels : [CC]hh,pppppppp,uu,hh,pppppppp,uu + CR + LF (ex: ST, 6.000, g,ST, 20.1,kg)

counting read command

[CC]REXTA<CR LF>

Instrument response: EXTENDED STRING for counting mode (see "TRANSMISSION PROTOCOLS" section).

Weight reading command with sensitivity times 10

[CC]GR10<CR LF>

Instrument response: STANDARD STRING : ex : ST,GX, 5.0001,kg

Reading command of microvolts relative to the weight

[CC]MVOL<CR LF>

Instrument response: STANDARD STRING : ex : ST,VT, 5.001,mV

Nota: If the IPE is configured in mode IND.Ch, and at least 2 channels are connected (on channel 1 and 2) the sensor signal transmitted will be the selected channel (see command CGCH).

If the IPE is configured in mode DEP.Ch , the value transmitted of the connected sensors are the values of each connected channel.(ex: VL, 5001 , 5520 uV * 5001 for channel 1 and 5520 for channel 2 *)

Reading command of converter points relative to the weight

[CC]RAZF<CR LF>

Instrument response: STANDARD STRING . ST,RZ, 2018206,vv

Nota: If the IPE is configured in mode IND.Ch, and at least 2 channels are connected (on channel 1 and 2) the sensor signal transmitted will be the selected channel (see command CGCH).

If the IPE is configured in mode DEP.Ch , the value will be the sum of the connected sensors

If the IPE is configured in mode DEP.Ch , the value transmitted of the connected sensors are the values of each connected channel.(ex: RZ, 255001 , 255920 uV * 255001 for channel 1 and 255920 for channel 2 *)

Tare command

[CC]TARE<CR LF> or [CC]T<CR LF> (short command).

Instrument response: [CC]OK<CR LF> if the command has been RECEIVED; the instrument's response does not mean necessarily that the instrument executes the tare.

Manual tare command

[CC]TMANVVVVVV<CR LF> or [CC]WVVVVVV<CR LF> (short command).

VVVVVV : value of the tare with comma from 1 to 6 digits

Instrument response: [CC]OK<CR LF> if the command has been RECEIVED; the instrument's response does not mean necessarily that the instrument executes the tare.

Zero command

[CC]ZERO<CR LF> or [CC]Z<CR LF> (short command)

Instrument response: [CC]OK<CR LF> if the command has been RECEIVED; the instrument's response does not mean necessarily that the instrument executes the zero.

ESC or C command

[CC]C<CR LF>

Instrument response: [CC]OK<CR LF> if the command has been RECEIVED; the instrument's response does not mean necessarily that the instrument executes the command.

The command works also within the SET-UP environment.

Channel selection (in IND.CH mode)

[CC]CGCHN<CR LF>

Instrument response: [CC]OK<CR LF>

N: the number of the channel selected (channel that will be displayed on the IPE)

Test Command

[CC]ECHO<CR LF>

Instrument response: [CC]ECHO<CR LF>.

Setpoint command (if the option is installed)

[CC]STPTntxxxxxyyyyy<CR LF>

in which: n indicates the SETPOINT number (1, 2,)

t F if the following weight value indicates the DISABLING of the relays (OFF).

t O if the following weight value indicates the ENABLING of the relays (ON). xxxxxx and yyyyyy take on the setpoint value of disabling or enabling: the digits must be entered WITHOUT the decimal point, omitting the NON significant zeros.

Instrument responses:[CC]OK<CR LF> in case of syntax and correct values.

[CC]NO<CR LF> in case of correct syntax but wrong values.

Note: if the setpoint is programmed without hysteresis, the value xxxxxx must be equal to yyyyyy.

Example of instrument with capacity 10,000 kg and division 1 g:

Command: STPT1F5000O6500 (Disabling relay 1 at 5 kg and enabling at 6,5 kg)

Response: OK

NOTE: An error response of the instrument happens in the following cases:

- one of the two entered values is greater than the capacity.
- one of the two entered values has a minimum division that is inconsistent in comparison to the one set in the instrument.
- the disabling value is greater than that of enabling.
- The command is wrong

Print Command

[CC]PRNT<CR LF> or [CC]P <CR LF> (short command).

Instrument response: [CC]OK<CR LF> if the command has been RECEIVED; the instrument's response does not mean necessarily that the instrument executes the printout.

Command for viewing temporary message on the display

[CC]DISPNNVVVVV <CR LF>

in which: NN: is the indicator display number, standard 00 (ascii hex)

VVVVVV is the message.

To cancel the message, send DISPNN or see DINT command

NOTES

In the case in which the display shown in the command is of the numeric type (for example the standard display 00), if in the transmitted message there are two consecutive points the message is stopped after the first of the two points. When the display is showing a message transmitted serially through the DISP command, the indicator does not display those messages usually shown in the scale status (ZERO, TARE, HOLD, ...).

Instrument response: [CC]OK<CR LF>

The message remains for the time set through the DINT command:

The ASCII characters having the decimal code greater than 31 are accepted.

With approved instrument:

One needs to wait the end of the current visualisation before being able to view the next one.

Command for setting display visualisation interval

[CC]DINTNNNN<CR LF>

in which: NNNN is the visualisation interval (in milliseconds), expressed in ascii hex character; for example, in order to set a visualisation time of 2 seconds (2000 milliseconds, which converted into hex it becomes 07D0), the command becomes DINT07D0<CR><LF>.

By setting a time equal to zero, the message transmitted with the DISP command remains permanently shown on the display.

Instrument response: [CC]OK<CR LF>

With approved instrument:

The minimum settable time is 1 millisecond (0001HEX), and maximum settable time is 5 seconds (5000 milliseconds, 1388 HEX).

PC confirmation command

[CC]PCOK<CR LF>

The indicator shows on the display the "-PCOK-" message for about 2 seconds.

Instrument response: [CC]OK<CR LF>.

Serial command for setting the apw (only for the counting operating mode)

[CC]SPMUvvvvvvv <CR LF> or [CC]Xvvvvvvv<CR LF> (short command).

in which: vvvvvvvv is the apw (up to 8 characters with decimal point); maximum value: 9999.999

System response: [CC]OK<CR LF>.

For example, to set a APW of 1.55 g, the command is the SPMU1.55<CR LF> or SPMU0001.550 <CR LF> and all the various combinations adding zeros to the right or to the left but taking into consideration that the

maximum length of the APW field is 8 characters.

NOTES:

- The APW are not accepted in the SPMU.12<CRLF> format; these must be in the SPMU0.12<CRLF> format.
- the APW are not accepted equal to zero.

Serial command which supplies the indicator status

[CC]STAT<CR LF>

Instrument response:

[CC]STATXX<CR LF>

in which XX is a decimal value which supplies the status of the indicator; the possible values are:

| XX | indicator status |
|-----------|-----------------------------------|
| 00 | normal scale status |
| 01 | normal scale status in input |
| 02 | instrument in technical set-up |
| 04 | in boot phase |
| 05 | in rx/tx set-up phase |
| 06 | in test phase of the serial ports |
| 07 | in print test |
| 08 | in firmware update phase |
| 09 | in stand-by |
| 10 | in automatic zero phase |
| 12 | in optoisolated inputs test phase |

Key pressure simulation command

[CC]KEYPXX<CR LF>

in which XX is the code of the pressed key:

00: ->0<- key; 01: ->T<- key; 02: MODE key; 03: ENTER/PRINT key; 04: C key;

Instrument response: OK<CR LF>; accepted command.

In case the simulated key has two linked functions (key briefly pressed or at length, like the TARE key), if the KEYP command is followed by the release command of the (KEYR) key within a maximum time of 1,5 seconds, the simple function will be executed (key briefly pressed); otherwise the second function will be made (key pressed at length).

NOTA: The instrument does not transmit the OK answer to the following short commands: P, Q, T, W, X, Z.

LEGEND

[CC]= instrument code, e.g.. 00 (only with RS485 protocol).

<CR LF>= Carriage Return + Line Feed (ASCII characters 13 and 10).

SERIAL ERRORS

Upon each serial command received the instrument transmits a response which may be a response to a command (see the command description) or the indication of the command error:

ERR01<CR LF> it is shown when a correct command is transmitted from the PC to the indicator however it is followed by letters inserted involuntarily (I.E.: READF TARES...).

ERR02<CR LF> it is shown when a correct command is transmitted from the PC to the indicator, but containing wrong data.

ERR03<CR LF> it is shown when an unallowed command is transmitted. It may be a command not used in the selected functioning mode or the command reaches the indicator in the instant in which the keyboard buffer is already occupied by another command.

ERR04<CR LF> it is shown when an inexistent command is transmitted.

14.5 TRANSMISSION PROTOCOLS

The weight data transmission on the PC and PRT serial ports may take place in two formats:

14.5.1 STANDARD STRING

[CC]hh,kk,pppppppp,uu + CR + LF

in which: **[CC]** INSTRUMENT CODE IN THE FORMAT OF TWO ASCII DECIMAL DIGITS ONLY IN THE CASE THAT THE 485 PROTOCOL IS SELECTED (FOR EXAMPLE 00).

| | | | |
|-----------|----|------------|--|
| hh | UL | Underload | |
| | | OL | Overload |
| | | ST | Stability of the display |
| | | US | Unstability of the display |
| | | TL | Active inclination input |
| kk | NT | Net Weight | |
| | | GS | Gross Weight |
| | | GX | Gross weight with sensitivity times 10 |
| | | VL | Value in microvolts relative to the weight |
| | | RZ | Value in converter points relative to the weight |

pppppppp 8 digits (including any sign and decimal point) which identify the weight. The insignificant digits are filled with spaces. Through the MVOL and RAZF command the indicator transmits the relative value on 10 digits instead of 8.

| | |
|-----------|---|
| uu | Unit of measurement "kg" "bg" "bt" "lb" "mv" (microvolts) "vv" (converter points) |
| CR | Carriage Return (13 ascii decimal character). |
| LF | Line Feed (10 ascii decimal character). |

The transmitted weight is the GROSS weight (GS) if no TARE WEIGHT has been entered; otherwise, the NET WEIGHT (NT) will be transmitted.

14.5.2 EXTENDED STRING

[CC]B,hh,NNNNNNNN,YYTTTTTTTT,PPPPPPP,AAAA.AAAA,uu + CR + LF

in which: **[CC]** INSTRUMENT CODE IN THE FORMAT OF TWO ASCII DECIMAL DIGITS JUST IN CASE THE 485 PROTOCOL IS SELECTED (FOR EXAMPLE 00)

B scale number (1 in scale mode, 0 in pallet truck scale mode).

| | | |
|-----------------|---|--------------------------|
| hh | UL | Underload |
| | OL | Overload |
| | ST | Stability of display |
| | US | Instability of display |
| | TL | Active inclination input |
| NNNNNNNN | net weight on 8 characters including possible sign and decimal point | |
| YY | "PT" if the tare is manual, otherwise YY = " " (two empty spaces) if the tare is semiautomatic. | |
| TTTTTTTT | tare weight on 8 characters including possible sign and decimal point. | |

| | |
|--------------------|--|
| PPPPPPP | number of pieces on 8 characters, equal to 0 if the indicator is in a functioning mode other than the counting mode. |
| AAAAA.AAAAA | In the counting mode, 10 digits with 5 decimals If you the unit is not in this mode , the value is equal at 0.00000 |
| uu | Unit of measure "Kg" "g" "t" "lb |
| CR | Carriage Return (13 ascii decimal character) |
| LF | Line Feed (10 ascii decimal character) |

The insignificant digits of the net, tare, gross tare weights and the pieces of the various channels will be filled with spaces (space character, 32 decimal ascii code character)

LEGEND:

b space character, 32 decimal ascii character.

15 PROGRAMMING THE PRINTOUTS

If in the set-up environment the presence of the printer has been configured correctly, the indicator carries out the print functions; each functioning mode has specific printouts, shown in the "Print examples". In any case, it is possible to define some printing fields, the size of the characters, a heading and other options depending on the printer and the predefined functioning mode.

In the "Pr.Mode" step of the set-up environment it is possible to select whether to print on the TP200 printer or the LP542PLUS labeller; see the following steps for all the printing options.

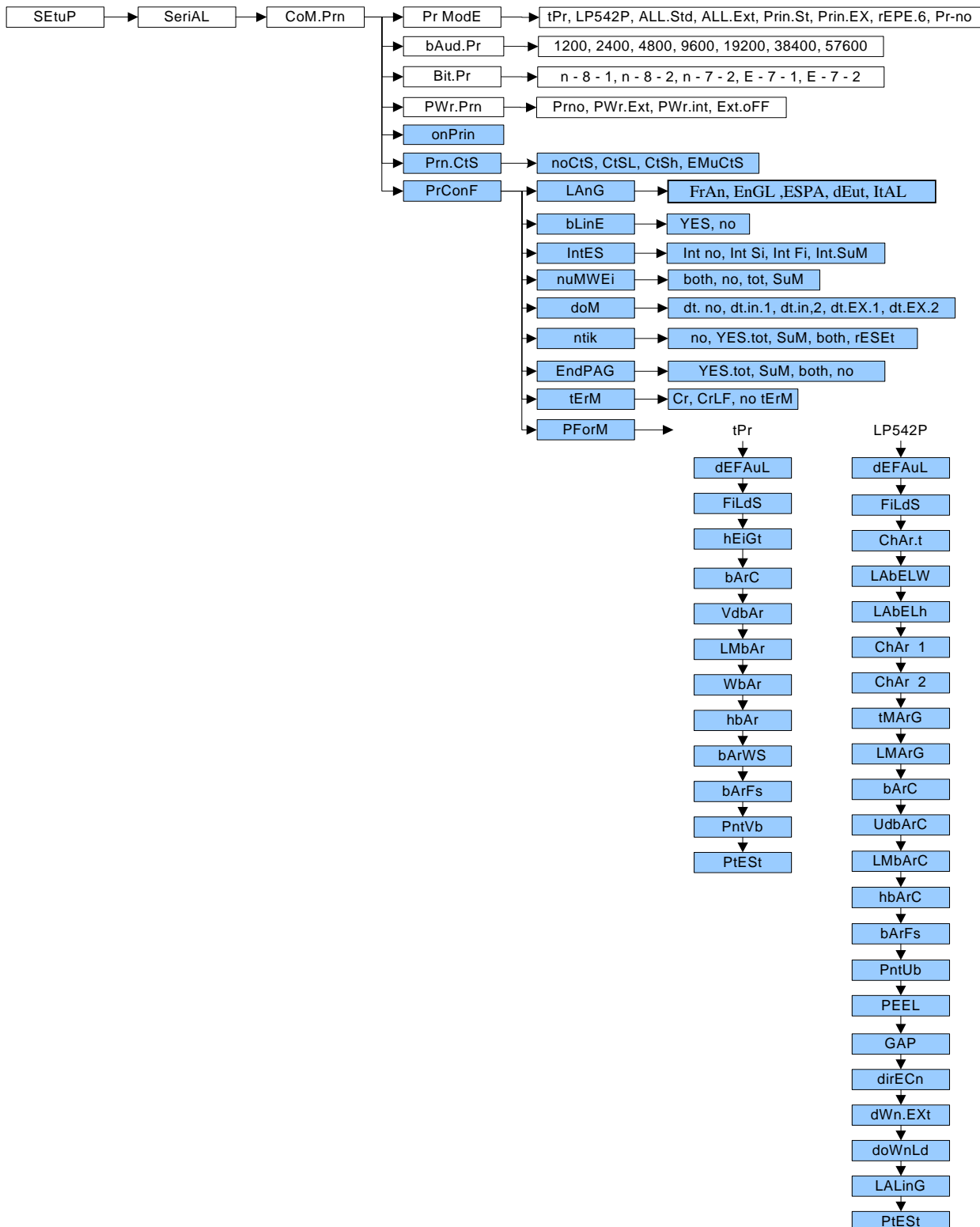

- 1) Enter the SET-UP environment of the scale (when turned on, press for an instant the ZERO or TARE key during the countdown).
- 2) Select the **SEtUP** → **Com.Prn** → **PrMode** step and press ENTER
- 3) Select the desired printer ("tPR" or "LP542P) and press ENTER
- 4) In the "SET-UP ENVIRONMENT" section see the descriptions of the "baud.Pr", "Bit.Pr", "PWr.Prn", "on.Prn" and "Prn.CtS" steps for configuring the baud rate, the number of transmission bits, the printer's power supply and the CTS signal.
- 5) Select the "**Pr Conf**" step and press ENTER/PRINT: one enters the **PROGRAMMING MENU OF THE PRINTOUTS**. Below is the description of the steps.
- 6) Once the setting have been made, press the C key various times until the indicator shows "SAVE? In the display: confirm with ENTER to memorize and return to weighing.

PrConF CONFIGURATION OF THE PRINTOUTS

In this step one enters the print programming submenu.

NOTE: the parameter and all its submenus are not displayed unless the "Prno" parameter has been selected in the "PWr.Prn" step or "Pr- no" in the "PrModE" step.

LanG PRINTING LANGUAGE

One selects the language in which the printouts are carried out:

ItAL italian.

EnGL english.

dEut german.

FrAn french.

ESPA spanish.

bLinE EMPTY LINE AT THE BEGINNING OF THE PRINTOUT

YES at the beginning of each printout an empty line is inserted.

no no empty line.

(!) YES

IntES PRINTING OF HEADING

Not available

(!) Int no

nuMWEi PRINTING OF NUMBER OF WEIGHS (ONLY FOR TOTALIZER MODE)

no does not print the number of weighs.

tot prints the number of weighs only in the single totalisation.

Sum prints the number of weighs only in the partial total.

both prints the number of weighs in the totalisations as well as in the partial total.

NOTE: the parameter is displayed only if the "totalizer" functioning mode has been selected.

(!) both

dOM PRINTS DATE AND TIME

dt. no the date and time are not printed.

dt.in.1 the date and time are printed using the clock inside the printer; in the totalizer functioning mode the date and time are printed just in the total and not in the single totalizations

dt.in.2 as above, but in the totalizer functioning mode the date and time are printed also in the single totalizations.

dt.EX.1 like "dt.in.1" but the indicator's date and time board (optional) is used.

dt.EX.2 like "dt.in.2" but the indicator's date and time board (optional) is used.

NOTE: The date and time is printed, if programmed, before the possible barcode, which is always at the end of the printout

(!) dt. No

ntik PRINTS TICKET NUMBER

The ticket number is a sequence number which increases upon each printing made, this number, between 1 and 65535, is kept in memory also when the instrument is turned off.

no does not print the ticket number.

yes.tot prints the ticket number; in the totalizer functioning mode it is printed only in the single totalisations.

SuM prints the ticket number; in the totalizer functioning mode it is printed just in the partial total.

both prints the ticket number; in the totalizer functioning mode it is printed in the totalisations as well as in the partial total.

rESet by pressing ENTER the sequence number in the ticket is zeroed.

NOTE: The ticket number, if programmed, is printed after the weight data.

(!) no

EndPAG SELECTION OF PAGE END PRINTING

This step allows to print 2 empty lines at the end of each printout (if "DP190" is selected in the "PrModE" step) or an end label (if "LP542" is selected in the "PrModE" step).

no does not print the page end

yes.tot prints the end page; in the totalizer functioning mode it is printed just in the single totalisations.

SuM prints the end page; in the totalizer functioning mode it is printed just in the partial total.

both prints the end page; in the totalizer functioning mode it is printed in the totalisations as well as in the partial total.

(!) yes.tot

tErM SETTING TERMINATOR

When connecting a printer it is often necessary to transmit one of the following protocols in order to define the end of the print line.

Cr CR (for CUSTOM, LP522/542P)

CrLF CR LF (for EPSON LX300 and TMU295).

(!) Cr

PForM PRINT FORMATTING

In this step one enters a submenu for selecting the weight data which one wants to print and the print layout.

Depending on the type of printer selected in the PrModE step (LP542P or tPr), the parameters which are suggested, change:

***** **TPr (for TP200 printer)** *****

DEFAuL PRINTOUT DEFAULT

Through this StEP one enables the default printing relative to the selected functioning mode.

The default sets, in each of the following steps, the value marked with the **(!)** symbol.

FiLdS PRINTING FIELDS

Through this StEP it is possible to select which fields to be printed among those available:

G; n; t; G n; G t; n G; n t; t G, t n; G n t; G t n; n G t; n t G; t G n, t n G (in which G is the gross weight; n is the net weight and t is the tare weight).

(!) G t n

hEiGt FONT HEIGHT SELECTION FOR PRINTING THE WEIGHT DATA, DATE AND TIME, PROGRESSIVE NUMBERS AND ID'S:

- ChAr 1** normal height
ChAr 2 double height
(!) ChAr 1

bArC PRINTS THE BAR CODE

In this step one programmes the printing of the 39 CODE (if "TPR" has been selected in the "PrModE" step), which will be printed before the printing of the date and time:

- no** does not print the bar code.
yes.tot prints the bar code; in the totalizer functioning mode it is printed just in the single totalisations.

SuM prints the bar code; in the totalizer functioning mode it is printed just in the partial total.
both prints the bar code; in the totalizer functioning mode it is printed in the totalizations as well as in the partial total.
(!) no

NOTES:

- the weight values are expressed in 6 digits without decimal point and with the possible non significant zeros present.
- between a weight value and the following one a space is inserted.
- the bar code is printed as the last data, after the weight values, possible numeric codes and ticket number, but before the date and time (with TP200 printer).

THE FOLLOWING PARAMETERS ARE VISIBLE ONLY IF IN THE PREVIOUS STEP A PARAMETER DIFFERENT FROM "no" HAS BEEN SET.

VdbAr SELECTING THE BAR CODE'S VERTICAL DISTANCE OF THE PRECEDING TEXTS:

In lines with normal height font, programmable value: 0...9. **(!) 0**

LMbAr SELECTION OF LEFT MARGIN

Expressed in 1/8 of a mm (from 0 to 99). **(!) 00**

WbAr SELECTION OF BAR CODE FONT WIDTH:

Programmable value: W1...W3
(!) W1

hbAr SELECTION OF BAR CODE FONT HEIGHT:

Expressed in 1/8 di mm (from 0 to 255) **(!) 000**

bArFS SELECTION OF PRINT FIELDS IN THE BAR CODE:

Programmable value: G; n; t.

In which G is gross weight, n is net weight and t is tare weighing.
(!) G

PntVb PRINTING OF THE BAR CODE'S NUMERIC FIELD

This step allows to select the printing of the bar code's numeric field:

- no** the numeric field is not printed.
undEr under the bar code
AboVE above the bar code
Ab/un both above as well as below the bar code.

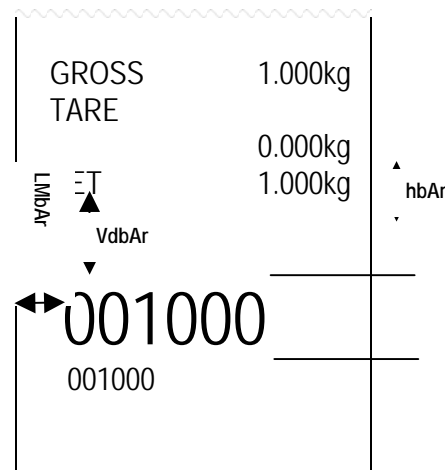

16 ERROR MESSAGES

While using the indicator, it is possible to incur in the following errors:

| MESSAGE | DESCRIPTION |
|--|---|
| PREC. | It is displayed if one tries to calibrate a point without first having confirmed the number of calibration points |
| ERMOT | Weight unstable during the acquisition of a point during calibration. |
| ERPNT | During the acquisition of a calibration point a null value has been read by the converter. |
| Er - 11 | Calibration error: a too small sample weight has been used; it is advisable to use a weight equal to at least half of the scale capacity. |
| Er - 12 | Calibration error: the acquired calibration point (tP1 or tP2 or tP3) is equal to the zero point (tP0). |
| Err - 2.1 Err - 3.1 Err - 4.1 | Err-x.1 you don't program the capacity of the channel x or there was an error on the calibration parameters of the channel x. |
| Er - 37 | The converter points are less than the instrument's internal divisions. |
| Er - 39 | It is displayed when the instrument has not yet been calibrated and initialized. press the ->T<- key when the instrument displays "ERR - 39" to enter the technical set-up environment (with the standard procedure it is not possible) programming of all the parameters of the set-up environment and the calibration. |
| C.Er.-36 | During the calibration some internal negative points have been calculated: - the calibration point is less than the zero point - the signal is negative (check the connections) |
| C.Er.-37 | During the calibration some internal points less than the minimum value have been calculated: - The calibration point is equal to the zero point - A capacity too high in relation to the division has been set |
| HW-Err | Hardware error. Software not compatible with the installed hardware. The hardware expansion is missing which allows the software to function. |

17 ELECTRICAL CONNECTION

With the connector CELL1, it is possible to connect a sensor with 4 or 6 wires (with regulation of the sensor power supply).

The connectors CELL 2 to 4, the regulation of the sensor power supply can't work (there is only 4 connection)

You must connected at least one sensor on CELL1.

18 CONNECTION SCHEMES

Sensors 14
4 wire connection only

Sensor 1 / 6 wire connection
1 sensor must be connected on this channel

LOAD CELL 2, 3, 4

LOAD CELL 1

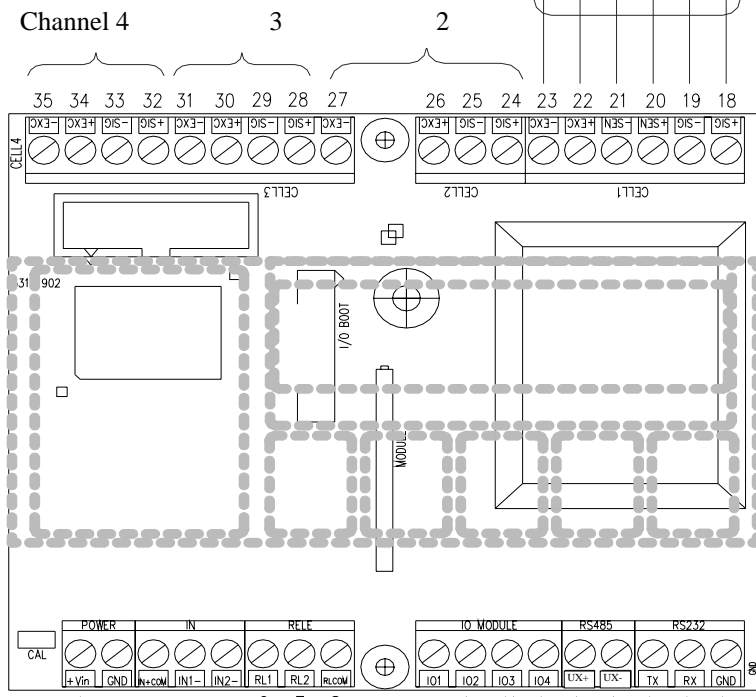
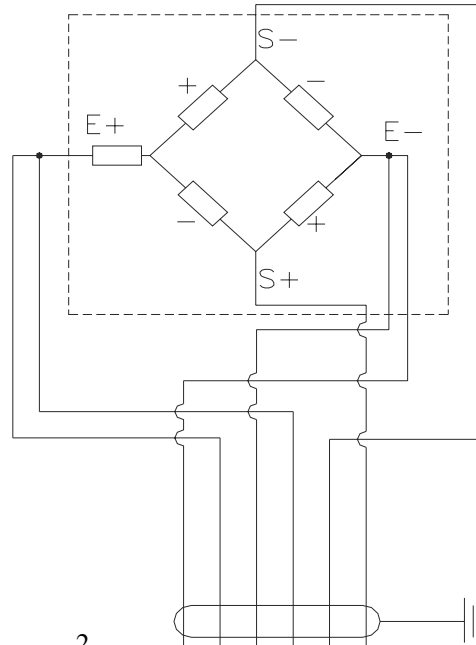
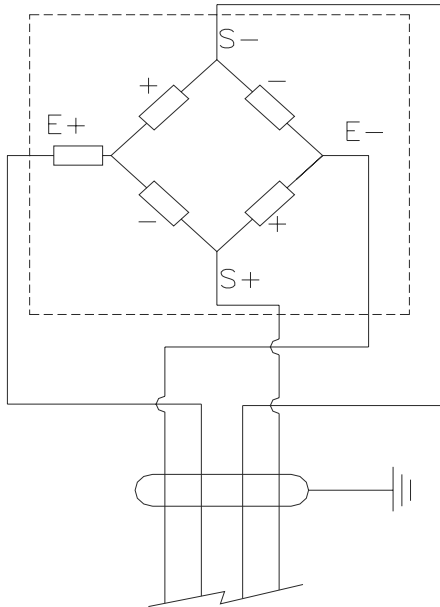

Channel 1
You must connect at least 1 sensor

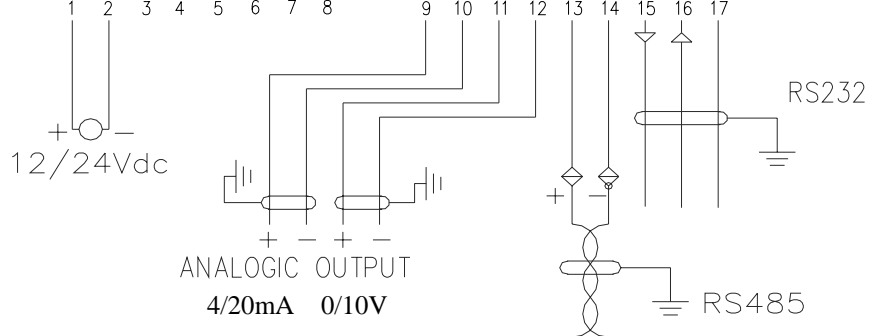

Connections

POWER SUPPLY 24 Vdc

| | |
|----------|---------------------------|
| 1 +24Vdc | + 12 to 25Vdc / 3.6 W max |
| 2 GND | - 0 Vdc |

Sensor : becarefull, the power supply of the sensors (5Vdc) is the same for the 4 channels and the maximum power is 120mA (for all the channels) for example 8 sensors 350 Ohm connected on a same channel or on 4 channels.

Channel 1 for sensor 4 or 6 wires (at least 1sensor must be connected to this channel)

| | |
|----------|--------------|
| 18 +SIG | + SIGNAL |
| 19 - SIG | - SIGNAL |
| 20 +SEN | + SENSE |
| 21 - SEN | - SENSE |
| 22 + EXC | + EXCITATION |
| 23 - EXC | - EXCITATION |

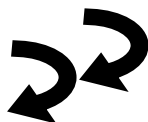

For a 4 wires sensor, please make 2 jumpers between +EXC and +SEN , -EXC and -SEN

Channel 2 to 4 for 4 wire sensor

| | |
|-------|--------------|
| +SIG | + SIGNAL |
| -SIG | - SIGNAL |
| + EXC | + EXCITATION |
| - EXC | - EXCITATION |

CAL closed : legal mode

PC PORT SERIE

RS485

| | |
|----|-----|
| 13 | UX+ |
| 14 | UX- |

PNR PORT SERIE

RS232

| | |
|----|-----|
| 15 | TX |
| 16 | RX |
| 17 | GND |

(2) static relays contact (power : 48Vdc / 100mA)

| | |
|---|-----------------|
| 8 | contact commun |
| 7 | contact relay 2 |
| 6 | contact relay 1 |

(2) opto-insulated inputs

| | |
|---|---|
| 3 | + COM (+ power supply 12 to 24Vdc / 20mA) |
| 4 | -IN (- input 1) |
| 5 | -IN (- input 2) |

Analog output optoisolated (0/10V and 4/20mA)

Current (4/20mA) (max load : 300Ω)

| | |
|----|---|
| 9 | + |
| 10 | - |

Tension (0/10V) (min load : 10KΩ)

| | |
|----|---|
| 11 | + |
| 12 | - |

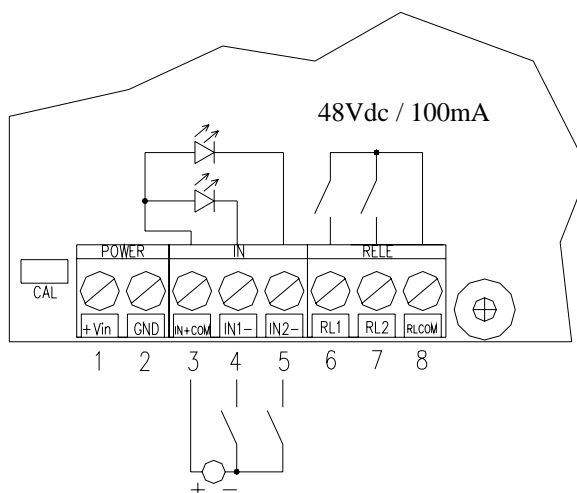

Power supply 12 to
24Vdc / 20mA

PROFIBUS version

(with this version the analog output is not possible)

