

Pressure Gauge MAN-90

PressureSCAN



Application

- hygienic pressure measurement

Application Examples

- locale display without power supply

Hygienic Design / Process Connection

- direct connection for TriClamp, SMS, IDF, DIN 11851 and Varivent
- CIP- / SIP cleanable up to 140°C / max. 60min
- sensor materials and actuating fill are FDA conform
- IP66, housing for optimized cleanability

Features

- complete device is certified by 3A
- works up to 120°C
- at option MAN-90p: Ra<0,2µm and autoclaveability is standard

Options

- case filling with glycerin for damping
- hydromechanical damping for strong pressure surges
- actuating fill with neobee M20
- special version for pharmaceutical applications(MAN-90p)
- adjustment of zero and span

Specification

Material	diaphragm	1.4404 (316L)
	fitting	1.4404 (316L)
	bourdon tube	bronze
	movement	brass
	case	1.4301 (304)
	inspection window	polysulfone*
Surface roughness	diaphragm	Ra<0,8µm
Protection class		IP66
Actuating fill	standard	paraffin oil
	option	neobee M20 (all FDA conform)
Dampening (option)	case fill	glycerin
	hydromechanical	



MAN-90/tc1"/.../gz



MAN-90/tc1"/.../h



MAN-90/gf40"/.../gz

Zero adjustment		±5%
Over-range capability		min. 25% of f. scale
Accuracy	repeatability	±0,5% of full scale
	linearity	±0,5% of full scale
	hysteresis	±0,5% of full scale
Temperature	process	-3°C...120°C
	CIP	120°C continuous
	SIP	149°C / 60min.
Temperature effect	ambient	-10°C...50°C**
	from 10-90% of range (process or ambient)	<±0,01%/K f.s.

**slower reaction at deep temperatures

Option MAN-90p (Pharma)

Surface roughness		Ra<0,2µm
Autoclaveable	yes (without case filling)	149°C / max. 60min.

*for temperatures up to 163°C

Accuracy	repeatability, linearity and hysteresis	each ±0,25% of f. s.
Adjustment	zero	±5%
	span (option)	±5%

Order Code

Type	Process connection	Range	Actuating fill	Dampening	Calibration	Connection
MAN-90	tc1" (TriClamp 1"/1,5")	-1...+2bar	paraffin oil* gc (neobee M20)	without* gz (glycerin filling) m (hydro-mechanical)	N (zero only)	u bottom* o top l left r right h back
	tc2" (TriClamp 2")	-1...+4bar				
	tc2,5" (TriClamp 2,5")	0...+2bar				
	tc3" (TriClamp 3")	0...+4bar				
	v40/50 (Varivent DN40/50)	0...+7bar				
	sm38(SMS male 38mm)	0...+11bar				
	sf38 (SMS female 38mm)	0...+20bar				
MAN-90p	sm51(SMS male 51mm)	0...+40bar	-1...+2bar		N (zero only)* V (zero and span)	
	sf51(SMS female 51mm)	0...+40bar				
	gm40 (DIN male DN40)	-1...+4bar				
	gf40 (DIN female DN40)	-1...+4bar				
	gm50 (DIN male DN50)	0...+2,5bar				
	gf50 (DIN female DN50)	0...+6bar				
idf38 (IDF 38mm)	0...+10bar	0...+16bar				
idf51 (IDF 51mm)	0...+40bar					

Order example: MAN-90 / tc2" / -1...+2bar / gc / gz / V

* standard, no declaration needed

Drawings MAN-90

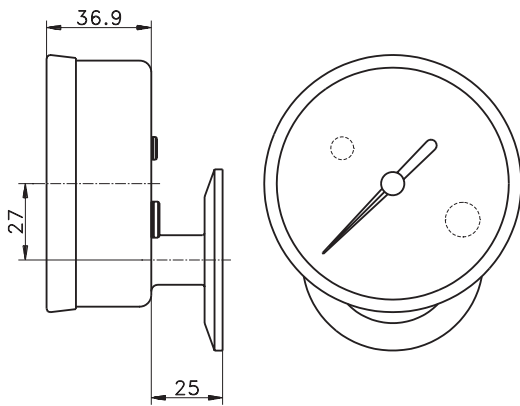



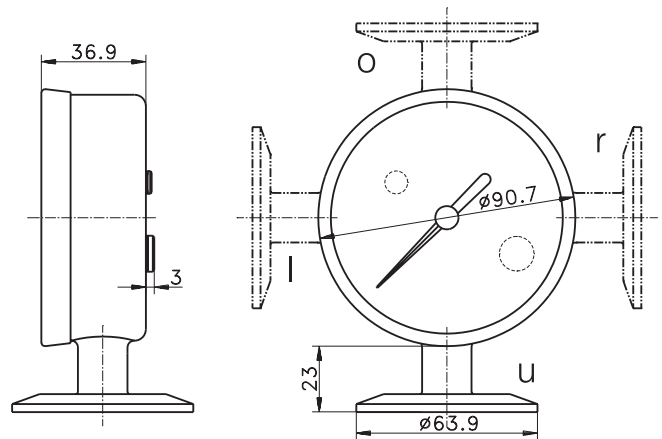





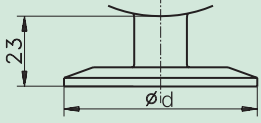

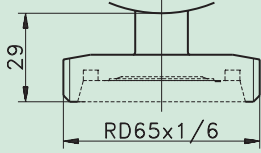
MAN-90 with connection "h" (back)

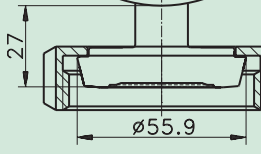

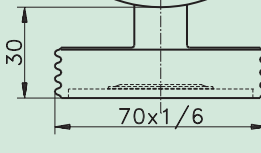
MAN-90 with connection "u" (bottom), "l" (left), "r" (right), "o" (top)

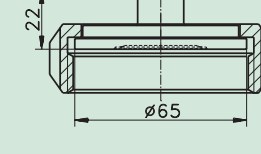
Overview of further process connection

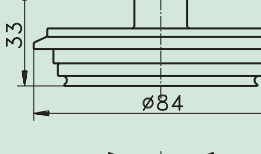
TriClamp	1" / 1,5" TriClamp d=50,5mm 2" TriClamp d=63,9mm 2,5" TriClamp d=77,5mm 3" TriClamp d=91,0mm * membrane diameter=33mm!	 
DIN11851 Male	DN40 DN50	 
DIN11851 Female	DN40 with nut DN50 with nut	 
SMS Male	SMS 38mm SMS 51mm	 
SMS Female	SMS 38mm with nut SMS 51mm with nut	 
Varivent	DN40/50	 
IDF	IDF 38mm IDF 51mm	