

1

2

3

4

A

A

B

B

C

C

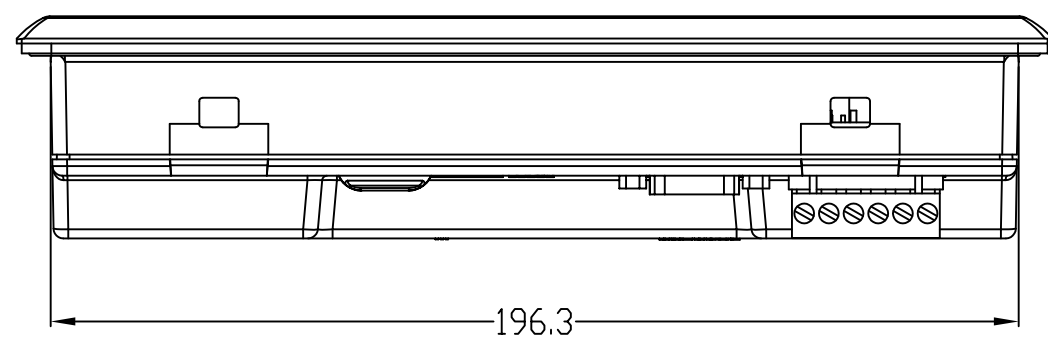
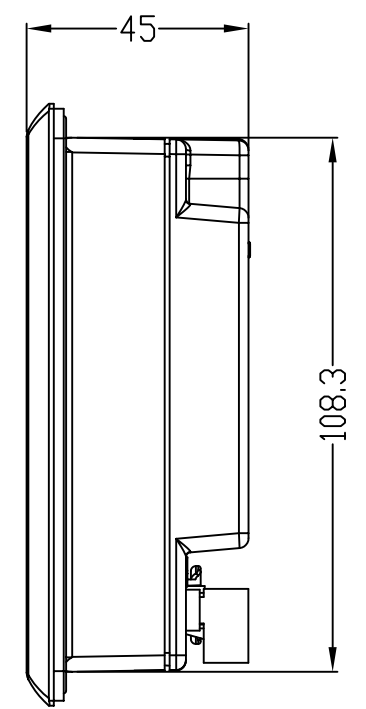
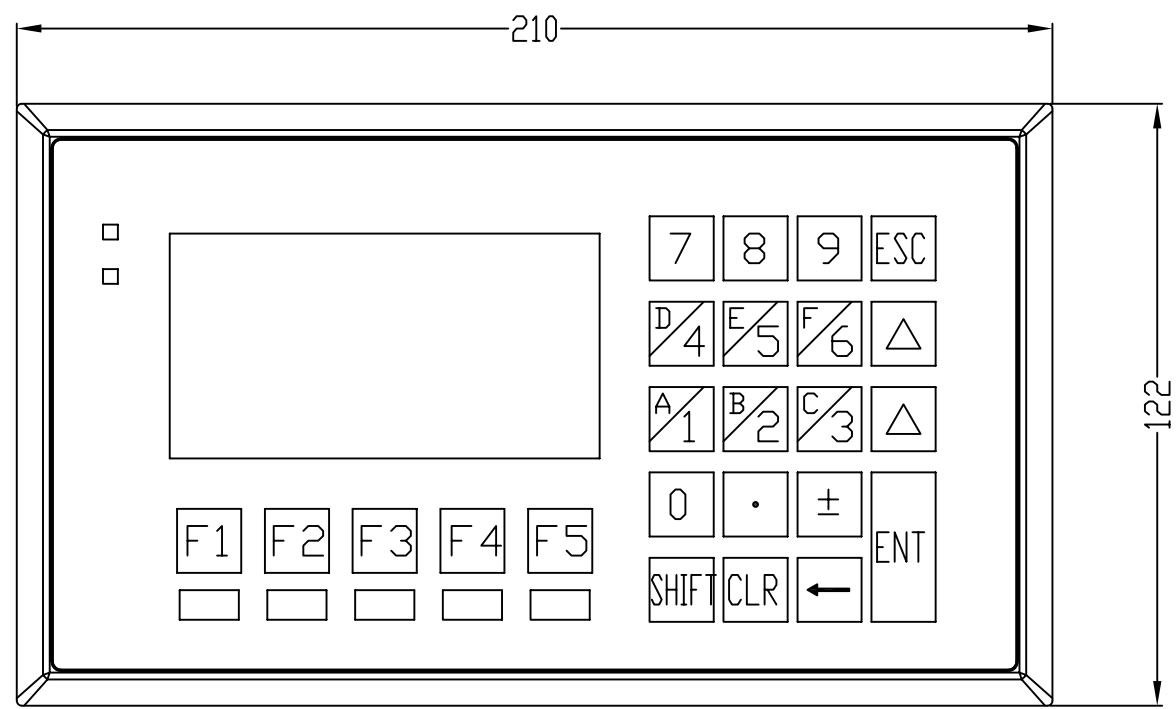
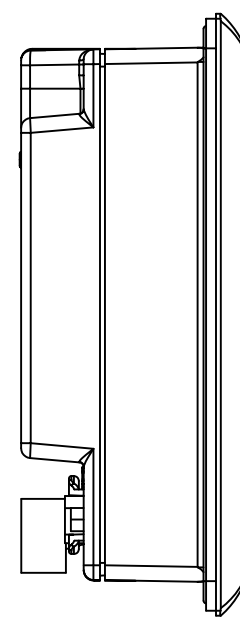
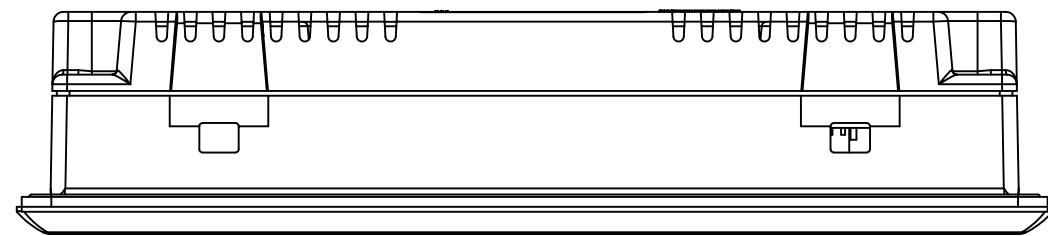

REV.	ECN NO.
00	-----

台達電子工業股份有限公司 DELTA ELECTRONICS, INC.		DRAWN:	DESIGN:
THESE DRAWINGS AND SPECIFICATIONS ARE THE PROPERTY OF DELTA ELECTRONICS, INC. AND SHALL NOT BE REPRODUCED OR USED AS THE BASIS FOR THE MANUFACTURE OR SELL OF APPARATUSES OR DEVICES WITHOUT PERMISSION.		DATE:	ECN NO.:
DRAWING NAME: TP05G-BT2, TP08G-BT2		DIMENSIONAL TOLERANCES ( ) ( ) ( ) ANGLES DECIMALS <50 ±0.1 <50 ±0.15 <50 ±0.2 <30° ±0.1° X ±0.3 >50-100 ±0.15 >50-100 ±0.2 >50-100 ±0.25 >30°-60° ±0.3° X.X ±0.2 >100-200 ±0.2 >100-200 ±0.25 >100-200 ±0.3 >60°-90° ±0.5° X.XX ±0.1 >200- ±0.2 >200- ±0.25 >200- ±0.3%	
USED ON	A3 SIZE 	PART NO.:	
UNIT mm	SCALE	SHEET 1 OF 1	

1

2

3

4