

**Inductive sensor  
With switching distance  
BI2-EG08-AP6X**

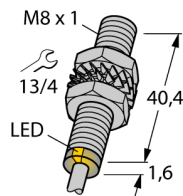

- Threaded barrel, M8 x 1
- Stainless steel, 1.4427 SO
- Large coverage
- DC 3-wire, 10...30 VDC
- NO contact, PNP output
- Cable connection

**Wiring diagram**

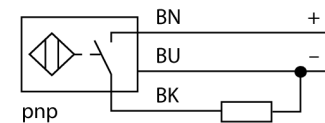

**Functional principle**

Inductive sensors detect metal objects contactless and wear-free. For this, they use a high-frequency electromagnetic AC field that interacts with the target. Inductive sensors generate this field via an RLC circuit with a ferrite coil.

<b>Type code</b>	BI2-EG08-AP6X
Ident no.	4602040
<b>Rated operating distance Sn</b>	2 mm
Mounting condition	flush
Assured switching distance	≤ (0,81 x Sn) mm
Repeatability	≤ 2 % of full scale
Temperature drift	≤ ± 10 %
Hysteresis	3...15 %
Ambient temperature	-25...+70 °C
<b>Operating voltage</b>	10...30VDC
Residual ripple	≤ 10 % U <sub>ss</sub>
DC rated operational current	≤ 150 mA
No-load current I <sub>0</sub>	≤ 15 mA
Residual current	≤ 0.1 mA
Rated insulation voltage	≤ 0.5 kV
Short-circuit protection	yes/ cyclic
Voltage drop at I <sub>0</sub>	≤ 1.8 V
Wire breakage / Reverse polarity protection	yes/ complete
Output function	3-wire, NO contact, PNP
Switching frequency	3 kHz
<b>Construction</b>	threaded barrel, M8 x 1
Dimensions	42 mm
Housing material	stainless steel, 1.4427 SO
Material active area	plastic, PA
End cap	Plastic, PA12-GF30
Max. tightening torque housing nut	5 Nm
Connection	cable
Cable quality	4 mm, LifYY-11Y, PUR, 2m
Cable cross section	3 x 0.25 mm <sup>2</sup>
Vibration resistance	55 Hz (1 mm)
Shock resistance	30 g (11 ms)
IP Rating	IP67
MTTF	2283 years acc. to SN 29500 (Ed. 99) 40 °C
<b>Switching state</b>	LED yellow

**Inductive sensor  
With switching distance  
BI2-EG08-AP6X**

Distance D	2 x B
Distance W	3 x Sn
Distance T	3 x B
Distance S	1.5 x B
Distance G	6 x Sn
<hr/>	
Diameter of the active area B	Ø 8 mm

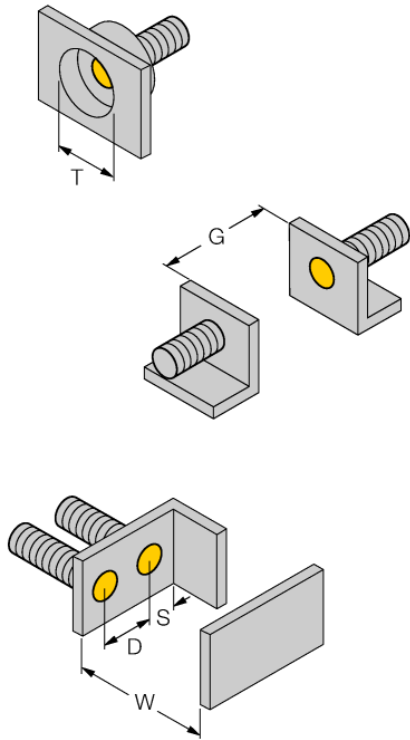

**Inductive sensor  
With switching distance  
BI2-EG08-AP6X**

**TURCK**

Industrial  
Automation

**Accessories**

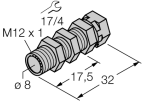
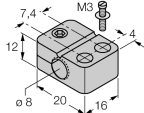
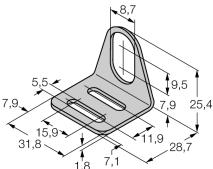
Type code	Ident no.	Description	Design
QM-08	6945100	Quick-mount bracket with dead-stop, chrome-plated brass, male thread M12 x 1. Note: The switching distance of proximity switches may be reduced through the use of quick-mount brackets.	
BST-08B	6947210	Fixing clamp for threaded barrel devices, with dead-stop; material: PA6	
MW-08	6945008	Mounting bracket for threaded barrel devices; material: Stainless steel A2 1.4301 (AISI 304)	
BSS-08	6901322	Mounting bracket for smooth and threaded barrel devices; material: Polypropylene	